



**AGENDA FOR THE REGULAR MEETING
OF THE MOORE CITY COUNCIL
MOORE PUBLIC WORKS AUTHORITY
THE MOORE RISK MANAGEMENT BOARD
AND THE MOORE ECONOMIC DEVELOPMENT AUTHORITY
DECEMBER 18, 2023 – 6:30 P.M.
CITY COUNCIL CHAMBERS
301 N. BROADWAY**

The City of Moore encourages participation from all its citizens. If participation at any public meeting is not possible due to a disability (such as a hearing or speech disability) notification to the City Clerk at least forty-eight (48) hours prior to the scheduled public meeting is encouraged to allow the City to make the necessary accommodations.

1) CALL TO ORDER

- A) Roll Call
- B) Pledge of Allegiance

2) CONSENT DOCKET:

- A) Receive and approve the minutes of the regular City Council meeting held December 4, 2023.
- B) Receive the minutes of the regular Parks Board meeting held November 7, 2023. **Page 8**
- C) Approve the issuance of a \$500 end-of-year stipend for all regular and probationary full-time active employees, as well as, all regular part-time active employees receiving benefits as of December 1, 2023; and a \$250 end-of-year stipend for all other active part-time employees as of December 1, 2023 per City Resolution No. 70(23).
- D) Appoint Emily Richey to the Moore Planning Commission to serve the remainder of a 3-year term beginning in August 2023.
- E) Approve and ratify claims and expenditures for FY 2023-2024 in the amount of \$5,799,475.73. **Page 14**

ACTION: _____

- 3) Consider approval of Ordinance No. 1038(23) amending Part 5, Chapter 1, Articles B, C and D by deleting Section 5-120 allowing for exceptions from building permit requirements, establishing investigation process and required fees for work done without a building permit and unauthorized cover-up work, and establishing a building board of appeals; providing for severability and providing for repealer. **Community Development Page 55**

ACTION: _____

- 4) Consider approval of Ordinance No. 1039(23) amending Part 5, Chapter 2, Article A, Sections 5-201 through 5-210 and Part 5, Chapter 2, Article D, Sections 5-251 through 5-253 adopting the 2018 International Building Code and the 2018 International Residential Code as amended and modified by the Oklahoma Uniform Building Commission and adopting local amendments to said code; establishing minimum regulations governing the design, installation and construction of buildings and for one-to-two family dwellings within the City; providing for severability and providing for repealer. **Community Development Page 62**

ACTION: _____

- 5) Consider approval of Ordinance No. 1040(23) amending Part 5, Chapter 3, Article A, Sections 5-301 through 5-307 adopting the 2018 International Plumbing Code as amended and modified by the Oklahoma Uniform Building Commission and adopting local amendments to said code; establishing minimum regulations governing the design, installation and construction of plumbing systems within the City; providing for severability and providing for repealer. **Community Development Page 85**

ACTION: _____

- 6) Consider approval of Ordinance No. 1041(23) amending Part 5, Chapter 4, Article A, Sections 5-401 and 5-411 adopting the 2020 National Electric Code as amended and modified by the Oklahoma Uniform Building Commission and adopting local amendments to said code; establishing minimum regulations governing the design, installation and construction of electrical systems within the City; providing for severability and providing for repealer. **Community Development Page 90**

ACTION: _____

- 7) Consider approval of Ordinance No. 1042(23) amending Part 5, Chapter 5, Article A, Sections 5-501 through 5-507 adopting the 2018 International Mechanical Code as amended and modified by the Oklahoma Uniform Building Commission and adopting local amendments to said code; establishing minimum regulations governing the design, installation and construction of mechanical systems within the City; providing for severability and providing for repealer. **Community Development Page 96**

ACTION: _____

- 8) Consider approval of Ordinance No. 1045(23) amending Part 5, Chapter 9, Sections 5-901 through 5-902 adopting the 2018 International Fuel Gas Code as amended and modified by the Oklahoma Uniform Building Commission and adopting local amendments to said code; establishing minimum regulations governing the design, installation and construction of fuel gas systems within the City; providing for severability and providing for repealer. **Community Development Page 99**

ACTION: _____

- 9) Consider approval of Ordinance No. 1046(23) amending Part 5, Chapter 12, Sections 5-1201 through 5-1202 adopting the 2018 International Existing Building Code as amended and modified by the Oklahoma Uniform Building Commission and adopting local amendments to said code; establishing minimum regulations governing the design, modification and remodeling of existing buildings within the City; providing for severability and providing for repealer. **Community Development Page 103**

ACTION: _____

- 10) Consider approval of Ordinance No. 1043(23) amending Part 8, Chapter 11, Article A, Section 8-1105 and Article B, Sections 8-1111 through 8-1114 adopting the 2018 International Property Maintenance Code and adopting local amendments to said code; establishing minimum regulations governing the enforcement, evaluation, procedure and construction of property maintenance within the City; providing for severability and providing for repealer. **Community Development Page 107**

ACTION: _____

- 11) Consider approval of Ordinance No. 1044(23) amending Part 13, Chapter 1, Article A, Section 13-101 and 13-103 adopting the 2018 International Fire Code as amended and modified by the Oklahoma Uniform Building Code Commission and adopting local amendments to said Code; establishing minimum regulations governing the installation and construction of building fire protection within the City; providing for severability and providing for repealer. **Community Development Page 118**

ACTION: _____

- 12) Consider awarding Bid No. 2024-006 "Veterans Memorial Park Trail Enhancement" to Greenshade Trees, LLC in the amount of \$562,209.85 as the lowest bidder; and approve contract for same. **Parks and Recreation Page 128**

ACTION: _____

- 13) Consider authorizing staff to solicit proposals for the management and programming of recreational youth baseball activities to be held at Buck Thomas Park for the 2024 league and tournament season. **Parks and Recreation Page 137**

ACTION: _____

- 14) Consider approval of a budget amendment to provide for purchase of property at 2001 N. Moore (purchase authorized by Council on September 18, 2023), increase budget for additional grants and donations received during FY 2024, carryover balance of prior year equipment per Fire union contract, and increase softball improvements budget to utilize prior year collections. **Finance Page 146**

ACTION: _____

- 15) Consider approval of an Agreement with TEIM Design, PLLC in the amount of \$244,240 for professional engineering services for the N.W. 27th Street Reconstruction Project from Hillcrest Avenue extending east to the I-35 Service Road. **Management Page 147**

ACTION: _____

- 16) Consider approval of an Agreement with Garver, LLC in the amount of \$453,924 for professional engineering services for the Eastern Avenue Reconstruction Project from NE 12th Street to NE 27th Street. **Management Page 173**

ACTION: _____

- 17) Consider approval of an Agreement with Olsson Inc. in the amount of \$550,825 for professional engineering services for the N.E. 27th Street Reconstruction Project from Eastern Avenue extending west to the I-35 Service Road. **Management Page 194**

ACTION: _____

- 18) Consider awarding a contract in the amount of \$83,549.85 with John A. Marshall Company, utilizing OMNIA Partners, a government purchasing co-op, for furniture for the new Moore Animal Adoption Center. **Management Page 223**

ACTION: _____

- 19) Consider approval of a renewal Application for Stop-Loss Insurance with Ironshore Indemnity Inc., to be administered by Assured Benefits Administrators, Inc., effective January 1, 2024 through January 1, 2025. **Human Resources Pg 233**

ACTION: _____

RECESS THE CITY COUNCIL MEETING AND CONVENE THE MOORE PUBLIC WORKS AUTHORITY MEETING.

20) CONSENT DOCKET:

- A) Receive and approve the minutes of the regular Moore Public Works Authority meeting held December 4, 2023.
- B) Ratify action of the City Council regarding renewal application for Stop-Loss Insurance with Ironshore Indemnity, Inc. to be administered by Assured Benefits Administrators, Inc., effective January 1, 2024 through January 1, 2025.
- C) Approve and ratify claims and expenditures for FY 2023-2024 in the amount of \$715,803.71. **Page 236**

ACTION: _____

- 21) Consider approval of an Excess Public Officials and Employment Practices Liability policy with Indian Harbor Insurance Company in the amount of \$49,580.44 with Glenn Harris and Associates as agent. **Risk Management Page 242**

ACTION: _____

- 22) Consider approval of a Property and Contents insurance policy through OMAG, Excess Property and Contents policy through Homeland Insurance Company of New York, Excess Flood insurance policy through Voyager Indemnity Insurance Company, Cyber insurance through Underwriters at Lloyd's, and Physical Damage coverage for the City's sanitation trucks, fire trucks, and mobile command unit, through RLI, with a total premium amount for all policies in the amount of \$851,417.02 with Russell Hollingsworth of Dillingham Insurance as agent. **Risk Management Page 248**

ACTION: _____

RECESS THE MOORE PUBLIC WORKS AUTHORITY MEETING AND CONVENE THE MOORE RISK MANAGEMENT MEETING:

23) CONSENT DOCKET:

- A) Receive and approve the minutes of the regular Moore Risk Management meeting held December 4, 2023
- B) Approve payment of a worker's compensation settlement in the amount of \$20,736 for CBR No. 2050001032 to Joshua Trent; and authorize placement on the ad valorem tax roll.

- C) Approve payment of a worker's compensation settlement in the amount of \$15,840 for CBR No. 2050001103 to Ernest Lockett; and authorize placement on the ad valorem tax roll.
- D) Approve and ratify claims and expenditures for FY 2023-2024 in the amount of \$312,627.20. **Page 249**

ACTION: _____

RECESS THE MOORE RISK MANAGEMENT MEETING AND CONVENE THE MOORE ECONOMIC DEVELOPMENT AUTHORITY MEETING:

24) ROLL CALL

25) CONSENT DOCKET:

- A) Receive and approve the minutes of the regular Moore Economic Development Authority meeting held November 20, 2023. **Page 291**

ACTION: _____

RECESS THE MOORE ECONOMIC DEVELOPMENT AUTHORITY MEETING AND RECONVENE THE CITY COUNCIL MEETING:

26) NEW BUSINESS:

- A) Citizens' forum for items not on the agenda.
- B) Items from the City Council/Trustees.
- C) Items from the City/Trust Manager.

27) EXECUTIVE SESSION:

Section 307, Title 25, Oklahoma Statutes permits the public body to meet in executive session for certain specified reasons under certain specified conditions. It is the opinion of the City Attorney that the City Council may consider and adopt a motion to meet in executive session to discuss the following item(s):

- A) Discuss, consider, and if deemed appropriate, take possible action in pending litigation styled Jeff Cloud PLLC v. City of Moore, Case No. CJ-2023-1481; and authorization for legal counsel and staff to take action as necessary and appropriate in the interest of the City, as authorized by 25 Okla. Stat. § 307(B)(4).

**MINUTES OF A REGULAR MEETING
OF THE CITY OF MOORE PARKS BOARD
November 7th, 2023 -6:00 PM**

The Parks Board of the City of Moore met in regular session, 301 N Broadway, Moore, Oklahoma on November 7th, 2023 at 6:00 p.m. with Chairman Sid Porter presiding. The following members were present:

Charles Payne	Sid Porter
Janie Milum	Kelley Mattocks
Eddie Vickers	

ABSENT: Robert Washington

STAFF MEMBERS PRESENT: Parks and Recreation Director, Sue Wood; and Administrative Assistant, Rita Chadrick.

Agenda Item Number 1 being:

- ROLL CALL; (listed above).

Agenda Item Number 2 being:

RECEIVE AND APPROVE THE MINUTES FROM THE REGULAR MEETING HELD OCTOBER 3rd, 2023

Vice Chairman Payne motioned to approve the minutes from the regular meeting held October 3rd, 2023; second by Secretary Mattocks. Motion passed unanimously.

Ayes: Payne, Porter, Milum, Mattocks, Vickers

Nays: None

Absent: Washington

Agenda Item Number 3 being:

MOORE YOUTH BASEBALL ANNUAL REPORT

President of the Moore Youth Baseball Association, Lindsay Purser, reported that the spring league, from March through June, had a total of 1,031 kids, split into nine age divisions, for a total of 76 teams. Had 12 tournaments; four cancelled due to weather. Fall league, from August through October, had 673 kids split into nine age divisions for a total of 48 teams. Had nine tournaments; one cancelled.

MYBA took over Courage League this year, an all-abilities league for the surrounding metro area. Had six teams in the spring with a total of 89 and seven teams in the fall with 92 participants ranging in age from 4-38 years old. Games were held on Tuesday nights on adaptive 10U-11U fields; volunteers help the players. MYBA also purchased a new mower and hired a new groundskeeper; they're also in the process of purchasing a new drag for the spring 2024 season.

Chairman Porter commented that it was a good year for them financially and they have a good start for next season with \$20,000; he also asked if they have an auditor that does their reports.

Lindsay responded that they have an accountant, Jerry Saxon, that she sends reports to every Monday morning. They weren't able to have October's numbers in the report due to the season just finishing but will get it to Sue to pass on to the Board.

Board Member Milum asked why MYBA has not filed an IRS 990 since 2020 and if they are submitting the required monthly reports to the Parks Department. Lindsay responded that she will get back to Board Member Milum on the IRS 990 as she is not sure about it due to just taking over as president of MYBA; she also said that she didn't know she was supposed to be submitting monthly reports to the Parks Department. Board Member Milum responded that under "Bookkeeping" in the agreement with the City that Lindsay signed it states what MYBA is supposed to be doing as far as reports are concerned and she assumed that Lindsay would know that.

Chairman Porter asked if the board needs to do anything about the missing IRS reports and the monthly reports.

Parks and Recreation Director, Sue Wood, responded that MYBA should be working on getting those documents now and submitting them to her.

Lindsay added that the transition to president has been kind of crazy; her mother-in-law passed away right after they took over and trying to figure everything out has been a sticky situation but she'll make sure that all documents are submitted.

Matt Purser, Tournament Director for MYBA, stated that part of the problem is that the lease agreement is signed by the former president and when board members change not all information gets relayed from president to president. Another problem is finding people that want to get involved and be involved for the right reasons; it always seems like the next person that takes over is always pushing the other people out because they didn't like what was done previously.

Vice Chairman Payne asked if their accountant takes care of filing paperwork to the IRS and asked what UIC fees are. He also asked about the Treasurer's Fee on the report since

they are paying an accountant. Board Member Vickers asked about the \$12,800 City lease fee and the \$4,042.89 rent or lease fees on the report. Secretary Mattocks asked if the MYBA board is all-volunteer as she noticed on the report that the previous president was paid \$2,000.

Lindsay responded that UIC fees are Umpire in Charge fees but the amount on the report is incorrect as they combined Umpire in Charge fees and regular umpire fees into one instead of separating them. She explained that they used to have a treasurer who was paid, but when things changed she went away so they don't have a treasurer anymore. She stated that she is unsure of what the \$4,042.89 rent or lease fees are; the \$12,800 City lease fee is payment for both 2022 and 2023 since they did not pay the fee in 2022. She added that the board had agreed to pay the previous president \$500 per month but noted that she herself did not receive that pay when she became president.

Board Member Vickers asked if participants in their league can attend MYBA board meetings and call for a vote; for example, if someone does something incorrectly and noted that people have said they don't know when the meetings are held. He added that when he was president of MYBA they would train the vice president to be the next president so there is continuity, but it seems like MYBA now doesn't do a good job of this.

Lindsay responded that meetings are listed on their website and as long as they're in good standing with the league she doesn't see why they couldn't call for a vote if needed. She added that her hope is to train someone to be the next president once they figure things out.

Chairman Porter stated that the agreements for every sports association should be checked to make sure all associations are in compliance with their agreements. He asked when the new contract is due to be signed and whether a vote was needed at this time and thanked Lindsay for her report.

Sue responded that the contract would be signed in February and a vote is not needed at this time.

Agenda Item Number 4 being:

UPDATING PARKS BOARD DUTIES AND RESPONSIBILITIES

Sue stated that with Jeff Arvin's resignation creating a vacancy on the board she noticed that there is no set standard as to how a new Parks Board member is appointed. Some questions she had include: Should there be an interview process for the board; if there is an interview process which member should be on the interview committee; should the preferred candidate then be interviewed by the City Council; after the interview process is completed by the City Council should the candidate then be appointed by the City

Council. She added that it was suggested to have a representative from the Brand Senior Center as a member of the Parks Board since the Council on Aging no longer meets at the center; however, there are questions that need to be asked and if there is a “Senior” Park Board member what would the process be for choosing that member. She stated that the City Manager suggested the Parks Board develop a committee to determine the answers to these questions and discuss ways of possibly doing this.

Board Member Vickers suggested the seniors from the Brand Senior Center form another group and have a representative from that group come and discuss anything with the Parks Board as other organizations do.

Board Member Milum stated that there is no consistency as to how a person is appointed to the Parks Board; when she applied to serve on the board she had to make a presentation in front of the City Council as did Secretary Mattocks. Board Member Vickers stated that he was approached to be on the board because he was a part of MYBA at the time and would be able to continue to help kids as a member of the Parks Board.

Chairman Porter asked if the City Council appoints new members to all of the boards or just the Parks Board and suggested meeting with the City Manager to discuss a consistent way to appoint someone to the board instead of it just being political or requiring a person from a specific ward.

Sue responded that the City Council developed an interview committee for the Planning Commission board and suggested the Parks Board interview applicants for its vacant position then recommend whomever they select to the City Council’s interview committee. She added that the vacancy for Jeff Arvin’s position was posted for more than eight weeks but only one person applied; she suggested tabling this and having a discussion with the City Manager for more guidance.

Vice Chairman Payne asked if each City Council member is attached to a specific board and if that Council member sits in on that board’s meeting. Chairman Porter responded that it was that way when Parks Board first started.

Board Member Vickers noted that by 2027 all of the existing Parks Board members will have been or will be replaced due to new term limits and the City Council needs to look at that as people aren’t beating down doors to apply for the Parks Board.

Vice Chairman Payne motioned to table the updating of Park Board responsibilities; second by Board Member Milum.

Ayes: Payne, Porter, Milum, Mattocks, Vickers
Nays: None
Absent: Washington

Agenda Item Number 5 being:

NEW BUSINESS:

(A) CITIZENS TO BE HEARD

There were no citizens present to be heard.

(B) ITEMS FROM THE PARK BOARD

Board Member Milum stated that the Aging Services Chili Cook-off was a huge success and more than \$1,500 was made between chili sales and the silent auction. She thanked the Parks Department for their help in setting up the venue, the wrestlers from Moore High School who helped during the event, and everyone who participated and added that it was pretty competitive and they are already working on planning next year's event.

Secretary Mattocks spoke about concerns she had regarding complaints on Facebook about Moore Youth Football tournaments being held recently in inclement weather; she noted that some of the feedback came from members of their own organization and their board.

Sue responded that it was very cold and rainy the weekend the tournaments were held but the association's new president said it would've been difficult to cancel since it was for breast cancer awareness and there were many teams that came from all over to play; coaches had also let their teams know prior to the tournament that there could be a possibility of bad weather. Sue stated she talked to the president about the complaints and in the future he will cancel tournaments when the weather is that cold.

Agenda Item Number 6 being:

REPORTS

Sue reported that 300 people attended the Halloween Dance at MCC on Oct. 27; she also drove the Parks Department's new train during the Red Ribbon Parade the next day. Kasey Dean, Special Events Coordinator, is putting up holiday decorations at the Station and working on the Christmas Spectacular scheduled for December 1.

Vice Chairman Payne asked what the plans are as far as using the new train. Secretary Mattocks asked when the light show outside the Station will start and if there would be fireworks at the Christmas Spectacular this year.

Sue responded that the train will be used at special events like the Fourth of July. The light show will start the day after Thanksgiving and there will be fireworks at the Christmas Spectacular this year; it was cancelled last year due to an accident.

Agenda Item Number 6-1 being:

ELECTIONS

Board Member Milum motioned to keep current officers as is with Sid Porter as Chairman, Charles Payne as Vice Chairman, and Kelley Mattocks as Secretary; second by Vice Chairman Payne.

Ayes: Payne, Mattocks, Porter, Milum, Vickers
Nays: None
Absent: Washington

Agenda Item Number 7 being:

ADJOURNMENT

Board Member Milum motioned to adjourn the regular meeting of the Moore Parks Board; second by Board Member Vickers. Motion passed unanimously.

Ayes: Payne, Mattocks, Porter, Milum, Vickers
Nays: None
Absent: Washington

The Moore Parks Board meeting adjourned at 6:51 p.m.

RECORDED/TRANSCRIBED BY:



RITA CHADRICK, Parks and Recreation Administrative Assistant

FOR:



KELLEY MATTOCKS, Secretary

These minutes passed and approved as noted this 5th day of December, 2023.

**CLAIMS FOR APPROVAL
FISCAL YEAR 2023-2024
COUNCIL MEETING DECEMBER 18, 2023**

CITY OF MOORE

Payroll of November 19, 2023 to December 02, 2023		\$	1,217,702.61
Payroll Related Claims		\$	403,471.21
GO Street Bonds 2010 (Ratification 11-30-23)	(04)	\$	887,063.59
GO Street Bonds 2010 (Ratification 12-07-23)		\$	282,909.81
General Fund (Ratification 11-30-23)	(06)	\$	165,751.03
General Fund (Ratification 12-01-23)		\$	30,000.00
General Fund (Ratification 12-07-23)		\$	277,599.75
Special Revenue Fund (Ratification 11-30-23)	(08)	\$	30,640.48
Special Revenue Fund (Ratification 12-07-23)		\$	8,118.26
Debt Service Fund (Ratification 12-07-23)	(09)	\$	1,893,256.25
Urban Renewal Authority (Ratification 11-30-23)	(10)	\$	24,849.13
Stormwater Systems (Ratification 12-07-23)	(11)	\$	40,424.12
Public Safety/Streets Sales Tax (Ratification 11-30-23)	(12)	\$	5,624.55
Public Safety/Streets Sales Tax (Ratification 12-07-23)		\$	3,319.65
Parks Sales Tax (Ratification 12-07-23)	(13)	\$	528,745.29
	Fund Total	\$	<u>5,799,475.73</u>

MOORE PUBLIC WORKS AUTHORITY

Moore Risk Management (Ratification 11-30-23)	(02)	\$	5,804.37
Moore Risk Management (Ratification 12-07-23)		\$	7,515.58
Moore Public Works (Ratification 11-30-23)	(05)	\$	401,229.48
Moore Public Works (Ratification 12-07-23)		\$	301,254.28
	Fund Total	\$	<u>715,803.71</u>

ALL FUNDS GRAND TOTAL	\$	<u><u>6,515,279.44</u></u>
------------------------------	-----------	-----------------------------------

**CLAIMS FOR RATIFICATION
Fiscal Year 2023-2024
DISTRIBUTION NOVEMBER 30, 2023
COUNCIL MEETING DECEMBER 18, 2023**

CITY OF MOORE

GO Street Bonds	(04)	\$	887,063.59
General Fund	(06)	\$	165,751.03
Special Revenue Fund	(08)	\$	30,640.48
Urban Renewal Authority	(10)	\$	24,849.13
Public Safety/Streets Sales Tax	(12)	\$	5,624.55
	Fund Total	\$	<u>1,113,928.78</u>

MOORE PUBLIC WORKS AUTHORITY

Moore Risk Management	(02)	\$	5,804.37
Moore Public Works	(05)	\$	401,229.48
	Fund Total	\$	<u>407,033.85</u>

ALL FUNDS GRAND TOTAL **\$ 1,520,962.63**

CLAIMS FOR RATIFICATION

MOORE CITY COUNCIL

COUNCIL MEETING DECEMBER 18, 2023

Moore City Council
General Fund 2023-2024
Vendor & Employee Claims

Moore, OK Purchase Order Claim Register



Fund: 04 - Street Bond Improvements

Check Run : 113023

Department: 531 - 2019 GO Street/Drainage

P.O. #	Vendor #	Name	Summary Description	Date	Invoice	Amount
194709	1593	POE & ASSOCIATES, INC	BNSF 4TH ST UNDERPASS	11/7/2023	100855	10,656.00
		04035310 - 54315 - 12001	Engineering			

Department Total : 10,656.00

Department: 533 - 2021 GO Street/Drainage

P.O. #	Vendor #	Name	Summary Description	Date	Invoice	Amount
231327	3770	ALLEN CONTRACTING, INC.	EASTERN AVE WIDENING SE19TH-SE4TH ST	10/31/2023	100857	406,935.85
		04035330 - 54300 - 12005	Construction			
221498	1638	PINNACLE CONSULTING MANAGEMENT GROUP, INC	PROFESSIONAL SERVS- EASTERN AVE SE 4TH TO SE 19TH	9/21/2023	100960	2,200.00
		04035330 - 54320 - 12005	Land			

Department Total : 409,135.85

Department: 535 - 2022B GO Streets/Animal Sh

P.O. #	Vendor #	Name	Summary Description	Date	Invoice	Amount
223608	3403	CROSSLAND CONSTRUCTION COMPANY INC	CONSTRUCTION MGMT @ RISK CONTRACT	10/30/2023	100853	467,271.74
		04035350 - 54300 - 12018	Construction			

Department Total : 467,271.74

Fund Total : 887,063.59

Moore, OK Purchase Order Claim Register



Fund: 06 - General Fund

Check Run : 113023

Department: 000 - Undesignated

P.O. #	Vendor #	Name	Summary Description	Date	Invoice	Amount
241847	1208	NETWORK SERVICES COMPANY	FAC custodial inventory restock	11/6/2023	100308	2,774.44
		6 - 12051 -	Inventory Building Maintenance			
	1	ONE TIME PAY VENDOR	BONDREF 231704375 L.SCOTT	11/8/2023	100475	222.50
		6 - 21030 -	Refunds Payable			
	1	ONE TIME PAY VENDOR	BondRef 231702536 H.Mcnabb	11/11/2023	100478	362.00
		6 - 21030 -	Refunds Payable			
	1	ONE TIME PAY VENDOR	BondRef 231701383 B.Dobbs	11/10/2023	100481	70.00
		6 - 21030 -	Refunds Payable			
	1	ONE TIME PAY VENDOR	2BondRef 231704008/231704009 T.Tipton	11/9/2023	100482	102.00
		6 - 21030 -	Refunds Payable			
Department Total :						3,530.94

Department: 035 - General Government

P.O. #	Vendor #	Name	Summary Description	Date	Invoice	Amount
240083	811	FARMERS BROTHERS COFFEE	COFFEE FOR PD AND CITY HALL	11/7/2023	100254	191.02
		06010350 - 51040 -	Coffee Supples			
240451	103	OKLAHOMA GAS & ELECTRIC	ELECTRICITY	11/16/2023	100666	116.79
		06010350 - 52100 -	Electricity			
240374	3706	PIERCE COUCH HENDRICKSON BAYSINGER & GREEN, LLP	LEGAL SERVICES	11/8/2023	100668	180.00
		06010350 - 52370 - 15420	Legal Expense			
240200	1727	OKLAHOMA NATURAL GAS	NATURAL GAS, COMBINED	11/21/2023	100836	612.33
		06010350 - 52105 -	Natural Gas			
242210	92	NORMAN TRANSCRIPT	23 (23) , 22 (23), 21 (23) publication ORD#	11/10/2023	100914	11.25
		06010350 - 52000 -	Printing & Publications			
242210	92	NORMAN TRANSCRIPT	23 (23) , 22 (23), 21 (23) publication ORD#	11/10/2023	100915	11.70
		06010350 - 52000 -	Printing & Publications			
242210	92	NORMAN TRANSCRIPT	23 (23) , 22 (23), 21 (23) publication ORD#	11/10/2023	100916	12.60
		06010350 - 52000 -	Printing & Publications			
Department Total :						1,135.69

Department: 043 - Finance

P.O. #	Vendor #	Name	Summary Description	Date	Invoice	Amount
242027	2748	SUNDANCE OFFICE SUPPLY, INC.	TONERS FOR CUST SERV	11/9/2023	100609	143.54
		06010430 - 51000 -	General Office Supplies			
242195	3868	JOHN PARKER	Reimb. 23-24 CPE/OK Ethics & Conduct for CPAs	11/22/2023	100804	237.95
		06010430 - 52005 -	Dues, Mbrshps, Mtgs & Training			
Department Total :						381.49

Department: 044 - Information Technology

P.O. #	Vendor #	Name	Summary Description	Date	Invoice	Amount
240671	944	CELLCO PARTNERSHIP	Verizon bill for July-December 2023	11/15/2023	100733	12,952.98

Moore, OK Purchase Order Claim Register



Fund: 06 - General Fund

Check Run : 113023

Department: 044 - Information Technology

P.O. #	Vendor #	Name	Summary Description	Date	Invoice	Amount
		06010440 - 52130 -	Wireless Tech Licenses			
242176	944	CELLCO PARTNERSHIP	Ipads for Santiation	11/15/2023	100746	7,745.90
		06010440 - 51150 -	Minor Equipment			
240202	730	COX COMMUNICATIONS, INC	UNDERCOVER INTERNET	11/15/2023	100904	74.95
		06010440 - 52135 -	Internet Expense			
Department Total :						20,773.83

Department: 050 - Municipal Court

P.O. #	Vendor #	Name	Summary Description	Date	Invoice	Amount
242021	3031	INFORMATION AND TRAINING INTERNATIONAL LLC	Spanish Interpreter for Court	11/7/2023	100319	141.22
		06020500 - 52360 -	Professional Services			
242096	3031	INFORMATION AND TRAINING INTERNATIONAL LLC	Spanish Interpreter for Court	11/9/2023	100557	141.22
		06020500 - 52360 -	Professional Services			
241000	3065	QUADIENT, INC.	Meter Rental in Courts	11/8/2023	100621	137.70
		06020500 - 52200 -	Equipment Rental			
242228	834	DOTMAN GRAPHIC DESIGN INC	Website Development	11/27/2023	100948	750.00
		06020500 - 52360 -	Professional Services			
Department Total :						1,170.14

Department: 051 - Police

P.O. #	Vendor #	Name	Summary Description	Date	Invoice	Amount
242121	448	SPECIAL OPS UNIFORMS	2 velcro name plates M/C jackets Shahan/Montague	11/27/2023	100858	40.00
		06020510 - 51225 -	Uniform Acquisition/Rental			
242122	448	SPECIAL OPS UNIFORMS	Tania Woods windbreaker	11/27/2023	100860	79.99
		06020510 - 51225 -	Uniform Acquisition/Rental			
241677	448	SPECIAL OPS UNIFORMS	2 shirt/2 pants Robinson, 2 shirts/2 pants Yost	11/27/2023	100862	335.96
		06020510 - 51225 -	Uniform Acquisition/Rental			
242075	448	SPECIAL OPS UNIFORMS	Landrum, Brown, Kevin Pitts, Barnes	11/21/2023	100863	503.94
		06020510 - 51225 -	Uniform Acquisition/Rental			
242075	448	SPECIAL OPS UNIFORMS	Landrum, Brown, Kevin Pitts, Barnes	11/21/2023	100864	187.49
		06020510 - 51225 -	Uniform Acquisition/Rental			
242173	3164	AMAZON.COM SALES, INC.	Armory supplies	11/24/2023	100907	108.70
		06020510 - 51025 -	Armory Supplies			
234705	56	GALL'S, INC.	43 gold hat band, 43 navy air force cap, 43 hat ba	11/6/2023	100909	3,784.00
		06020510 - 51150 -	Minor Equipment			
242203	2526	SEACA SYSTEMA COMBATIVES	Sniper/public venue trns OUPD Melton/Montague	11/20/2023	100923	3,200.00
		06020510 - 52755 -	Emergency Response Team			
Department Total :						8,240.08

Moore, OK Purchase Order Claim Register



Fund: 06 - General Fund

Check Run : 113023

Department: 052 - Communications/Dispatch

P.O. #	Vendor #	Name	Summary Description	Date	Invoice	Amount
241676	74	MATTOCKS PRINTING CO. LLC	Locker name plates Penner & McLemore	11/20/2023	100808	17.00
		06020520 - 51000 -	General Office Supplies			
242168	38	DEPT OF PUBLIC SAFETY	OLETS bill October 2023 INVOICE LET-012490	11/20/2023	100809	1,720.00
		06020520 - 52205 -	Other Rentals & Fees			
Department Total :						1,737.00

Department: 054 - Fire

P.O. #	Vendor #	Name	Summary Description	Date	Invoice	Amount
240393	48	OKLAHOMA STATE UNIVERSITY	EMR Class French & Fields (Recruits 23-1)	10/11/2023	100237	400.00
		06020540 - 52006 -	Training			
241819	3729	BPB HOLDING CORP	Battery Packs for Suction Units	11/8/2023	100335	151.96
		06020540 - 51060 -	Medical Supplies			
242033	2748	SUNDANCE OFFICE SUPPLY, INC.	Office Supplies MFD (Sundance)	11/7/2023	100377	857.05
		06020540 - 51000 -	General Office Supplies			
240446	2748	SUNDANCE OFFICE SUPPLY, INC.	Office Supplies for MFD (Sundance)	11/7/2023	100378	160.46
		06020540 - 51000 -	General Office Supplies			
240446	2748	SUNDANCE OFFICE SUPPLY, INC.	Office Supplies for MFD (Sundance)	11/8/2023	100379	105.02
		06020540 - 51000 -	General Office Supplies			
241926	68	JEM GLASS & SERVICE COMPA	Glass Repair @ Station #3	11/7/2023	100600	269.42
		06020540 - 52260 -	Building Maintenance/Repair			
240884	3880	CONWAY SHIELD, INC	Promotional Helmet Front (Lujan)	11/16/2023	100601	127.30
		06020540 - 51160 -	Minor Safety Equipment			
242131	2803	MAYA 4818 LLC	Shipment of Statpaks for Warranty Repair	11/6/2023	100643	60.91
		06020540 - 51250 -	Misc. Materials & Supplies			
240451	103	OKLAHOMA GAS & ELECTRIC	ELECTRICITY	11/16/2023	100666	453.35
		06020540 - 52100 -	Electricity			
241422	823	CHEROKEE NATION ENTERPRISES	Hotel Room for IAAI Conference	10/24/2023	100755	362.52
		06020540 - 52006 -	Training			
241715	11	AMERICAN LOGO & SIGN INC.	Helmet Lettering for MFD	10/12/2023	100758	26.00
		06020540 - 51160 -	Minor Safety Equipment			
240857	26	CHIEF FIRE & SAFETY, INC	Eagle and Helmet Parts	9/28/2023	100765	240.00
		06020540 - 51160 -	Minor Safety Equipment			
242044	863	STOLZ TELECOM LLC	Install of Harris Radio on E-1	11/9/2023	100767	170.00
		06020540 - 51070 -	Parts			
240452	103	OKLAHOMA GAS & ELECTRIC	ELECTRICITY COMBINED	11/17/2023	100835	29.63
		06020540 - 52100 -	Electricity			
Department Total :						3,413.62

Moore, OK Purchase Order Claim Register



Fund: 06 - General Fund

Check Run : 113023

Department: 064 - Public Works

P.O. #	Vendor #	Name	Summary Description	Date	Invoice	Amount
241941	2923	WARREN PRODUCTS, INC.	CALENDARS FOR 2024-PUBLIC WORKS	11/6/2023	100233	258.19
		06040640 - 51000 -	General Office Supplies			
241665	3863	A & A LAWN CARE SERVICE LLC	TEMP WORK FOR CITY OF MOORE STREET DEPARTMENT	11/6/2023	100281	3,000.00
		06040640 - 52350 -	Temporary Labor			
241861	2570	BOOT BARN	Coveralls & jacket for Michael Brooks	11/7/2023	100290	215.98
		06040640 - 52355 -	Contract Services			
241860	2570	BOOT BARN	Coveralls & jacket for Robert Mckinley	11/7/2023	100295	251.98
		06040640 - 52355 -	Contract Services			
241858	2570	BOOT BARN	Coveralls & jacket for Karl Stevenson II	11/7/2023	100296	260.98
		06040640 - 52355 -	Contract Services			
240586	154	TRAFFIC SIGNALS INC.	TRAFFIC SIGNAL/SCHOOL ZONE LIGHT REPAIRS ET	11/6/2023	100299	870.00
		06040640 - 52354 -	Outsource Labor			
241506	189	O'REILLY AUTOMOTIVE INC	SUPPLIES FOR STREET DEPARTMENT EQUIPMENT ETC	11/7/2023	100301	130.94
		06040640 - 51105 -	Street Materials			
240099	1313	CENTRAL OKLAHOMA HOSE, INC	HOSES FOR STREET EQUIPMENT, MOWERS ETC	11/6/2023	100303	132.41
		06040640 - 51070 -	Parts			
240148	3203	HASKELL LEMON CONSTRUCTION COMPANY	SS 1-H TACK COAT FOR POTHOLE PATCHER	11/6/2023	100312	81.60
		06040640 - 51105 -	Street Materials			
241863	2570	BOOT BARN	SAFETY WEAR FOR ANDREW FORMAN	11/7/2023	100465	179.98
		06040640 - 52355 -	Contract Services			
241864	2570	BOOT BARN	SAFETY WEAR FOR CHRIS CONNER	11/7/2023	100466	215.98
		06040640 - 52355 -	Contract Services			
241865	2570	BOOT BARN	SAFETY WEAR FOR ANTHONY MCKNIGHT	11/7/2023	100467	298.76
		06040640 - 52355 -	Contract Services			
241866	2570	BOOT BARN	SAFETY WEAR FOR AREEUS WILSON	11/7/2023	100470	179.98
		06040640 - 52355 -	Contract Services			
242042	154	TRAFFIC SIGNALS INC.	TRAFFIC SIGNAL/SCHOOL ZONE LIGHT REPAIRS ET	11/6/2023	100504	3,000.00
		06040640 - 52354 -	Outsource Labor			
242042	154	TRAFFIC SIGNALS INC.	TRAFFIC SIGNAL/SCHOOL ZONE LIGHT REPAIRS ET	11/8/2023	100505	500.00
		06040640 - 52354 -	Outsource Labor			
241935	859	HARD HAT SAFETY & GLOVE LLC	SAFETY GLOVES FOR PUBLIC WORKS	11/10/2023	100603	360.00
		06040640 - 51020 -	Safety Supplies			
240451	103	OKLAHOMA GAS & ELECTRIC	ELECTRICITY	11/16/2023	100666	1,220.25
		06040640 - 52100 -	Electricity			
240451	103	OKLAHOMA GAS & ELECTRIC	ELECTRICITY	11/17/2023	100790	49.59
		06040640 - 52100 -	Electricity			

Moore, OK Purchase Order Claim Register



Fund: 06 - General Fund

Check Run : 113023

Department: 064 - Public Works

P.O. #	Vendor #	Name	Summary Description	Date	Invoice	Amount
242191	2380	CINTAS CORPORATION #2	CONTRACT FY2023/2024 FOR UNIFORM CLEANING, MATS	8/30/2023	100795	163.98
		06040640 - 52355 -	Contract Services			
240452	103	OKLAHOMA GAS & ELECTRIC	ELECTRICITY COMBINED	11/17/2023	100835	488.45
		06040640 - 52100 -	Electricity			
240452	103	OKLAHOMA GAS & ELECTRIC	ELECTRICITY COMBINED	11/17/2023	100835	64,310.34
		06040640 - 52520 -	Street Lighting			
240200	1727	OKLAHOMA NATURAL GAS	NATURAL GAS, COMBINED	11/21/2023	100836	241.52
		06040640 - 52105 -	Natural Gas			
241489	72	LOWE'S BUSINESS ACCOUNT	MATERIALS AND SUPPLIES STREET DEPARTMENT	11/7/2023	100842	182.63
		06040640 - 51105 -	Street Materials			
242111	3408	TUS NUA LAWN AND LANDSCAPE, LLC	TUS NUA TEMP SERVICE CITY OF MOORE (2)	11/4/2023	100866	600.00
		06040640 - 52350 -	Temporary Labor			
242111	3408	TUS NUA LAWN AND LANDSCAPE, LLC	TUS NUA TEMP SERVICE CITY OF MOORE (2)	11/4/2023	100867	500.00
		06040640 - 52350 -	Temporary Labor			
242191	2380	CINTAS CORPORATION #2	CONTRACT FY2023/2024 FOR UNIFORM CLEANING, MATS	11/8/2023	100899	195.80
		06040640 - 52355 -	Contract Services			
242191	2380	CINTAS CORPORATION #2	CONTRACT FY2023/2024 FOR UNIFORM CLEANING, MATS	11/8/2023	100900	183.70
		06040640 - 52355 -	Contract Services			
242191	2380	CINTAS CORPORATION #2	CONTRACT FY2023/2024 FOR UNIFORM CLEANING, MATS	11/8/2023	100901	363.52
		06040640 - 52355 -	Contract Services			
242191	2380	CINTAS CORPORATION #2	CONTRACT FY2023/2024 FOR UNIFORM CLEANING, MATS	11/8/2023	100902	38.01
		06040640 - 52355 -	Contract Services			

Department Total : 78,474.57

Department: 065 - Animal Welfare

P.O. #	Vendor #	Name	Summary Description	Date	Invoice	Amount
241966	3240	LSBW, LLC	VET CARE FOR SHELTER ANIMALS	11/8/2023	100398	122.50
		06040650 - 52390 -	Veterinarian Services			
240200	1727	OKLAHOMA NATURAL GAS	NATURAL GAS, COMBINED	11/21/2023	100836	832.11
		06040650 - 52105 -	Natural Gas			
241962	3047	365 WORX, INC	TEMP. SERVICE (RITA RIZZO)	11/24/2023	100875	668.80
		06040650 - 52350 -	Temporary Labor			
240316	3096	CLASSEN URGENT CARE CLINIC LLC	MONTHLY PRE-EMPLOYMENT/RANDOM DRUG SCREENS	11/1/2023	100911	35.00
		06040650 - 52355 -	Contract Services			

Department Total : 1,658.41

Department: 068 - Fleet Maintenance

P.O. #	Vendor #	Name	Summary Description	Date	Invoice	Amount
241597	3716	HOLT TRUCK CENTERS OF OKLAHOMA, LLC	PARTS FOR CITY VEHICLES	11/7/2023	100325	124.70
		06040680 - 51070 -	Parts			

Moore, OK Purchase Order Claim Register



Fund: 06 - General Fund

Check Run : 113023

Department: 068 - Fleet Maintenance

P.O. #	Vendor #	Name	Summary Description	Date	Invoice	Amount
241685	1346	WINGFOOT COMMERCIAL TIRE SYSTEMS, LLC 06040680 - 51070 -	TIRES FOR CITY VEHICLES ET AL Parts	11/6/2023	100329	419.60
241383	908	RUSH TRUCK CENTER OF OKC, INC 06040680 - 51070 -	PARTS FOR CITY VEHICLES Parts	11/6/2023	100333	689.20
240443	194	MYERS BODYWORKS, INC. 06040680 - 52354 -	WORK, REPAIRS ECT. TO CITY VEHICLES Outsource Labor	11/7/2023	100336	67.50
240023	2025	M & N DEALERSHIPS XII LLC 06040680 - 51070 -	PARTS FOR CITY VEHICLES Parts	11/6/2023	100337	203.20
240023	2025	M & N DEALERSHIPS XII LLC 06040680 - 51070 -	PARTS FOR CITY VEHICLES Parts	11/7/2023	100338	460.10
240105	3720	GERARDO ESTRADA 06040680 - 52354 -	TIRE REPAIRS AND CHANGE OUTS ON SANITATION VEHICL Outsource Labor	11/6/2023	100339	140.00
240105	3720	GERARDO ESTRADA 06040680 - 52354 -	TIRE REPAIRS AND CHANGE OUTS ON SANITATION VEHICL Outsource Labor	11/7/2023	100340	100.00
240101	1751	EXPRESS OIL CHANGE 06040680 - 52354 -	OIL CHANGES FOR CITY VEHICLES Outsource Labor	11/8/2023	100341	34.99
240023	2025	M & N DEALERSHIPS XII LLC 06040680 - 51070 -	PARTS FOR CITY VEHICLES Parts	11/8/2023	100342	40.52
241507	189	O'REILLY AUTOMOTIVE INC 06040680 - 51070 -	PARTS FOR CITY VEHICLES Parts	11/6/2023	100345	77.39
241507	189	O'REILLY AUTOMOTIVE INC 06040680 - 51070 -	PARTS FOR CITY VEHICLES Parts	11/6/2023	100347	4.50
241507	189	O'REILLY AUTOMOTIVE INC 06040680 - 51070 -	PARTS FOR CITY VEHICLES Parts	11/6/2023	100348	22.50
241507	189	O'REILLY AUTOMOTIVE INC 06040680 - 51070 -	PARTS FOR CITY VEHICLES Parts	11/7/2023	100349	133.55
241507	189	O'REILLY AUTOMOTIVE INC 06040680 - 51070 -	PARTS FOR CITY VEHICLES Parts	11/7/2023	100350	544.34
241507	189	O'REILLY AUTOMOTIVE INC 06040680 - 51070 -	PARTS FOR CITY VEHICLES Parts	11/7/2023	100351	78.84
241507	189	O'REILLY AUTOMOTIVE INC 06040680 - 51070 -	PARTS FOR CITY VEHICLES Parts	11/7/2023	100352	5.69
241507	189	O'REILLY AUTOMOTIVE INC 06040680 - 51070 -	PARTS FOR CITY VEHICLES Parts	11/7/2023	100353	48.57
241507	189	O'REILLY AUTOMOTIVE INC 06040680 - 51070 -	PARTS FOR CITY VEHICLES Parts	11/8/2023	100354	8.03
241507	189	O'REILLY AUTOMOTIVE INC 06040680 - 51070 -	PARTS FOR CITY VEHICLES Parts	11/8/2023	100355	32.12
241378	4029	BANNER FIRE EQUIPMENT, INC 06040680 - 51070 -	PARTS FOR CITY VEHICLES Parts	11/8/2023	100399	2,075.01

Moore, OK Purchase Order Claim Register



Fund: 06 - General Fund

Check Run : 113023

Department: 068 - Fleet Maintenance

P.O. #	Vendor #	Name	Summary Description	Date	Invoice	Amount
240021	1313	CENTRAL OKLAHOMA HOSE, INC	PARTS FOR CITY VEHICLES	11/8/2023	100401	39.40
		06040680 - 51070 -	Parts			
240021	1313	CENTRAL OKLAHOMA HOSE, INC	PARTS FOR CITY VEHICLES	11/10/2023	100403	171.63
		06040680 - 51070 -	Parts			
241850	1755	HOME DEPOT CREDIT SERVICES	MISCELLANEOUS SUPPLIES, CHAINS, LOCKS, ET AL	11/9/2023	100404	383.07
		06040680 - 51250 -	Misc. Materials & Supplies			
241507	189	O'REILLY AUTOMOTIVE INC	PARTS FOR CITY VEHICLES	11/8/2023	100405	19.26
		06040680 - 51070 -	Parts			
241507	189	O'REILLY AUTOMOTIVE INC	PARTS FOR CITY VEHICLES	11/9/2023	100406	588.24
		06040680 - 51070 -	Parts			
241997	3164	AMAZON.COM SALES, INC.	WALL DROP BOX (GRAY)	11/6/2023	100408	75.99
		06040680 - 51150 -	Minor Equipment			
240105	3720	GERARDO ESTRADA	TIRE REPAIRS AND CHANGE OUTS ON SANITATION VEHICL	11/8/2023	100411	220.00
		06040680 - 52354 -	Outsource Labor			
240105	3720	GERARDO ESTRADA	TIRE REPAIRS AND CHANGE OUTS ON SANITATION VEHICL	11/8/2023	100412	40.00
		06040680 - 52354 -	Outsource Labor			
242045	908	RUSH TRUCK CENTER OF OKC, INC	PARTS FOR CITY VEHICLES	11/8/2023	100433	171.80
		06040680 - 51070 -	Parts			
240621	1824	PAT'S TOWING, INC	TOWING OF CITY VEHICLES	11/8/2023	100438	123.69
		06040680 - 52354 -	Outsource Labor			
241520	189	O'REILLY AUTOMOTIVE INC	20 PORTA POWER AND ACC	11/9/2023	100567	4,230.00
		06040680 - 53000 -	Equipment			
241507	189	O'REILLY AUTOMOTIVE INC	PARTS FOR CITY VEHICLES	11/7/2023	100572	88.47
		06040680 - 51070 -	Parts			
241507	189	O'REILLY AUTOMOTIVE INC	PARTS FOR CITY VEHICLES	11/7/2023	100573	6.77
		06040680 - 51070 -	Parts			
240022	1525	MOORE OIL & LUBE LLC	OIL CHANGES FOR CITY VEHICLES	11/9/2023	100788	72.95
		06040680 - 52354 -	Outsource Labor			
Department Total :						11,541.62

Department: 069 - Building Maintenance

P.O. #	Vendor #	Name	Summary Description	Date	Invoice	Amount
241942	2923	WARREN PRODUCTS, INC.	CALENDARS FOR 2024-BUILDING MAINTENANCE	11/6/2023	100234	28.75
		06040690 - 51000 -	General Office Supplies			
242005	35	DAVIS PIPE & SUPPLY, INC	MAGNETS FOR CHRISTMAS LIGHTS	11/7/2023	100297	339.00
		06040690 - 51100 -	Building Materials			
240964	71	LOCKE SUPPLY, INC.	MATERIALS AND SUPPLIES ET AL	11/7/2023	100298	5.76
		06040690 - 51100 -	Building Materials			
240964	71	LOCKE SUPPLY, INC.	MATERIALS AND SUPPLIES ET AL	11/8/2023	100427	38.88
		06040690 - 51100 -	Building Materials			
240964	71	LOCKE SUPPLY, INC.	MATERIALS AND SUPPLIES ET AL	11/10/2023	100428	26.54

Moore, OK Purchase Order Claim Register



Fund: 06 - General Fund

Check Run : 113023

Department: 069 - Building Maintenance

P.O. #	Vendor #	Name	Summary Description	Date	Invoice	Amount
		06040690 - 51100 -	Building Materials			
240807	3602	IDN-GLOBAL, INC.	BUILDING MAINTENANCE PARTS	11/8/2023	100459	470.00
		06040690 - 51100 -	Building Materials			
241647	2570	BOOT BARN	SAFETY BOOTS FOR DANIEL PITTMAN	11/7/2023	100469	193.49
		06040690 - 52355 -	Contract Services			
241645	2570	BOOT BARN	SAFETY BOOTS FOR JEFFREY SIMMONS	11/7/2023	100472	157.49
		06040690 - 52355 -	Contract Services			
241644	2570	BOOT BARN	SAFETY BOOTS FOR MARK LEACH	11/7/2023	100474	193.49
		06040690 - 52355 -	Contract Services			
241646	2570	BOOT BARN	SAFETY BOOTS FOR JOE COOPER	11/7/2023	100477	143.99
		06040690 - 52355 -	Contract Services			
Department Total :						1,597.39

Department: 070 - Parks & Recreation Admin

P.O. #	Vendor #	Name	Summary Description	Date	Invoice	Amount
240027	3164	AMAZON.COM SALES, INC.	(B) The Station - Special Event supplies	11/10/2023	100490	119.95
		06050700 - 52515 -	Special Events			
240027	3164	AMAZON.COM SALES, INC.	(B) The Station - Special Event supplies	11/11/2023	100492	206.59
		06050700 - 52515 -	Special Events			
240027	3164	AMAZON.COM SALES, INC.	(B) The Station - Special Event supplies	11/8/2023	100494	23.99
		06050700 - 52515 -	Special Events			
240027	3164	AMAZON.COM SALES, INC.	(B) The Station - Special Event supplies	11/9/2023	100495	25.88
		06050700 - 52515 -	Special Events			
240027	3164	AMAZON.COM SALES, INC.	(B) The Station - Special Event supplies	11/7/2023	100496	9.99
		06050700 - 52515 -	Special Events			
240027	3164	AMAZON.COM SALES, INC.	(B) The Station - Special Event supplies	11/8/2023	100497	178.32
		06050700 - 52515 -	Special Events			
240027	3164	AMAZON.COM SALES, INC.	(B) The Station - Special Event supplies	11/9/2023	100498	315.06
		06050700 - 52515 -	Special Events			
240451	103	OKLAHOMA GAS & ELECTRIC	ELECTRICITY	11/16/2023	100666	5,860.44
		06050700 - 52100 -	Electricity			
240494	1705	SAMS CLUB DIRECT	(B) The Station - Special event supplies	11/16/2023	100705	46.94
		06050700 - 52515 -	Special Events			
240494	1705	SAMS CLUB DIRECT	(B) The Station - Special event supplies	11/15/2023	100708	69.90
		06050700 - 52515 -	Special Events			
240452	103	OKLAHOMA GAS & ELECTRIC	ELECTRICITY COMBINED	11/17/2023	100835	314.08
		06050700 - 52100 -	Electricity			
240200	1727	OKLAHOMA NATURAL GAS	NATURAL GAS, COMBINED	11/21/2023	100836	589.26

Moore, OK Purchase Order Claim Register



Fund: 06 - General Fund

Check Run : 113023

Department: 070 - Parks & Recreation Admin

P.O. #	Vendor #	Name	Summary Description	Date	Invoice	Amount
		06050700 - 52105 -	Natural Gas			
240495	1734	WALMART COMMUNITY	(B) The Station - Special event supplies	11/28/2023	100878	18.26
		06050700 - 52515 -	Special Events			
Department Total :						7,778.66

Department: 071 - Senior Citizen Service

P.O. #	Vendor #	Name	Summary Description	Date	Invoice	Amount
240150	3139	DANIELLE G. MITCHELL	Contract Instructor Chair Yoga	11/25/2023	100782	25.00
		06050710 - 52590 -	Program Instructors			
241397	3571	RICHARD GONZALEZ	Contract Services Bus Driver	11/25/2023	100783	281.75
		06050710 - 52355 -	Contract Services			
240452	103	OKLAHOMA GAS & ELECTRIC	ELECTRICITY COMBINED	11/17/2023	100835	735.89
		06050710 - 52100 -	Electricity			
240200	1727	OKLAHOMA NATURAL GAS	NATURAL GAS, COMBINED	11/21/2023	100836	300.93
		06050710 - 52105 -	Natural Gas			
Department Total :						1,343.57

Department: 073 - Parks & Recreation Activities

P.O. #	Vendor #	Name	Summary Description	Date	Invoice	Amount
240085	1705	SAMS CLUB DIRECT	(B) Supplies/snacks for classes/camps	11/17/2023	100707	75.36
		06050730 - 52585 -	Recreation Classes			
240034	1734	WALMART COMMUNITY	(B) Supplies/snacks for classes/camps	11/28/2023	100879	54.94
		06050730 - 52585 -	Recreation Classes			
242220	3847	MCCALL, JENNIFER J	Spanish 12-2-23	11/28/2023	100906	25.00
		06050730 - 52590 -	Program Instructors			
240316	3096	CLASSEN URGENT CARE CLINIC LLC	MONTHLY PRE-EMPLOYMENT/RANDOM DRUG SCREENS	11/1/2023	100911	910.00
		06050730 - 52545 -	Misc Services & Charges			
242225	844	SCOTT HODGES	Thanksgiving Break Basketball Camp 2023	11/29/2023	100937	420.00
		06050730 - 52590 -	Program Instructors			
242227	1456	DAKOTA FOSTER	Thanksgiving Break Basketball Camp Assistant 2023	11/29/2023	100938	150.00
		06050730 - 52590 -	Program Instructors			
Department Total :						1,635.30

Department: 074 - Parks & Cemetery Maintenance

P.O. #	Vendor #	Name	Summary Description	Date	Invoice	Amount
241775	2570	BOOT BARN	Safety boots & cold weather gear for Larry Roat	11/7/2023	100245	-211.49
		06050740 - 51020 -	Safety Supplies			
242009	2570	BOOT BARN	Safety footwear for Larry Roat	11/7/2023	100248	200.00
		06050740 - 51020 -	Safety Supplies			
240158	1755	HOME DEPOT CREDIT SERVICES	(B) Parks Maintenance - Materials, supplies	11/15/2023	100709	87.80
		06050740 - 51250 -	Misc. Materials & Supplies			

Moore, OK Purchase Order Claim Register



Fund: 06 - General Fund

Check Run : 113023

Department: 074 - Parks & Cemetery Maintenance

P.O. #	Vendor #	Name	Summary Description	Date	Invoice	Amount
240158	1755	HOME DEPOT CREDIT SERVICES	(B) Parks Maintenance - Materials, supplies	11/17/2023	100711	103.76
		06050740 - 51250 -	Misc. Materials & Supplies			
240011	72	LOWE'S BUSINESS ACCOUNT	(B) Parks Maintenance materials/supplies	11/15/2023	100715	96.94
		06050740 - 51250 -	Misc. Materials & Supplies			
240011	72	LOWE'S BUSINESS ACCOUNT	(B) Parks Maintenance materials/supplies	11/16/2023	100882	198.80
		06050740 - 51250 -	Misc. Materials & Supplies			
240179	3601	FARRIS D SMITH	Re Paint Poles at Amphitheatre at Central Park	11/26/2023	100884	2,250.00
		06050740 - 52170 -	Special Projects			
242094	1941	DISPLAY SALES	Straps; banner rods for parks	11/15/2023	100933	674.50
		06050740 - 51250 -	Misc. Materials & Supplies			
240011	72	LOWE'S BUSINESS ACCOUNT	(B) Parks Maintenance materials/supplies	11/1/2023	100936	41.71
		06050740 - 51250 -	Misc. Materials & Supplies			

Department Total : 3,442.02

Department: 075 - Moore Recreation Center

P.O. #	Vendor #	Name	Summary Description	Date	Invoice	Amount
242003	1214	MOORE TAG AGENCY, INC	TRUCK FOR PARKS AND REC	11/6/2023	100209	51.00
		06050750 - 51150 -	Minor Equipment			
242035	3979	JOSIE GARRARD	Yoga Class 10/24/23 10/31/23	11/8/2023	100334	50.00
		06050750 - 52590 -	Program Instructors			
240848	3164	AMAZON.COM SALES, INC.	(B) The Station - Office supplies	11/6/2023	100499	18.92
		06050750 - 51000 -	General Office Supplies			
241930	74	MATTOCKS PRINTING CO. LLC	The Station - Youth Basketball punch cards (500)	11/10/2023	100506	48.00
		06050750 - 52000 -	Printing & Publications			
241198	1208	NETWORK SERVICES COMPANY	(B) The Station - Ron's custodial supplies	11/8/2023	100509	557.33
		06050750 - 51010 -	Janitorial/Custodial Supplies			
240361	2380	CINTAS CORPORATION #2	(B) Parks & Rec - Contract uniform cleaning	11/8/2023	100510	186.84
		06050750 - 52355 -	Contract Services			
240361	2380	CINTAS CORPORATION #2	(B) Parks & Rec - Contract uniform cleaning	11/8/2023	100511	91.68
		06050750 - 52355 -	Contract Services			
242012	3655	BASKETBALL PRODUCTS INTERNATIONAL	Repair parts for Gym BB goals	11/9/2023	100541	820.00
		06050750 - 52255 -	Minor Equip Maint/Lease			
240411	1705	SAMS CLUB DIRECT	(B) The Station - Supplies for fitness classes	11/17/2023	100706	278.00
		06050750 - 52585 -	Recreation Classes			
240159	1755	HOME DEPOT CREDIT SERVICES	(B) The Station - Ron's maintenance supplies	11/16/2023	100714	67.15
		06050750 - 52255 -	Minor Equip Maint/Lease			
241198	1208	NETWORK SERVICES COMPANY	(B) The Station - Ron's custodial supplies	11/10/2023	100744	1,841.12
		06050750 - 51010 -	Janitorial/Custodial Supplies			

Moore, OK Purchase Order Claim Register



Fund: 06 - General Fund

Check Run : 113023

Department: 075 - Moore Recreation Center

P.O. #	Vendor #	Name	Summary Description	Date	Invoice	Amount
242202	3214	SJ INNOVATIONS LLC	The Station security - 11/5/23-11/18/23	11/20/2023	100883	5,257.61
		06050750 - 52353 -	Security			
240316	3096	CLASSEN URGENT CARE CLINIC LLC	MONTHLY PRE-EMPLOYMENT/RANDOM DRUG SCREENS	11/1/2023	100911	70.00
		06050750 - 52360 -	Professional Services			
242224	187	NATIONAL RECREATION AND PARK ASSOCIATION	CAPRA extension	11/27/2023	100930	1,100.00
		06050750 - 52005 -	Dues, Mbrshps, Mtgs & Training			
Department Total :						10,437.65

Department: 077 - Library

P.O. #	Vendor #	Name	Summary Description	Date	Invoice	Amount
240200	1727	OKLAHOMA NATURAL GAS	NATURAL GAS, COMBINED	11/21/2023	100836	384.52
		06050770 - 52105 -	Natural Gas			
Department Total :						384.52

Department: 081 - Inspections

P.O. #	Vendor #	Name	Summary Description	Date	Invoice	Amount
242104	2936	CHAD DENSON	Training Event International code conference exp	10/8/2023	100627	1,270.01
		06060810 - 52005 -	Dues, Mbrshps, Mtgs & Training			
241015	72	LOWE'S BUSINESS ACCOUNT	Tools & Supplies	10/18/2023	100912	36.98
		06060810 - 51000 -	General Office Supplies			
241015	72	LOWE'S BUSINESS ACCOUNT	Tools & Supplies	11/28/2023	100922	-2.90
		06060810 - 51000 -	General Office Supplies			
242230	600	CONSTRUCTION INDUSTRIES BOARD	Yearly Renewal for Dennis Wall's State Insp licens	11/29/2023	100939	35.00
		06060810 - 52005 -	Dues, Mbrshps, Mtgs & Training			
Department Total :						1,339.09

Department: 082 - Code Enforcement

P.O. #	Vendor #	Name	Summary Description	Date	Invoice	Amount
242086	3468	FRANCISCO ALEJO MARCOS	Abatements	11/7/2023	100727	160.00
		06060820 - 52355 -	Contract Services			
242102	4054	PLAINS MOVING, LLC	Abatements	11/15/2023	100747	438.89
		06060820 - 52355 -	Contract Services			
242102	4054	PLAINS MOVING, LLC	Abatements	11/15/2023	100748	374.38
		06060820 - 52355 -	Contract Services			
242102	4054	PLAINS MOVING, LLC	Abatements	11/15/2023	100749	284.38
		06060820 - 52355 -	Contract Services			
242102	4054	PLAINS MOVING, LLC	Abatements	11/15/2023	100750	1,710.00
		06060820 - 52355 -	Contract Services			
242179	4054	PLAINS MOVING, LLC	Abatements	11/21/2023	100822	546.64
		06060820 - 52355 -	Contract Services			
242179	4054	PLAINS MOVING, LLC	Abatements	11/17/2023	100823	1,153.97
		06060820 - 52355 -	Contract Services			
242179	4054	PLAINS MOVING, LLC	Abatements	11/15/2023	100824	158.89

Moore, OK Purchase Order Claim Register



Fund: 06 - General Fund

Check Run : 113023

Department: 082 - Code Enforcement

P.O. #	Vendor #	Name	Summary Description	Date	Invoice	Amount
		06060820 - 52355 -	Contract Services			
242179	4054	PLAINS MOVING, LLC	Abatements	11/15/2023	100825	228.89
		06060820 - 52355 -	Contract Services			
242179	4054	PLAINS MOVING, LLC	Abatements	11/15/2023	100826	158.89
		06060820 - 52355 -	Contract Services			
242179	4054	PLAINS MOVING, LLC	Abatements	11/15/2023	100827	168.89
		06060820 - 52355 -	Contract Services			
Department Total :						5,383.82

Department: 083 - Capital Planning & Resiliency

P.O. #	Vendor #	Name	Summary Description	Date	Invoice	Amount
242054	2748	SUNDANCE OFFICE SUPPLY, INC.	Black/Cyan/Magenta/Yellow Ink; Paper Clips	11/9/2023	100610	351.62
		06060830 - 51000 -	General Office Supplies			
Department Total :						351.62
Fund Total :						165,751.03

Moore, OK Purchase Order Claim Register



Fund: 08 - Special Revenue Fund **Check Run : 113023**

Department: 214 - CDBG Entitlement

P.O. #	Vendor #	Name	Summary Description	Date	Invoice	Amount
241912	3160	EL NACIONAL NEWS	11/02/2023 Public Notice: FY 2022 CAPER	11/8/2023	100874	435.00
	08042140 - 55117 -		CDBG 2023			
Department Total :						435.00

Department: 220 - Transportation Impact Fees

P.O. #	Vendor #	Name	Summary Description	Date	Invoice	Amount
234437	3516	TEIM DESIGN GROUP, PLLC	NW 27TH STREET AND SHIELDS BLVD INTERSECTION	11/8/2023	100402	30,205.48
	08032200 - 55425 -		Transportation Impact Projects			
Department Total :						30,205.48
Fund Total :						30,640.48

Moore, OK Purchase Order Claim Register



Fund: 10 - Urban Renewal Authority

Check Run : 113023

Department: 000 - Undesignated

P.O. #	Vendor #	Name	Summary Description	Date	Invoice	Amount
242063	1102	CENTER FOR ECONOMIC DEVELOPMENT LAW 10 - 53225 -	LEGAL SERVICES CLEVELAND HEIGHTS - MPS Cleveland Heights	11/8/2023	100473	617.50
242103	1102	CENTER FOR ECONOMIC DEVELOPMENT LAW 10 - 53225 -	LEGAL SERVICES THRU 10/31/2023 CLEVELAND HEIGHTS Cleveland Heights	11/8/2023	100595	6,496.43
242193	309	CLEVELAND COUNTY 10 - 54320 -	COMMISSIONERS FEES CASE # CJ-2023-1145 Land	11/20/2023	100798	6,760.00
242193	309	CLEVELAND COUNTY 10 - 54320 -	COMMISSIONERS FEES CASE # CJ-2023-1145 Land	11/20/2023	100799	1,800.00
242193	309	CLEVELAND COUNTY 10 - 54320 -	COMMISSIONERS FEES CASE # CJ-2023-1145 Land	11/20/2023	100800	105.60
242192	309	CLEVELAND COUNTY 10 - 54320 -	COMMISSIONERS FEES CASE # CJ-2023-1146 Land	11/20/2023	100801	7,160.00
242192	309	CLEVELAND COUNTY 10 - 54320 -	COMMISSIONERS FEES CASE # CJ-2023-1146 Land	11/20/2023	100802	1,800.00
242192	309	CLEVELAND COUNTY 10 - 54320 -	COMMISSIONERS FEES CASE # CJ-2023-1146 Land	11/20/2023	100803	109.60

Department Total :	24,849.13
Fund Total :	24,849.13

Moore, OK Purchase Order Claim Register



Fund: 12 - 1/2 Cent Sales Tax

Check Run : 113023

Department: 580 - Public Safety Equipment

P.O. #	Vendor #	Name	Summary Description	Date	Invoice	Amount
242101	4068	ARCHANGEL DEVICE LLC	45 Red/blue Infrared hybrid elite series	11/16/2023	100910	5,624.55
		12025800 - 53000 -	Equipment			
Department Total :						5,624.55
Fund Total :						5,624.55

**CLAIMS FOR RATIFICATION
Fiscal Year 2023-2024
DISTRIBUTION DECEMBER 01, 2023
COUNCIL MEETING DECEMBER 18, 2023**

CITY OF MOORE

General Fund	(06)	\$	30,000.00
	Fund Total	\$	<u>30,000.00</u>

MOORE PUBLIC WORKS AUTHORITY

	Fund Total	\$	<u>-</u>
--	-------------------	-----------	-----------------

	ALL FUNDS GRAND TOTAL	\$	<u><u>30,000.00</u></u>
--	------------------------------	-----------	--------------------------------

CLAIMS FOR RATIFICATION

MOORE CITY COUNCIL

COUNCIL MEETING DECEMBER 18, 2023

Moore City Council
General Fund 2023-2024
Vendor & Employee Claims

Moore, OK Purchase Order Claim Register



Fund: 06 - General Fund

Check Run : 120123

Department: 044 - Information Technology

P.O. #	Vendor #	Name	Summary Description	Date	Invoice	Amount
242248	2726	PROFESSIONAL AND TECHNICAL SOFTWARE SOLUTIONS, INC	ANNUAL SOFTWARE MAINTENANCE	9/28/2023	100990	30,000.00
	06010440 - 52485 -		IT Licenses & Permits			

Department Total :	30,000.00
Fund Total :	30,000.00

**CLAIMS FOR RATIFICATION
Fiscal Year 2023-2024
DISTRIBUTION DECEMBER 07, 2023
COUNCIL MEETING DECEMBER 18, 2023**

CITY OF MOORE

GO Street Bonds	(04)	\$	282,909.81
General Fund	(06)	\$	277,599.75
Special Revenue Fund	(08)	\$	8,118.26
Debt Service Fund	(09)	\$	1,893,256.25
Stormwater Systems	(11)	\$	40,424.12
Public Safety/Streets Sales Tax	(12)	\$	3,319.65
Parks/Public Works Sales Tax	(13)	\$	528,745.29
	Fund Total	\$	<u>3,034,373.13</u>

MOORE PUBLIC WORKS AUTHORITY

Moore Risk Management	(02)	\$	7,515.58
Moore Public Works	(05)	\$	301,254.28
	Fund Total	\$	<u>308,769.86</u>

ALL FUNDS GRAND TOTAL **\$ 3,343,142.99**

CLAIMS FOR RATIFICATION

MOORE CITY COUNCIL

COUNCIL MEETING DECEMBER 18, 2023

Moore City Council
General Fund 2023-2024
Vendor & Employee Claims

Moore, OK Purchase Order Claim Register



Fund: 04 - Street Bond Improvements

Check Run : 120723

Department: 531 - 2019 GO Street/Drainage

P.O. #	Vendor #	Name	Summary Description	Date	Invoice	Amount
200948	2895	FREESE AND NICHOLS, INC	CC APPROVED 08/19/19 ENGINEERING SERVICES	11/14/2023	101035	5,000.00
		04035310 - 54315 - 12002	Engineering			
Department Total :						5,000.00

Department: 533 - 2021 GO Street/Drainage

P.O. #	Vendor #	Name	Summary Description	Date	Invoice	Amount
241174	934	VEOLIA WATER NORTH AMERICA	REPAIR & MAINTENANCE (costs in excess)	10/23/2023	100978	78,823.39
		04035330 - 54300 - 12001	Construction			
241174	934	VEOLIA WATER NORTH AMERICA	REPAIR & MAINTENANCE (costs in excess)	10/23/2023	100978	102,901.21
		04035330 - 54300 - 12005	Construction			
Department Total :						181,724.60

Department: 534 - 2022 GO Streets/Animal Shelter

P.O. #	Vendor #	Name	Summary Description	Date	Invoice	Amount
223183	2895	FREESE AND NICHOLS, INC	PROFESSION ENGINEERING SRVS -TELEPHONE ROAD	11/14/2023	101033	7,293.71
		04035340 - 54315 - 12017	Engineering			
223181	735	EST, INC.	PROFESSIONAL ENGINEERING DESIGN SERVS-	10/15/2023	101036	38,765.76
		04035340 - 54315 - 12015	Engineering			
223181	735	EST, INC.	PROFESSIONAL ENGINEERING DESIGN SERVS-	10/15/2023	101036	19,970.24
		04035340 - 54315 - 12016	Engineering			
223181	735	EST, INC.	PROFESSIONAL ENGINEERING DESIGN SERVS-	10/30/2023	101042	4,844.66
		04035340 - 54315 - 12015	Engineering			
223181	735	EST, INC.	PROFESSIONAL ENGINEERING DESIGN SERVS-	10/30/2023	101042	2,495.74
		04035340 - 54315 - 12016	Engineering			
223181	735	EST, INC.	PROFESSIONAL ENGINEERING DESIGN SERVS-	11/14/2023	101045	15,057.97
		04035340 - 54315 - 12015	Engineering			
223181	735	EST, INC.	PROFESSIONAL ENGINEERING DESIGN SERVS-	11/14/2023	101045	7,757.13
		04035340 - 54315 - 12016	Engineering			
Department Total :						96,185.21
Fund Total :						282,909.81

Moore, OK Purchase Order Claim Register



Fund: 06 - General Fund

Check Run : 120723

Department: 000 - Undesignated

P.O. #	Vendor #	Name	Summary Description	Date	Invoice	Amount
		1 ONE TIME PAY VENDOR	BONDREF 231704834 M.JOHN	11/15/2023	100622	50.00
		6 - 21030 -	Refunds Payable			
		1 ONE TIME PAY VENDOR	BONDREF 231704435 M.FARMER	11/15/2023	100623	70.00
		6 - 21030 -	Refunds Payable			
242108	189	O'REILLY AUTOMOTIVE INC	PARTS FOR CITY VEHICLES	11/14/2023	100629	1,176.48
		6 - 12052 -	Fleet Inventory			
240642	342	OKLAHOMA STATE BUREAU	AFIS/FORENSIC FEES	11/1/2023	101098	13,633.93
		6 - 20205 -	CLEET Fees Outstanding			
240791	1301	OKLA BUREAU OF NARCOTICS	NARC FEES	11/1/2023	101099	75.00
		6 - 20220 -	Bureau Narc Drug Edu Fund			
240198	725	CLEET	PENALTY ASSESSMENT FEES	11/1/2023	101100	6,481.52
		6 - 20205 -	CLEET Fees Outstanding			
Department Total :						21,486.93

Department: 005 - Fines, Forfeitures & Seizures

P.O. #	Vendor #	Name	Summary Description	Date	Invoice	Amount
240642	342	OKLAHOMA STATE BUREAU	AFIS/FORENSIC FEES	11/1/2023	101098	-396.60
		06020050 - 45000 -	Court Fines & Fees			
240198	725	CLEET	PENALTY ASSESSMENT FEES	11/1/2023	101100	-52.12
		06020050 - 45000 -	Court Fines & Fees			
Department Total :						-448.72

Department: 035 - General Government

P.O. #	Vendor #	Name	Summary Description	Date	Invoice	Amount
240451	103	OKLAHOMA GAS & ELECTRIC	ELECTRICITY	11/22/2023	100905	59.60
		06010350 - 52100 -	Electricity			
242209	92	NORMAN TRANSCRIPT	RESOLUTION# 68 (23) PUBLICATION	11/16/2023	100913	142.20
		06010350 - 52000 -	Printing & Publications			
242237	1516	FIRST FIDELITY BANK, NA	Public Affairs Visa Card 1193 Due 12-15-23	11/18/2023	100958	10.00
		06010350 - 52005 -	Dues, Mbrshps, Mtgs & Training			
242239	3798	CIVICPLUS, LLC	MUNICODE ANNUAL SELF PUBLISHING SOFTWARE LICENSE	10/1/2023	100967	3,595.00
		06010350 - 52475 -	Software Maintenance Fees			
240421	1872	WRIGHT EXPRESS FSC	CITY WIDE FUEL USAGE	11/30/2023	101020	108.74
		06010350 - 51075 -	Fuel			
241598	2855	PRESORT FIRST CLASS	CITY OF MOORE BUDGET BOOK	11/28/2023	101092	2,509.50
		06010350 - 52000 -	Printing & Publications			
Department Total :						6,425.04

Department: 043 - Finance

P.O. #	Vendor #	Name	Summary Description	Date	Invoice	Amount
241820	76	CRAWFORD & ASSOCIATES P.C	PROFESSIONAL SERVICES THRU 09/15/2023	11/15/2023	100919	6,135.00
		06010430 - 52365 -	Accounting & Audit Expense			
Department Total :						6,135.00

Moore, OK Purchase Order Claim Register



Fund: 06 - General Fund

Check Run : 120723

Department: 044 - Information Technology

P.O. #	Vendor #	Name	Summary Description	Date	Invoice	Amount
241041	422	CHICKASAW TELECOM, INC.	Network Switches	11/13/2023	100525	24,427.21
		06010440 - 53000 -	Equipment			
242091	422	CHICKASAW TELECOM, INC.	Telephone repair	11/14/2023	100556	148.00
		06010440 - 52110 -	Telephone			
242171	1661	SHOTROK, LLC	Fire 1 Door card repair	11/19/2023	100728	321.68
		06010440 - 52120 -	Security Services			
242070	3164	AMAZON.COM SALES, INC.	Open PO for Amazon	11/16/2023	100729	43.46
		06010440 - 51150 -	Minor Equipment			
240051	3164	AMAZON.COM SALES, INC.	Open PO for amazon	11/16/2023	100730	369.98
		06010440 - 51150 -	Minor Equipment			
242070	3164	AMAZON.COM SALES, INC.	Open PO for Amazon	11/16/2023	100731	134.66
		06010440 - 51150 -	Minor Equipment			
240440	3610	OKLAHOMA STATE REGENTS FOR HIGHER EDUCATION	Backup internet for city hall	10/31/2023	100996	1,240.00
		06010440 - 52135 -	Internet Expense			
240671	944	CELLCO PARTNERSHIP	Verizon bill for July-December 2023	11/10/2023	100999	90.04
		06010440 - 52130 -	Wireless Tech Licenses			

Department Total : 26,775.03

Department: 046 - Public Affairs

P.O. #	Vendor #	Name	Summary Description	Date	Invoice	Amount
242114	3164	AMAZON.COM SALES, INC.	LAZY SUSAN STANDS FOR COMPUTER MONITORS	11/19/2023	100647	67.90
		06010460 - 51000 -	General Office Supplies			
240169	834	DOTMAN GRAPHIC DESIGN INC	Web development from July 1st to June 30th, 2024	12/1/2023	101000	1,400.00
		06010460 - 52150 -	Web Site Development & Mainten			

Department Total : 1,467.90

Department: 050 - Municipal Court

P.O. #	Vendor #	Name	Summary Description	Date	Invoice	Amount
242095	2923	WARREN PRODUCTS, INC.	CALENDARS FOR 2024-COURT CLERKS OFFICE	11/16/2023	100774	194.19
		06020500 - 51000 -	General Office Supplies			

Department Total : 194.19

Department: 051 - Police

P.O. #	Vendor #	Name	Summary Description	Date	Invoice	Amount
240421	1872	WRIGHT EXPRESS FSC	CITY WIDE FUEL USAGE	11/30/2023	101020	16,605.19
		06020510 - 51075 -	Fuel			
242231	448	SPECIAL OPS UNIFORMS	Underbelt (difference from previous PO 241772)	11/27/2023	101155	19.51
		06020510 - 51225 -	Uniform Acquisition/Rental			
242262	2689	PIVOT, INC	CIC Services 4th Qtr. FY 2023	6/30/2023	101156	4,000.00
		06020510 - 52535 -	City Share Intervention Ctr			
242264	2344	KRISTEN'S ALTERATIONS	Bartlett & Henderson uniform alterations	11/13/2023	101157	68.00
		06020510 - 51225 -	Uniform Acquisition/Rental			
242264	2344	KRISTEN'S ALTERATIONS	Bartlett & Henderson uniform alterations	11/14/2023	101158	36.00

Moore, OK Purchase Order Claim Register



Fund: 06 - General Fund

Check Run : 120723

Department: 051 - Police

P.O. #	Vendor #	Name	Summary Description	Date	Invoice	Amount
		06020510 - 51225 -	Uniform Acquisition/Rental			
242265	2344	KRISTEN'S ALTERATIONS	Evans uniform alterations	11/20/2023	101159	48.00
		06020510 - 51225 -	Uniform Acquisition/Rental			
242267	3683	GUARDIAN ALLIANCE TECHNOLOGIES, INC.	5 PS Applicants & 1 social media screening app	11/30/2023	101160	290.00
		06020510 - 52008 -	Recruitment			
242276	2344	KRISTEN'S ALTERATIONS	McKinney uniform alterations	11/18/2023	101161	65.00
		06020510 - 51225 -	Uniform Acquisition/Rental			
242180	74	MATTOCKS PRINTING CO. LLC	100 Christmas cards	11/29/2023	101163	90.00
		06020510 - 52000 -	Printing & Publications			
242206	3164	AMAZON.COM SALES, INC.	cord cover for Christmas tree on stairs	11/29/2023	101164	15.33
		06020510 - 51150 -	Minor Equipment			
Department Total :						21,237.03

Department: 052 - Communications/Dispatch

P.O. #	Vendor #	Name	Summary Description	Date	Invoice	Amount
242169	74	MATTOCKS PRINTING CO. LLC	30 count christmas cards	11/30/2023	101162	40.00
		06020520 - 52000 -	Printing & Publications			
Department Total :						40.00

Department: 053 - Emergency Management

P.O. #	Vendor #	Name	Summary Description	Date	Invoice	Amount
242056	3164	AMAZON.COM SALES, INC.	TONERS- 4EA (728)	11/9/2023	100773	527.00
		06020530 - 51000 -	General Office Supplies			
240421	1872	WRIGHT EXPRESS FSC	CITY WIDE FUEL USAGE	11/30/2023	101020	245.36
		06020530 - 51075 -	Fuel			
Department Total :						772.36

Department: 054 - Fire

P.O. #	Vendor #	Name	Summary Description	Date	Invoice	Amount
240120	3164	AMAZON.COM SALES, INC.	air Spring Activation Switch	11/16/2023	100673	17.79
		06020540 - 51070 -	Parts			
242132	2809	GREGORY'S SPORTING GOODS, INC	MFD Stocking Caps	11/14/2023	100688	90.00
		06020540 - 51225 -	Uniform Acquisition/Rental			
241608	1705	SAMS CLUB DIRECT	Supplies for MFD Janitorial / Office	11/16/2023	100724	105.72
		06020540 - 51010 -	Janitorial/Custodial Supplies			
241733	2380	CINTAS CORPORATION #2	Uniform Pants Rental & Cleaning	11/13/2023	100740	335.54
		06020540 - 52250 -	Uniform Cleaning & Repair			
241733	2380	CINTAS CORPORATION #2	Uniform Pants Rental & Cleaning	11/17/2023	100743	335.54
		06020540 - 52250 -	Uniform Cleaning & Repair			
242037	4029	BANNER FIRE EQUIPMENT, INC	Interior Panel Rivet E-ONE	11/16/2023	100775	299.00
		06020540 - 51070 -	Parts			
240421	1872	WRIGHT EXPRESS FSC	CITY WIDE FUEL USAGE	11/30/2023	101020	5,487.65

Moore, OK Purchase Order Claim Register



Fund: 06 - General Fund

Check Run : 120723

Department: 054 - Fire

P.O. #	Vendor #	Name	Summary Description	Date	Invoice	Amount
		06020540 - 51075 -	Fuel			
Department Total :						6,671.24

Department: 064 - Public Works

P.O. #	Vendor #	Name	Summary Description	Date	Invoice	Amount
241665	3863	A & A LAWN CARE SERVICE LLC	TEMP WORK FOR CITY OF MOORE STREET DEPARTMENT	11/13/2023	100419	2,400.00
		06040640 - 52350 -	Temporary Labor			
240097	726	EUREKA WATER COMPANY	DRINKING WATER ADMINISTRATIVE BLDG	11/14/2023	100604	7.45
		06040640 - 51250 -	Misc. Materials & Supplies			
241594	1705	SAMS CLUB DIRECT	OFFICE SUPPLIES, WATER, GATORADE ECT	11/16/2023	100648	197.66
		06040640 - 51250 -	Misc. Materials & Supplies			
241594	1705	SAMS CLUB DIRECT	OFFICE SUPPLIES, WATER, GATORADE ECT	11/16/2023	100649	4.96
		06040640 - 51250 -	Misc. Materials & Supplies			
240451	103	OKLAHOMA GAS & ELECTRIC	ELECTRICITY	11/21/2023	100837	90.80
		06040640 - 52100 -	Electricity			
240139	724	JONES TIRE, LLC	REPAIRS FOR TRAILERS WHEELS ETC	11/15/2023	100839	752.00
		06040640 - 52354 -	Outsource Labor			
241756	4050	CONSOLIDATED TRAFFIC CONTROLS, INC.	AC & DC SCHOOL ZONE TIMER UPGRADES	11/14/2023	100840	70,774.00
		06040640 - 53000 -	Equipment			
241489	72	LOWE'S BUSINESS ACCOUNT	MATERIALS AND SUPPLIES STREET DEPARTMENT	11/15/2023	100843	42.73
		06040640 - 51105 -	Street Materials			
240145	1755	HOME DEPOT CREDIT SERVICES	STREET MATERIALS FOR STREET DEPARTMENT	11/17/2023	100849	830.29
		06040640 - 51105 -	Street Materials			
241506	189	O'REILLY AUTOMOTIVE INC	SUPPLIES FOR STREET DEPARTMENT EQUIPMENT ETC	11/14/2023	100850	21.12
		06040640 - 51105 -	Street Materials			
241506	189	O'REILLY AUTOMOTIVE INC	SUPPLIES FOR STREET DEPARTMENT EQUIPMENT ETC	11/14/2023	100851	39.98
		06040640 - 51105 -	Street Materials			
240136	596	NEWMAN SIGNS, INC	BLANKET PO SIGN BLANKS FOR STREET SIGNS/MARKERS	11/16/2023	100865	127.85
		06040640 - 51105 -	Street Materials			
240451	103	OKLAHOMA GAS & ELECTRIC	ELECTRICITY	11/22/2023	100905	176.94
		06040640 - 52100 -	Electricity			
240129	235	FIRST AID EXPRESS	STOCKING MEDICINE CABINET	8/28/2023	100973	113.00
		06040640 - 51020 -	Safety Supplies			
240421	1872	WRIGHT EXPRESS FSC	CITY WIDE FUEL USAGE	11/30/2023	101020	3,563.63
		06040640 - 51075 -	Fuel			
240425	3191	DENNIS A BOTHELL	PROFESSIONAL SERVICE AGREEMENT DENNIS BOTHELL	12/1/2023	101030	945.00
		06040640 - 52360 -	Professional Services			

Moore, OK Purchase Order Claim Register



Fund: 06 - General Fund

Check Run : 120723

Department: 064 - Public Works

P.O. #	Vendor #	Name	Summary Description	Date	Invoice	Amount
241377	2570	BOOT BARN	SAFETY BOOTS FOR KARL STEVENSON	10/20/2023	101133	148.49
		06040640 - 52355 -	Contract Services			
241516	2570	BOOT BARN	SAFETY BOOTS FOR ROBERT MCKINLEY	10/20/2023	101135	193.49
		06040640 - 52355 -	Contract Services			
241408	2570	BOOT BARN	SAFETY BOOTS FOR DUANE GREEN	10/20/2023	101136	143.99
		06040640 - 52355 -	Contract Services			
241266	2570	BOOT BARN	SAFETY BOOTS FOR RICHARD ELI MEANS	10/20/2023	101137	134.99
		06040640 - 52355 -	Contract Services			

Department Total : 80,708.37

Department: 065 - Animal Welfare

P.O. #	Vendor #	Name	Summary Description	Date	Invoice	Amount
240237	72	LOWE'S BUSINESS ACCOUNT	shelter supplies / hoses/ etc.	11/15/2023	100588	36.30
		06040650 - 51065 -	Animal Shelter Supplies			
241060	3240	LSBW, LLC	VET SERVICES FOR ANIMALS	11/14/2023	100589	175.50
		06040650 - 52390 -	Veterinarian Services			
241060	3240	LSBW, LLC	VET SERVICES FOR ANIMALS	11/15/2023	100591	471.09
		06040650 - 52390 -	Veterinarian Services			
242078	1068	PETSMART, INC	shelter supplies and animal food	11/15/2023	100592	49.46
		06040650 - 51065 -	Animal Shelter Supplies			
241889	1253	ANIMAL HEALTH INTERNATIONAL, INC	animal euthanasia, meds	11/13/2023	100593	119.40
		06040650 - 51065 -	Animal Shelter Supplies			
241889	1253	ANIMAL HEALTH INTERNATIONAL, INC	animal euthanasia, meds	11/13/2023	100594	459.18
		06040650 - 51065 -	Animal Shelter Supplies			
242109	1253	ANIMAL HEALTH INTERNATIONAL, INC	additional euth. supplies	11/13/2023	100596	93.75
		06040650 - 51065 -	Animal Shelter Supplies			
241060	3240	LSBW, LLC	VET SERVICES FOR ANIMALS	11/16/2023	100607	139.49
		06040650 - 52390 -	Veterinarian Services			
241966	3240	LSBW, LLC	VET CARE FOR SHELTER ANIMALS	11/17/2023	100616	175.50
		06040650 - 52390 -	Veterinarian Services			
242221	235	FIRST AID EXPRESS	First Aide for shelter	11/8/2023	100950	42.75
		06040650 - 51020 -	Safety Supplies			
240239	1734	WALMART COMMUNITY	shelter supplies	11/28/2023	100951	153.38
		06040650 - 51065 -	Animal Shelter Supplies			
240421	1872	WRIGHT EXPRESS FSC	CITY WIDE FUEL USAGE	11/30/2023	101020	932.80
		06040650 - 51075 -	Fuel			
241962	3047	365 WORX, INC	TEMP. SERVICE (RITA RIZZO)	12/1/2023	101027	401.28
		06040650 - 52350 -	Temporary Labor			

Department Total : 3,249.88

Moore, OK Purchase Order Claim Register

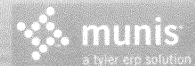

Fund: 06 - General Fund

Check Run : 120723

Department: 068 - Fleet Maintenance

P.O. #	Vendor #	Name	Summary Description	Date	Invoice	Amount
240105	3720	GERARDO ESTRADA	TIRE REPAIRS AND CHANGE OUTS ON SANITATION VEHICL	11/13/2023	100413	100.00
		06040680 - 52354 -	Outsource Labor			
241507	189	O'REILLY AUTOMOTIVE INC	PARTS FOR CITY VEHICLES	11/14/2023	100574	90.30
		06040680 - 51070 -	Parts			
241507	189	O'REILLY AUTOMOTIVE INC	PARTS FOR CITY VEHICLES	11/14/2023	100575	1,876.24
		06040680 - 51070 -	Parts			
241507	189	O'REILLY AUTOMOTIVE INC	PARTS FOR CITY VEHICLES	11/14/2023	100576	18.06
		06040680 - 51070 -	Parts			
240021	1313	CENTRAL OKLAHOMA HOSE, INC	PARTS FOR CITY VEHICLES	11/15/2023	100585	220.33
		06040680 - 51070 -	Parts			
240232	554	BARTON BOLT & SUPPLY, LLC	Nuts, bolts, washers et al	11/15/2023	100590	491.76
		06040680 - 51070 -	Parts			
241200	234	A-WELDORS SUPPLY, INC.	PARTS FOR PUBLIC WORKS FLEET DEPARTMENT	11/13/2023	100597	112.51
		06040680 - 51070 -	Parts			
240022	1525	MOORE OIL & LUBE LLC	OIL CHANGES FOR CITY VEHICLES	11/16/2023	100599	72.95
		06040680 - 52354 -	Outsource Labor			
241374	46	FARRINGTON TRUCK TOWING	TOWING LARGE VEHICLES, SANITATION TRUCKS ET.AL.	11/16/2023	100608	405.00
		06040680 - 52354 -	Outsource Labor			
240104	3567	CH&W LLC	TIRES FOR CITY VEHICLES	11/13/2023	100611	753.60
		06040680 - 51070 -	Parts			
241073	3729	BPB HOLDING CORP	BATTERIES FOR CITY VEHICLES	11/14/2023	100612	463.28
		06040680 - 51070 -	Parts			
241507	189	O'REILLY AUTOMOTIVE INC	PARTS FOR CITY VEHICLES	11/16/2023	100613	93.68
		06040680 - 51070 -	Parts			
241383	908	RUSH TRUCK CENTER OF OKC, INC	PARTS FOR CITY VEHICLES	11/17/2023	100615	78.90
		06040680 - 51070 -	Parts			
242134	3008	PETROCHOICE HOLDINGS, INC.	OILS, LUBRICANTS, FLUIDS, FLOOR DRY ET AL	11/15/2023	100630	1,996.00
		06040680 - 51070 -	Parts			
241507	189	O'REILLY AUTOMOTIVE INC	PARTS FOR CITY VEHICLES	11/17/2023	100631	193.66
		06040680 - 51070 -	Parts			
242108	189	O'REILLY AUTOMOTIVE INC	PARTS FOR CITY VEHICLES	11/17/2023	100632	62.22
		06040680 - 51070 -	Parts			
240023	2025	M & N DEALERSHIPS XII LLC	PARTS FOR CITY VEHICLES	11/17/2023	100633	125.00
		06040680 - 51070 -	Parts			
242108	189	O'REILLY AUTOMOTIVE INC	PARTS FOR CITY VEHICLES	11/17/2023	100634	105.92
		06040680 - 51070 -	Parts			
240024	2025	M & N DEALERSHIPS XII LLC	REPAIRS FOR CITY VEHICLES	11/16/2023	100636	50.34
		06040680 - 52354 -	Outsource Labor			
240677	3624	ONE SOURCE PARTS, LL	PARTS FOR SANITATION TRUCKS	11/17/2023	100777	808.30
		06040680 - 51070 -	Parts			
240024	2025	M & N DEALERSHIPS XII LLC	REPAIRS FOR CITY VEHICLES	11/17/2023	101018	229.53

Moore, OK Purchase Order Claim Register



Fund: 06 - General Fund

Check Run : 120723

Department: 068 - Fleet Maintenance

P.O. #	Vendor #	Name	Summary Description	Date	Invoice	Amount
		06040680 - 52354 -	Outsource Labor			
240421	1872	WRIGHT EXPRESS FSC	CITY WIDE FUEL USAGE	11/30/2023	101020	758.16
		06040680 - 51075 -	Fuel			
240443	194	MYERS BODYWORKS, INC.	WORK, REPAIRS ECT. TO CITY VEHICLES	11/30/2023	101134	740.00
		06040680 - 52354 -	Outsource Labor			
Department Total :						9,845.74

Department: 069 - Building Maintenance

P.O. #	Vendor #	Name	Summary Description	Date	Invoice	Amount
241936	1865	NOVALCO, INC	PARTS FOR DOUBLE SLIDING GLASS DOORS LIBRARY	11/13/2023	100460	187.00
		06040690 - 51070 -	Parts			
240214	72	LOWE'S BUSINESS ACCOUNT	MATERIALS AND SUPPLIES ET AL	11/15/2023	100605	17.08
		06040690 - 51100 -	Building Materials			
240214	72	LOWE'S BUSINESS ACCOUNT	MATERIALS AND SUPPLIES ET AL	11/13/2023	100606	33.22
		06040690 - 51100 -	Building Materials			
242106	3164	AMAZON.COM SALES, INC.	regulators 6 for Bldg Maintenance	11/17/2023	100757	132.54
		06040690 - 51250 -	Misc. Materials & Supplies			
240214	72	LOWE'S BUSINESS ACCOUNT	MATERIALS AND SUPPLIES ET AL	11/16/2023	100841	5.68
		06040690 - 51100 -	Building Materials			
240964	71	LOCKE SUPPLY, INC.	MATERIALS AND SUPPLIES ET AL	11/13/2023	100845	71.39
		06040690 - 51100 -	Building Materials			
240964	71	LOCKE SUPPLY, INC.	MATERIALS AND SUPPLIES ET AL	11/13/2023	100846	6.59
		06040690 - 51100 -	Building Materials			
240964	71	LOCKE SUPPLY, INC.	MATERIALS AND SUPPLIES ET AL	11/14/2023	100847	8.89
		06040690 - 51100 -	Building Materials			
241845	810	EWING IRRIGATION PRODUCTS, INC	MATERIALS AND SUPPLIES ET AL	11/15/2023	100859	80.00
		06040690 - 51100 -	Building Materials			
241845	810	EWING IRRIGATION PRODUCTS, INC	MATERIALS AND SUPPLIES ET AL	11/15/2023	100861	100.00
		06040690 - 51100 -	Building Materials			
240421	1872	WRIGHT EXPRESS FSC	CITY WIDE FUEL USAGE	11/30/2023	101020	333.99
		06040690 - 51075 -	Fuel			
Department Total :						976.38

Department: 070 - Parks & Recreation Admin

P.O. #	Vendor #	Name	Summary Description	Date	Invoice	Amount
240027	3164	AMAZON.COM SALES, INC.	(B) The Station - Special Event supplies	11/14/2023	100485	6.85
		06050700 - 52515 -	Special Events			
240027	3164	AMAZON.COM SALES, INC.	(B) The Station - Special Event supplies	11/13/2023	100486	33.03
		06050700 - 52515 -	Special Events			
240027	3164	AMAZON.COM SALES, INC.	(B) The Station - Special Event supplies	11/16/2023	100703	90.81
		06050700 - 52515 -	Special Events			
240451	103	OKLAHOMA GAS & ELECTRIC	ELECTRICITY	11/22/2023	100905	160.90

Moore, OK Purchase Order Claim Register



Fund: 06 - General Fund

Check Run : 120723

Department: 070 - Parks & Recreation Admin

P.O. #	Vendor #	Name	Summary Description	Date	Invoice	Amount
		06050700 - 52100 -	Electricity			
240495	1734	WALMART COMMUNITY	(B) The Station - Special event supplies	11/30/2023	101054	112.87
		06050700 - 52515 -	Special Events			
240495	1734	WALMART COMMUNITY	(B) The Station - Special event supplies	12/1/2023	101055	12.00
		06050700 - 52515 -	Special Events			
240495	1734	WALMART COMMUNITY	(B) The Station - Special event supplies	11/30/2023	101056	212.46
		06050700 - 52515 -	Special Events			
242200	3064	MOSTELLER MUSIC PRODUCTIONS LLC	The Station-Sound system Christmas Spectacular	12/2/2023	101057	3,900.00
		06050700 - 52515 -	Special Events			
242199	2428	GAME TIME INFLATABLES, LLC	The Station - Inflatables for Christmas events	8/8/2023	101058	630.00
		06050700 - 52515 -	Special Events			
242199	2428	GAME TIME INFLATABLES, LLC	The Station - Inflatables for Christmas events	9/14/2023	101059	550.00
		06050700 - 52515 -	Special Events			
242306	33	CROSSLANDS A & A RENT-ALL	The Station - Restrooms for Christmas Spectacular	12/4/2023	101184	420.00
		06050700 - 52515 -	Special Events			
Department Total :						6,128.92

Department: 071 - Senior Citizen Service

P.O. #	Vendor #	Name	Summary Description	Date	Invoice	Amount
240150	3139	DANIELLE G. MITCHELL	Contract Instructor Chair Yoga	12/2/2023	101019	43.75
		06050710 - 52590 -	Program Instructors			
242297	3571	RICHARD GONZALEZ	Contract Services Bus Driver	12/2/2023	101109	528.75
		06050710 - 52355 -	Contract Services			
Department Total :						572.50

Department: 073 - Parks & Recreation Activities

P.O. #	Vendor #	Name	Summary Description	Date	Invoice	Amount
242072	79	MTM RECOGNITION CORPORATION	The Station -Laser etched plate for league champs	11/14/2023	100540	15.00
		06050730 - 51300 -	Awards (Sport Programs)			
240034	1734	WALMART COMMUNITY	(B) Supplies/snacks for classes/camps	12/5/2023	101193	11.94
		06050730 - 52585 -	Recreation Classes			
Department Total :						26.94

Department: 074 - Parks & Cemetery Maintenance

P.O. #	Vendor #	Name	Summary Description	Date	Invoice	Amount
241891	33	CROSSLANDS A & A RENT-ALL	Scaffolding rental for indoor christmas trees	11/13/2023	100488	190.13
		06050740 - 52200 -	Equipment Rental			
240155	810	EWING IRRIGATION PRODUCTS, INC	(B) Parks Maintenance-parts, materials, supplies	11/17/2023	100720	150.00
		06050740 - 51250 -	Misc. Materials & Supplies			
240011	72	LOWE'S BUSINESS ACCOUNT	(B) Parks Maintenance materials/supplies	11/20/2023	100881	75.55

Moore, OK Purchase Order Claim Register



Fund: 06 - General Fund

Check Run : 120723

Department: 074 - Parks & Cemetery Maintenance

P.O. #	Vendor #	Name	Summary Description	Date	Invoice	Amount
		06050740 - 51250 -	Misc. Materials & Supplies			
240156	1863	SITEONE LANDSCAPE SUPPLY	(B) Parks Maintenance - Chemicals, fertilizer	11/21/2023	100891	1,303.25
		06050740 - 51055 -	Chemicals			
240421	1872	WRIGHT EXPRESS FSC	CITY WIDE FUEL USAGE	11/30/2023	101020	2,491.23
		06050740 - 51075 -	Fuel			
240474	726	EUREKA WATER COMPANY	(B) Park Maint. - Monthly hot/cold cooler rental	11/30/2023	101060	17.49
		06050740 - 52255 -	Minor Equip Maint/Lease			
240473	726	EUREKA WATER COMPANY	(B) Monthly water refills for Park Maintenance	11/6/2023	101061	22.35
		06050740 - 51250 -	Misc. Materials & Supplies			
240473	726	EUREKA WATER COMPANY	(B) Monthly water refills for Park Maintenance	11/20/2023	101062	14.90
		06050740 - 51250 -	Misc. Materials & Supplies			
Department Total :						4,264.90

Department: 075 - Moore Recreation Center

P.O. #	Vendor #	Name	Summary Description	Date	Invoice	Amount
240361	2380	CINTAS CORPORATION #2	(B) Parks & Rec - Contract uniform cleaning	11/15/2023	100543	91.68
		06050750 - 52355 -	Contract Services			
240361	2380	CINTAS CORPORATION #2	(B) Parks & Rec - Contract uniform cleaning	11/15/2023	100544	186.84
		06050750 - 52355 -	Contract Services			
240010	3373	OKLAHOMA FITNESS REPAIR	(B) The Station - Fitness equipment repair	11/15/2023	100701	238.72
		06050750 - 52255 -	Minor Equip Maint/Lease			
240084	1222	BOSS PRINT DESIGN, INC	(B) The Station - Signs, banners, etc.	11/13/2023	100717	215.00
		06050750 - 52000 -	Printing & Publications			
242090	74	MATTOCKS PRINTING CO. LLC	(B) The Station - Guest passes, brochures, etc.	11/14/2023	100718	48.00
		06050750 - 52000 -	Printing & Publications			
242167	1837	KS STATEBANK	CARDIO AND STRENGTH TRAINING FITNESS EQUIPMENT	11/15/2023	100756	48,955.97
		06050750 - 52565 -	Fitness Equipment Lease			
242007	2075	GLOBAL EQUIPMENT CO, INC	Replace broken H2O fountain at FM	11/17/2023	100886	1,041.99
		06050750 - 52255 -	Minor Equip Maint/Lease			
240451	103	OKLAHOMA GAS & ELECTRIC	ELECTRICITY	11/22/2023	100905	6,121.23
		06050750 - 52100 -	Electricity			
240412	1734	WALMART COMMUNITY	(B) The Station - Supplies for fitness classes	11/30/2023	101053	19.94
		06050750 - 52585 -	Recreation Classes			
242273	2053	COURTNEY AINSWORTH	Group Ex Instructor 12.2.23	12/2/2023	101113	475.00
		06050750 - 52590 -	Program Instructors			
242291	3978	IRMA LETICIA ARAGON	Group Ex Instructor 12.2.23	12/2/2023	101114	75.00
		06050750 - 52590 -	Program Instructors			
242275	2207	BERRY, TAMARA R	Group Ex Instructor 12.2.23	12/2/2023	101115	50.00
		06050750 - 52590 -	Program Instructors			
242274	2140	HRISTINA MILCHEVA BROWN	Group Ex Instructor 12.2.23	12/2/2023	101116	25.00

Moore, OK Purchase Order Claim Register



Fund: 06 - General Fund

Check Run : 120723

Department: 075 - Moore Recreation Center

P.O. #	Vendor #	Name	Summary Description	Date	Invoice	Amount
		06050750 - 52590 -	Program Instructors			
242270	2033	IRINA S CHEVIS	Group Ex Instructor 12.2.23	12/2/2023	101117	50.00
		06050750 - 52590 -	Program Instructors			
242278	2415	DANNA C FOWBLE	Group Ex Instructor 12.2.23	12/2/2023	101118	75.00
		06050750 - 52590 -	Program Instructors			
242292	3979	JOSIE GARRARD	Group Ex Instructor 12.2.23	12/2/2023	101119	25.00
		06050750 - 52590 -	Program Instructors			
242271	2045	SHERRI R KING	Group Ex Instructor 12.2.23	12/2/2023	101120	175.00
		06050750 - 52590 -	Program Instructors			
242282	2865	GRACIELA LOPEZ-HERNANDEZ	Group Ex Instructor 12.2.23	12/2/2023	101121	50.00
		06050750 - 52590 -	Program Instructors			
242279	2673	NATALLIA POTTER BUCHANKOVA	Group Ex Instructor 12.2.23	12/2/2023	101122	125.00
		06050750 - 52590 -	Program Instructors			
242283	2879	DESTINY OLIGANGA	Group Ex Instructor 12.2.23	12/2/2023	101123	25.00
		06050750 - 52590 -	Program Instructors			
242289	3642	JENNA E SEELEY	Group Ex Instructor 12.2.23	12/2/2023	101124	125.00
		06050750 - 52590 -	Program Instructors			
242277	2404	KAZUMI SMITH	Group Ex Instructor 12.2.23	12/2/2023	101125	250.00
		06050750 - 52590 -	Program Instructors			
242272	2046	ROBERT L SUMMERS	Group Ex Instructor 12.2.23	12/2/2023	101126	250.00
		06050750 - 52590 -	Program Instructors			
242290	3892	KRISTI AILEEN WALKER	Group Ex Instructor 12.2.23	12/2/2023	101127	75.00
		06050750 - 52590 -	Program Instructors			
242280	2783	GLORIA WRIGHT	Group Ex Instructor 12.2.23	12/2/2023	101128	100.00
		06050750 - 52590 -	Program Instructors			
242281	2783	GLORIA WRIGHT	Group Ex Instructor 11.18.23	11/18/2023	101129	25.00
		06050750 - 52590 -	Program Instructors			
242298	4017	SEAN TYLER COWDEN	Personal Training 10.21.23	10/21/2023	101130	25.00
		06050750 - 52590 -	Program Instructors			
242299	4017	SEAN TYLER COWDEN	Personal Training 11.4.23	11/4/2023	101131	100.00
		06050750 - 52590 -	Program Instructors			
242300	4017	SEAN TYLER COWDEN	Personal Training 11.18.23	11/18/2023	101132	25.00
		06050750 - 52590 -	Program Instructors			
242285	2963	SHERRI L EDGE	Group Ex Instructor 11.18.23	12/2/2023	101138	25.00
		06050750 - 52590 -	Program Instructors			
242304	4017	SEAN TYLER COWDEN	Personal Training 12.2.23	12/2/2023	101144	25.00
		06050750 - 52590 -	Program Instructors			
242307	1976	ARC PYROTECHNICS, INC	2023 Christmas Spectacular Fireworks	12/4/2023	101185	9,000.00
		06050750 - 52950 -	Christmas Spectacular			

Department Total : 68,094.37

Department: 077 - Library

P.O. #	Vendor #	Name	Summary Description	Date	Invoice	Amount
242106	3164	AMAZON.COM SALES, INC.	regulators 6 for Bldg Maintenance	11/17/2023	100757	88.36

Moore, OK Purchase Order Claim Register



Fund: 06 - General Fund

Check Run : 120723

Department: 077 - Library

P.O. #	Vendor #	Name	Summary Description	Date	Invoice	Amount
		06050770 - 52260 -	Building Maintenance/Repair			
Department Total :						88.36

Department: 080 - Community Development/Planning

P.O. #	Vendor #	Name	Summary Description	Date	Invoice	Amount
240894	2885	GARVER, LLC	Engineering consulting	11/11/2023	100989	2,226.00
		06060800 - 52360 -	Professional Services			
241338	3971	UNDERGROUND VAULTS & STORAGE, INC	Recurring monthly expense off site storage	10/31/2023	100991	66.56
		06060800 - 52545 -	Misc Services & Charges			
240871	3613	CIVIL & ENVIRONMENTAL CONSULTANTS, INC.	City of Moore On - Call Engineering	11/13/2023	100992	601.20
		06060800 - 52360 -	Professional Services			
240897	1697	MESHEK & ASSOCIATES, PLC	Moore On-Call Engineering Services	11/1/2023	100993	4,153.75
		06060800 - 52360 -	Professional Services			
240852	2355	ABSOLUTE DATA SHREDDING	Recurring Expense for Recycle Events FY 23-24	10/31/2023	100994	750.00
		06060800 - 52450 -	Stormwater Management			
240421	1872	WRIGHT EXPRESS FSC	CITY WIDE FUEL USAGE	11/30/2023	101020	82.63
		06060800 - 51075 -	Fuel			
242253	3371	UNITED ELECTRONIC RECYCLING LLC	Recycling Event 10/28/23	11/16/2023	101152	2,350.00
		06060800 - 52450 -	Stormwater Management			
Department Total :						10,230.14

Department: 081 - Inspections

P.O. #	Vendor #	Name	Summary Description	Date	Invoice	Amount
240421	1872	WRIGHT EXPRESS FSC	CITY WIDE FUEL USAGE	11/30/2023	101020	472.30
		06060810 - 51075 -	Fuel			
Department Total :						472.30

Department: 082 - Code Enforcement

P.O. #	Vendor #	Name	Summary Description	Date	Invoice	Amount
242179	4054	PLAINS MOVING, LLC	Abatements	11/28/2023	101005	258.14
		06060820 - 52355 -	Contract Services			
242179	4054	PLAINS MOVING, LLC	Abatements	11/28/2023	101006	258.14
		06060820 - 52355 -	Contract Services			
242179	4054	PLAINS MOVING, LLC	Abatements	11/28/2023	101007	830.50
		06060820 - 52355 -	Contract Services			
242179	4054	PLAINS MOVING, LLC	Abatements	11/28/2023	101008	538.14
		06060820 - 52355 -	Contract Services			
240421	1872	WRIGHT EXPRESS FSC	CITY WIDE FUEL USAGE	11/30/2023	101020	300.03
		06060820 - 51075 -	Fuel			
Department Total :						2,184.95
Fund Total :						277,599.75

Moore, OK Purchase Order Claim Register



Fund: 08 - Special Revenue Fund

Check Run : 120723

Department: 214 - CDBG Entitlement

P.O. #	Vendor #	Name	Summary Description	Date	Invoice	Amount
241696	853	AGING SERVICES, INC.	2023 CDBG Public Service - Senior Meals	11/16/2023	101028	2,595.00
	08042140 - 55117 -		CDBG 2023			
Department Total :						2,595.00

Department: 220 - Transportation Impact Fees

P.O. #	Vendor #	Name	Summary Description	Date	Invoice	Amount
223184	2895	FREESE AND NICHOLS, INC	PROFESSIONAL ENGINEERING DESIGN SERVS-	11/14/2023	101034	5,523.26
	08032200 - 55425 -		Transportation Impact Projects			
Department Total :						5,523.26
Fund Total :						8,118.26

Moore, OK Purchase Order Claim Register



Fund: 09 - Debt Service Fund

Check Run : 120723

Department: 504 - 2014 Park GO Bonds

P.O. #	Vendor #	Name	Summary Description	Date	Invoice	Amount
242213	666	BANK OF OKLAHOMA 09085040 - 54000 -	CMOKGOBS2014 Debt Service Bond Principal	11/16/2023	100921	825,000.00
242213	666	BANK OF OKLAHOMA 09085040 - 54005 -	CMOKGOBS2014 Debt Service Bond Interest	11/16/2023	100921	35,475.00
242213	666	BANK OF OKLAHOMA 09085040 - 54165 -	CMOKGOBS2014 Debt Service Paying Agent	11/16/2023	100921	125.00
Department Total :						860,600.00

Department: 531 - 2019 GO Street/Drainage

P.O. #	Vendor #	Name	Summary Description	Date	Invoice	Amount
242212	666	BANK OF OKLAHOMA 09085310 - 54000 -	MOOREGO2019 Bond Principal	11/16/2023	100920	950,000.00
242212	666	BANK OF OKLAHOMA 09085310 - 54005 -	MOOREGO2019 Bond Interest	11/16/2023	100920	82,531.25
242212	666	BANK OF OKLAHOMA 09085310 - 54165 -	MOOREGO2019 Paying Agent	11/16/2023	100920	125.00
Department Total :						1,032,656.25
Fund Total :						1,893,256.25

Moore, OK Purchase Order Claim Register



Fund: 11 - 1/8 Cent Sales Tax

Check Run : 120723

Department: 350 - 1/8 ST Water/SW/Drainage

P.O. #	Vendor #	Name	Summary Description	Date	Invoice	Amount
241174	934	VEOLIA WATER NORTH AMERICA 11043500 - 53075 -	REPAIR & MAINTENANCE (costs in excess) Water Systems Improvements	10/23/2023	100978	40,424.12
Department Total :						40,424.12
Fund Total :						40,424.12

Moore, OK Purchase Order Claim Register



Fund: 12 - 1/2 Cent Sales Tax

Check Run : 120723

Department: 582 - Residential Streets

P.O. #	Vendor #	Name	Summary Description	Date	Invoice	Amount
241317	4032	BLACKBIRD ENVIRONMENTAL, LLC 12035820 - 53160 -	SENDERA LAKES CHANNEL MAINTENANCE Res Str Construct - Ward 3	11/13/2023	100416	3,319.65
Department Total :						3,319.65
Fund Total :						3,319.65

Moore, OK Purchase Order Claim Register



Fund: 13 - 1/4 Cent Sales Tax

Check Run : 120723

Department: 611 - Central Park

P.O. #	Vendor #	Name	Summary Description	Date	Invoice	Amount
223614	3619	NABHOLZ CONSTRUCTION CORPORATION 13056110 - 54375 -	CONSTRUCTION MGMT AT RISK CONTRACT (STATION) Park Improvements	10/20/2023	101014	528,745.29
Department Total :						528,745.29
Fund Total :						528,745.29

**CITY OF MOORE
ORDINANCE NO. 1038.23**

AN ORDINANCE AMENDING PART 5, CHAPTER 1, ARTICLE B, SECTION 5-120; ARTICLE C, SECTION 5-136 THROUGH 5-141; AND ARTICLE D, SECTION 5-150 THROUGH 5-163; AMENDED AND MODIFIED GENERAL REQUIREMENTS FOR THE BUILDING REGULATIONS AND CONSTRUCTION CODES GOVERNING THE DESIGN, INSTALLATION AND CONSTRUCTION WITHIN MOORE, OKLAHOMA; PROVIDING FOR SEVERABILITY; PROVIDING FOR REPEALER.

BE IT ORDAINED BY THE CITY COUNCIL OF THE CITY OF MOORE, OKLAHOMA THAT PART 5, CHAPTER 1, ARTICLE B, SECTION 5-120; ARTICLE C, SECTION 5-136 THROUGH 5-141; AND ARTICLE D, SECTION 5-150 THROUGH 5-163 ARE HEREBY AMENDED TO READ AS FOLLOWS:

PART 5 BUILDING REGULATIONS AND CONSTRUCTION CODES

CHAPTER 5-1 GENERAL, LICENSES AND FEES, PERMITS, BOND AND INSURANCE
CHAPTER 5-2 BUILDING CODE AND REGULATIONS
CHAPTER 5-3 PLUMBING CODE AND REGULATIONS
CHAPTER 5-4 ELECTRIC CODE
CHAPTER 5-5 MECHANICAL CODE
CHAPTER 5-6 GAS CODE AND PIPELINES
CHAPTER 5-7 FAIR HOUSING
CHAPTER 5-8 OUTDOOR LIGHT FIXTURES
CHAPTER 5-9 FUEL GAS CODE
CHAPTER 5-10 ROOFING CONTRACTORS
CHAPTER 5-11 STORM SHELTERS
CHAPTER 5-12 EXISTING BUILDING CODE

CHAPTER 5-1 GENERAL, LICENSES AND FEES, PERMITS, BOND AND INSURANCE

ARTICLE 5-1A LICENSES AND FEES, PERMITS, BOND AND INSURANCE
ARTICLE 5-1B PERMITS AND INSPECTIONS
ARTICLE 5-1C OTHER REGULATIONS
ARTICLE 5-1D BOARD OF APPEALS

ARTICLE 5-1B PERMITS AND INSPECTIONS

Sec 5-111 Building Permits
Sec 5-112 Expiration Of Permits
Sec 5-113 Plumbing, Electrical, Mechanical And Other Permits
Sec 5-114 Applicability Of Permit Requirements To Federal And State Agencies
Sec 5-115 Schedule Of Permit And Inspection Fees
Sec 5-116 Prepayment For Fees Required
Sec 5-117 Plans, Application
Sec 5-118 Display Of Permits

Sec 5-119 Revocation

Sec 5-120 Exceptions From Permit Requirements

Sec 5-120 Exceptions From Permit Requirements

~~Ordinary repairs of buildings or structures, or the plumbing drainage, or piping thereof, the cost of which shall not exceed \$500.00, may be made without notice to the city, but such repairs shall not be construed to include the removal of any stone, concrete or brick wall, or any portion thereof; the removal or cutting of any beams or supports, or the removal, change or closing of any stairway, or opening in the exterior wall; the alteration or removal of any house sewer, or drainage system, or soil waste or vent pipe or water or gas service line; or repairs or alterations of light or power wiring.~~

(Prior Code, § 5-55, in part; Code 1999, § 5-130)

ARTICLE 5-1C OTHER REGULATIONS

Sec 5-131 Right To Enforce And Stop Construction

Sec 5-132 Cases Of Urgency

Sec 5-133 Power To Make Rulings

Sec 5-134 Power To Call Upon Police Or Fire Department

Sec 5-135 Power To Enter

Sec 5-136 Work without a permit

Sec 5-137 Unauthorized cover up

Sec 5-1368 Penalty

Sec 5-1379 Relief In The Courts

Sec 5-13840 Effect Of Violation By Corporate Officers And Agents

Sec 5-13941 Conviction To Be Deemed Cause For Revocation Of Licenses, Certificates

Sec 5-136 Work without a permit

- (a) Investigation. Whenever work for which a permit is required by this code has been commenced without first obtaining a permit, a special investigation shall be made before a permit may be issued for such work.
- (b) Fee. An investigation fee, in addition to the permit fee, shall be collected whether or not a permit is subsequently issued. The investigation fee shall be equal to the amount of the permit fee required by this code or the city fee schedule as applicable. The payment of such investigation fee shall not exempt the applicant from compliance with all other provisions of either this code or the technical codes nor from penalty prescribed by law.

Sec 5-137 Unauthorized cover up

Any work concealed without first obtaining the required inspection is unauthorized. An additional unauthorized covering fee shall be added when work is concealed from it's proper inspection. In addition to the permit or any other fee, the unauthorized covering fee shall be collected, prior to any construction activity to continue. The unauthorized covering fee amount shall be listed in the adopted city fee schedule. The payment of such fee shall not exempt the applicant from compliance with all other provisions of either this code or the construction codes, nor from a penalty prescribed by law.

Sec 5-1368 Penalty

Any person who shall engage in any business, trade, or vocation for which a license, permit, certificate, or registration is required by this part, without having a valid license, permit, certificate, or certificate of registration as required, or who shall fail to do anything required by this part or by any code adopted by this part, or who shall otherwise violate any provision of this part or of any code adopted by this part, or who shall violate any lawful regulation or order made by any of the officers provided for in this part, shall be guilty of an offense, and, upon conviction thereof, shall be subject to punishment as provided in section 1-108.

(Prior Code, § 5-5; Code 1999, § 5-146)

Sec 5-1379 Relief In The Courts

No penalty imposed by and pursuant to this part shall interfere with the right of the city also to apply to the proper courts of the state for a mandamus, an injunction, or other appropriate action against the person violating this part.

(Prior Code, § 5-6; Code 1999, § 5-147)

Sec 5-13840 Effect Of Violation By Corporate Officers And Agents

Violation of any of the terms or provisions of this part by any corporation or association shall subject the officers and agents in charge of the business of such corporation or association to the penalty provided in this part.

(Prior Code, § 5-7; Code 1999, § 5-148)

Sec 5-13941 Conviction To Be Deemed Cause For Revocation Of Licenses, Certificates

Conviction under the provisions of this part shall be deemed just cause for the revocation of any certificate or license which a person may have or hold under the provisions of this part.

ARTICLE 5-1D BOARD OF APPEALS

Sec 5-150 General
Sec 5-151 Limitations of authority
Sec 5-152 Application for appeal
Sec 5-153 Membership of board
Sec 5-154 Qualifications
Sec 5-155 Alternative members
Sec 5-156 Chairman
Sec 5-157 Disqualification of member
Sec 5-158 Secretary
Sec 5-159 Notice of meeting
Sec 5-160 Open hearing
Sec 5-161 Procedure
Sec 5-162 Postponed hearing
Sec 5-163 Board decision
Sec 5-164 Court review

Sec 5-150 General

In order to hear and decide appeals of orders, decisions or determinations made by the building official relative to the application and interpretation of the construction codes, there shall be and is hereby created a board of appeals. The board of appeals shall be appointed by City Council.

Sec 5-151 Limitations on authority

An application for appeal shall be based on a claim that the true intent of the construction codes or the rules legally adopted thereunder have been incorrectly interpreted, the provision of the construction codes do not fully apply or an equally good or better form of construction is proposed. The board shall not have the authority to waive requirements of the construction codes.

Sec 5-152 Application for appeal

Any person shall have the right to appeal a decision of the code official to the board of appeals. An application for appeal shall be based on a claim that the true intent of this code or rules legally adopted thereunder have been incorrectly interpreted, the provisions of this code do not fully apply, or an equally good or better form of construction is proposed. The application shall be filed on a form obtained from the code official within 20 days after the notice was served.

Sec 5-153 Membership of board

The board of appeals shall consist of five members appointed by the-mayor and confirmed by the city council as follows: Positions 1, 3 and 5 for two years and positions 2 and 4 for three years. Thereafter, each new member shall serve for 3 years or until a successor has been appointed. The appointive members may be removed for cause. Vacancies shall be filled by appointment for the unexpired term. All members of the board cannot be with a common employer or a joint business partnership. All members must be from a separate entity of business.

Sec 5-154 Qualifications

The board of appeals shall consist of five individuals, one from each of the following professions or disciplines:

- (a) Registered Oklahoma design professional who is a registered architect for 3 consecutive years; or a builder or superintendent of building construction with not less than 10 years' experience, 5 years of which shall have been responsible charge of work.
- (b) Registered Oklahoma design professional with structural engineering or architectural with no less than 3 years of design or project management experience.
- (c) Registered Oklahoma design professional with mechanical and plumbing engineering for 3 consecutive years; or an Oklahoma mechanical and plumbing contractor with not less than 10 years' experience, 5 years of which shall have been in responsible charge of work in the State of Oklahoma.
- (d) Registered Oklahoma design professional with electrical engineering for 3 consecutive years, or an Oklahoma electrical contractor with not less than 10 years' experience, 5 years of which shall have been in responsible charge of work in the State of Oklahoma.
- (e) Registered Oklahoma design professional with fire protection engineering for 3 consecutive years; or an Oklahoma fire protection contractor with not less than 10 years' experience, 5 years of which shall have been in responsible charge of work in the State of Oklahoma.

Sec 5-155 Alternative Members

The mayor and confirmed by the city council shall appoint two alternate members who shall be called by the board chairman to hear appeals during the absence or disqualification of a member. Alternate members shall possess the qualifications required for board membership and shall be appointed for 3 years or until a successor has been appointed. All members of the board cannot be with a common employer or a joint business partnership. All members must be from a separate entity of business.

Sec 5-156 Chairman

The Board shall annually select one of its members to serve as chairman.

Sec 5-157 Disqualification of member

A member shall not hear an appeal in which that member has any personal, professional or financial interest.

Sec 5-158 Secretary

The chief administrative officer shall designate a qualified clerk to serve as secretary to the board. The secretary shall file a detailed record of all proceedings in the office of the city clerk

Sec 5-159 Notice of meeting

The board shall meet upon notice from the chairman, within 10 days of the filing of an appeal or at stated periodic meetings.

Sec 5-160 Open hearing

Hearings before the board shall be open to the public. The appellant, the appellant's representative, the code official and any person whose interest are affected shall be given an opportunity to be heard.

Sec 5-161 Procedure

The board shall adopt and make available to the public through the secretary procedures under which a hearing will be conducted. The procedures shall not require compliance with strict rules of evidence but shall mandate that only relevant information be received.

Sec 5-162 Postponed hearing

When five members are not present to hear an appeal, either the appellant or the appellant's representative shall have the right to request a postponement of the hearing.

Sec 5-163 Board decision

The board shall modify or reverse the decision of the code official by a concurring vote of three members.

- (a) Resolution. The decision of the board shall be by resolution. Certified copies shall be furnished to the appellant and to the code official.
- (b) Administration. The code official shall take immediate action in accordance with the decision of the board.

Severability. If any of the provisions of this ordinance are determined to be unconstitutional or unlawful by any court of competent jurisdiction, the remainder shall be severable and unaffected.

Repealer. Any ordinance or parts thereof in conflict with this section are hereby repealed.

PASSED AND APPROVED THIS 18TH DAY OF DECEMBER, 2023.

MELISSA HUNT, Vice-Mayor

ATTEST: *(Seal)*

VANESSA KEMP, City Clerk

APPROVED AS TO FORM AND LEGALITY:

Brian K. Miller, City Attorney

**CITY OF MOORE
ORDINANCE NO. 1039.23**

AN ORDINANCE AMENDING PART 5, CHAPTER 2, ARTICLE A, SECTIONS 5-201, 5-202, 5-204, 5-206, 5-207 AND 5-210; AND ARTICLE D, SECTIONS 5-251 THROUGH 5-253; ADOPTING THE 2018 INTERNATIONAL BUILDING CODE AND THE 2018 INTERNATIONAL RESIDENTIAL CODE AS AMENDED AND MODIFIED BY THE OKLAHOMA UNIFORM BUILDING CODE COMMISSION AND ADOPTING LOCAL AMENDMENTS TO SAID CODE; ESTABLISHING MINIMUM REGULATIONS GOVERNING THE DESIGN, INSTALLATION AND CONSTRUCTION OF BUILDINGS AND ONE-TO-TWO FAMILY DWELLINGS WITHIN MOORE, OKLAHOMA; PROVIDING FOR SEVERABILITY; PROVIDING FOR REPEALER.

BE IT ORDAINED BY THE CITY COUNCIL OF THE CITY OF MOORE, OKLAHOMA THAT PART 5, CHAPTER 2, ARTICLE A, SECTIONS 5-201, 5-202, 5-204, 5-206, 5-207 AND 5-210; AND ARTICLE D, SECTIONS 5-251 THROUGH 5-253 ARE HEREBY AMENDED TO READ AS FOLLOWS:

CHAPTER 5-2 BUILDING CODE AND REGULATIONS

ARTICLE 5-2A BUILDING AND RESIDENTIAL CODE

ARTICLE 5-2B MOVING AND RELOCATING BUILDINGS

ARTICLE 5-2C SIGN CONTRACTORS

ARTICLE 5-2D ONE-TO-TWO FAMILY AWNINGS, CARPORTS AND PATIO COVERS

ARTICLE 5-2E FENCES

ARTICLE 5-2F SWIMMING POOLS

ARTICLE 5-2A BUILDING AND RESIDENTIAL CODE

Sec 5-201 Adoption Of The International Building Code

Sec 5-202 Amendments Of The International Building Code

Sec 5-203 Provisions Declared To Be Minimum Requirements

Sec 5-204 Adoption Of The ~~2015~~ International Residential Code, ~~As Amended And Modified By The State Uniform Building Code Commission Pursuant To 59 OS Section 1000.23~~

Sec 5-205 Smoke Detectors Required In Apartment Dwellings

Sec 5-206 Adoption Of Standard Specifications For The Construction Of Water And Sewer

Sec 5-207 Adoption Of Paving, Sidewalk, And Driveway Specifications

Sec 5-208 Enforcement

Sec 5-209 Liquefied Petroleum Gas Code Adopted, Penalty

~~Sec 5-210 Private Water Wells Prohibited~~

Sec 5-211 House, Building Numbering System

Sec 5-212 Building Standards For Construction Of Residential Dwellings Within Tornado Damage Area

Sec 5-201 Adoption of the International Building Code

There is hereby adopted that certain code known as the International Building Code ~~2015~~ 2018 edition, as amended and modified by the state Oklahoma uniform building code commission

pursuant to 59 O.S. § 1000.23, as the building code of the city for the control of buildings and structures as herein provided, referred to herein as the “IBC” or "building code." Each and all of the regulations, provisions, penalties, conditions and terms of the building code are hereby referred to, adopted and made a part hereof as if fully set out in this Code, with the additions, insertions, deletions and changes, if any, prescribed herein. Not less than one copy of this code is on file in the office of the clerk.

State Law reference— Adoption by reference, 11 O.S. § 14-107.

Sec 5-202 Amendments of the International Building Code

(a) ~~A~~. The following additions, amendments or deletions are made to the building code adopted herein:

(1) Section 101.1. Insert: [The City of Moore, Oklahoma.]

(2) Section 101.2.1 Insert: [The provisions in Appendix C, H, I, and J are hereby adopted and considered a part of this Code.]

(3) Section 101.4 Amend to read: [The other codes listed in Sections 101.4.1 through 101.4.8 and referenced elsewhere in this code, when specifically adopted, shall be considered part of the requirements of this code to the prescribed extent of each such reference. Whenever amendments have been adopted to the referenced codes and standards, each reference to said code and standard shall be considered to reference the amendments as well. Any reference to NFPA 70 or the Electrical Code shall mean the National Electrical Code as adopted.]

(4) Section 101.4.3 Amend to read: [The provisions of the International Plumbing Code shall apply to the installation, alteration, repair and replacement of plumbing systems, including equipment, appliances, fixtures, fittings and appurtenances and where connected to a water or sewage system and all aspects of a medical gas system. The provisions of the International Private Sewage Disposal systems shall conform to the regulations set forth in Title 252, Chapter 641 of the Oklahoma Administrative Code.]

(5) Section 101.4.8 Insert: [101.4.8 Electrical. The provisions of the National Electrical Code – NFPA 70 shall apply to the installation of electrical systems, including alterations, repairs, replacement, equipment, appliances, fixtures, fittings and appurtenances thereto.]

(6) Section 103.1 Delete: Department of Building Safety; Replace and Insert: [City of Moore’s Community Development Department.]

(7) Section 104.10.1; delete section

(8) Section 105.2; Number 1 Amend to read: [1. One-story detached accessory structures used as playhouses and similar uses, provided the building has no electric, plumbing

mechanical or gas connections.]

(9) Section 105.2; Number 4 Amend to read: [Retaining Wall]

(10) Section 105.2; Delete: Number 2, 3, and 6

~~Section 107.3.4.1. Insert at the end of section: Exception: Plans for additions of less than 500 square feet to existing commercial structures or for any commercial remodel where the structural design of the building is not changed shall not be required to be prepared by a registered professional architect or engineer licensed by the state.~~

~~Section 109.2. Refer: Those certain fees adopted by the city on September 7, 1997, and as they may be amended from time by motion or resolution of the city council.~~

(11) Section 109.7 Insert: [109.7 Re-inspection Fee. A fee as established by city council resolution may be charged when:

- a. 1. The inspection called for is not ready when the inspector arrives;
- b. 2. No building address or permit card is clearly posted;
- c. 3. City approved plans are not on the job site available to the inspector;
- d. 4. The building is locked or work otherwise not available for inspection when called;
- e. 5. The job site is red-tagged twice for the same item;
- f. 6. The original red tag has been removed from the job site.
- g. 7. Failure to maintain erosion control, trash control or tree protection.
- h. 8. A second inspection is requested or required due to the lack of proper installation, construction or materials.

Any re-inspection fees assessed shall be paid before any more inspections are made on that job site.]

(12) Section 110.3.5 delete and amend to read: [110.3.5 Insulation inspection. Insulation inspections shall be made after framing, mechanical, electrical, fuel/gas and plumbing rough-in inspections are approved and before the installation of any wall coverings.]

(13) Section 111.1 remove the word “and” in the first sentence and replace it with the word: [or].

(14) Section 111.5 Amend: [111.5 Warrant of Completion. A warrant of completion shall be issued by the building official for a building or structure shell only when a finish-out or remodel is pending. Issuance of a warrant of completion does not constitute a Certificate of Occupancy. Issuance of a warrant shall not be construed as an approval of a violation of the provisions of this code or of other ordinances of the jurisdiction.]

~~Section 113.1. Delete: "Board of Appeals." Insert: at end of second sentence: The appeals procedure shall be as specified in article B, sections 12-123 et seq., of the city's zoning ordinance.~~

(15) Section 113.1, 113.2 and 113.3 Delete sections and Insert: [Section 113 Board of Appeals. The appeals procedure shall be specified in Article 5-1D of the Municipal Code.]

(16) Section 114.4. Delete entire section and insert: Penalties shall be set forth in section 1-108 of the City Code.

(17) Section 202, add and amend "Flex Space" and "Repair Garage":

a. [FLEX SPACE. A room or space that can fulfill multiple purposes and does not define the actual use of a room or space. A flexible area that varies in both shape and function. Flex space or the use of other terms such as bonus room/area, additional space, or any other terminology that does not define the exact use shall be constructed to the most restrictive zoning use allowed by the adopted Land Development Code for the City of Moore. Bathrooms, kitchens, or any other plumbing fixture, piping or any accessible plumbing system is not allowed within this room/space, except fire sprinkler protection system only.]

b. [REPAIR GARAGE. A building, structure or portion thereof used for servicing or repairing motor vehicles. This occupancy shall also include garages involved in minor repair, modification, and servicing of motor vehicles for items such as lube changes, inspections, windshield repair or replacement, shocks, minor part replacement and other such minor repairs.]

(18) Section 303.1.3 Insert at the end of the section: [except when applying the assembly requirements of Chapters 10 and 11.]

(19) Section 403.3.2, Delete text: "420"; Replace and Insert: [120 feet].

(20) Section 506.2 Delete Section

(21) Section 602.1.1 Amend a paragraph at the end to read: [Where a building contains more than one distinct type of construction, the building shall comply with the most

restrictive area, height, and stories, for the lesser type of construction or be separated by fire walls.]

(22) Section 703.7 Amend item 1 and 3 to read:

1. [Be located continuously and within 15 feet (4,572 mm) of the end of each wall and at intervals not exceeding 30 feet (9,144 mm) measured horizontally along the wall or partition.]
3. [Lettering shall be a minimum of 36" from the bottom of the wall and 36" from the top or peak of the wall.]

(23) Section 706.12 Amend to read: [706.12 Marking and identification. A two story or larger building shall have a four foot long and a four-inch-wide reflective strip shall permanently adhere or anchor to the exterior wall facing the fire apparatus lane, public street, private street and parking aisle to identify the location of a fire wall. The placement must begin with a minimum of two feet under the eave or top of the parapet wall and a maximum of eight feet under the eave or top of the parapet.]

(24) Section 708.4.2 Insert sentence in the middle of section of exception number 1 to read: [Portions of buildings containing concealed spaces filled with noncombustible insulation as permitted for sprinkler omission shall not apply to this exception for draftstopping.]

(25) Section 718.3 Insert a sentence at the end of the exceptions to read: [and provided that in combustible construction, sprinkler protection is provided in the floor space.]

(26) Section 718.4 Insert a sentence at the end of the exception: [and provided that in combustible construction, sprinkler protection is provided in the attic space.]

(27) Section 903.1.1 Delete: "instead of"; replace and insert: [in addition to] and delete: "and"; replace and insert: [or as].

(28) Section 903.2.9 Amend an additional condition to read: [6. A Group S-1 fire area used for the self-service storage facility exceeds 2,500 square feet (232 m²).]

(29) Section 903.3.1.2.3 Delete first sentence and replace to read: [Sprinkler protection is required in attached garages and in the following attic spaces:]

(30) Section 903.3.1.2.3 Delete item number 3 and replace to read: [Attic spaces of buildings that are two or more stories in height above grade plane or above the lowest level of fire department vehicle access.] and in item number 4 add the following within the middle of the sentence: [or 3].

(31) Section 903.3.1.4 Amend the following to read: [903.3.1.4 Freeze protection. Freeze protection systems for automatic fire sprinkler systems shall be in accordance with

the requirements of the applicable referenced NFPA standard and this section.]

- (32) Section 903.3.1.4.1 Amend the following to read: [903.3.1.4.1 Attics. Only dry-pipe reaction, or listed antifreeze automatic fire sprinkler systems shall be allowed to protect attic spaces.]

Exception: Wet-pipe fire sprinkler systems shall be allowed to protect non-ventilated attic spaces where:

1. The attic sprinklers are supplied by a separate floor control valve assembly to allow ease of draining the attic system without impairing sprinklers throughout the rest of the building, and
2. Adequate heat shall be provided for freeze protection as per the applicable referenced NFPA standard, and
3. The attic space is a part of the building's thermal, or heat, envelope, such that insulation is provided at the roof deck, rather than at the ceiling level.]

- (33) Section 903.3.1.4.2 Amend the following to read: [903.3.1.4.2 Heat trace/insulation. Heat trace/insulation shall only be allowed where approved by the fire code official for small sections that don't exceed five feet of large diameter water-filled pipe.]

- (34) Section 903.4.2 Amend a second paragraph to read: [The alarm device required on the exterior of the building shall be a weatherproof horn/strobe notification appliance with a minimum 75 effective intensity strobe rating, installed as close as practicable to the fire department connection.]

- (35) Section 905.4, change items 1, 2, 3 and 5; and amend item 7: Item 1 – Delete: “interior”; Item 2 – Delete all of the exception; Item 3 – Delete all of the exception; Item 5 – Insert: [each standpipe shall be provided with a two-way] and delete: “shall be” and “interior”; Item 7 – Amend the following to read: [When required by this Chapter, standpipe connections shall be placed adjacent to all required exits to the structure and at two hundred feet (200') intervals along major corridors thereafter, or as otherwise approved by the fire code official.]

- (36) Section 907.4.2.7 amend to read as follows: [907.4.2.7 Type. Manual alarm initiating devices shall be an approved double action type.]

- (37) Section 910.2.3 amend to read as follows: [910.2.3 Group H. Buildings and portions thereof used as a Group H occupancy as follows:

1. In occupancies classified as Group H-2 or H-3, any of which are more than 15,000 square feet (1394 m²) in single floor area.

Exception: Buildings of noncombustible construction containing only

noncombustible materials.

2. In areas of buildings in Group H used for storing Class 2, 3, and 4 liquid and solid oxidizers, Class 1 and unclassified detonable organic peroxides, Class 3 and 4 unstable (reactive) materials, or Class 2 or 3 water-reactive materials as required for a high-hazard commodity classification.

Exception: Buildings of noncombustible construction containing only noncombustible materials.]

- (38) Section 913.2.1.1 amend to read as follows: [913.2.1.1 Fire Pump Room Access. When located on the ground level at an exterior wall, the fire pump room shall be provided with an exterior fire department access door that is not less than 3 ft. in width and 6 ft. – 8 in. in height, regardless of any interior doors that are provided. A knox box shall be provided at this door, as required by IFC Section 506.1.

Exception: When it is necessary to locate the fire pump room on other levels or not at an exterior wall, the corridor leading to the fire pump room access from the exterior of the building shall be provided with equivalent fire resistance as that required for the pump room, or as approved by the fire code official. Access keys shall be provided in the knox box as required by IFC Section 506.1.]

- (39) Section 1102.1 amend at the end of the paragraph: [-2017].

~~Section 1106.8. Insert: Accessible parking spaces shall have a painted square blue field and either a yellow or white international symbol of access in the field and shall include a sign mounted within the specifications labeled in the ADA Handbook 2010.~~

- (40) Table 2902.1 Insert footnote g to read as follows: [g. Drinking fountains are not required in M Occupancies with an occupant load of 75 or less, B Occupancies with an occupant load of 25 or less, and for dining and/or drinking establishments when water is provided at no charge.]

(b) B. Building foundation regulations. In addition to the rules, regulations, and standards set forth in the International Building Code, as adopted herein, the following additional requirements are adopted and made a part of the building code of the city:

- (1) ~~1.~~ *General.* Stress analysis for any structural element considered by the building official to be unsafe shall be submitted for approval.
- (2) ~~2.~~ *Commercial foundations.* The design of foundations for construction other than residential shall be prepared and certified by a professional engineer registered in the state and approved by the city.

- (3) ~~3.-Concrete slab floors.~~ All concrete slab floors shall meet the following minimum standards:
- ~~a. All concrete slabs on grade shall be nominal four inches thick on a four-inch sand base.~~
 - ~~a. b.~~ All concrete shall be minimum 2,500 psi compressive strength.
 - ~~e. It is recommended that all concrete slabs shall be reinforced with 66/.1010 wire mesh.~~
 - ~~d. All slabs on grade shall be either waterproof concrete or shall have 0.006 inch vapor barrier under slab.~~
 - ~~b. e.~~ All concrete floors shall be a minimum of eight inches above finished grade.

Sec 5-204 Adoption Of The 2015 International Residential Code, As Amended And Modified By The State Uniform Building Code Commission Pursuant To 59 OS Section 1000.23

- (a) ~~A. Adoption.~~ There is hereby adopted that certain code known as the International Residential Code ~~2015~~2018, as amended and modified by the state Oklahoma uniform building code commission pursuant to 59 O.S. § 1000.23, as the one- and two-family dwelling code of the city for the control of buildings and structures as herein provided, referred to herein as the “IRC” or “residential building code.” Each and all of the regulations, provisions, penalties, conditions and terms of the residential building code are hereby referred to, adopted and made a part hereof as if fully set out in this Code, with the additions, insertions, deletions and changes, if any, prescribed herein. Not less than one copy of this code is on file in the office of the clerk.
- (b) ~~B. Amendments.~~ The following sections of the ~~dwelling code~~ International Residential Code are hereby revised as follows:
- (1) Section R101.1. Insert: [The City of Moore, Oklahoma].
 - (2) Section R102.4 Amend to read: [Section R102.4 Referenced codes and standards. The codes, when specifically adopted, and standards referenced in this code shall be considered part of the requirements of this code to the prescribed extent of each such reference and as further regulated in Sections R102.4.1 and R102.4.2. Whenever amendments have been adopted to the referenced codes and standards, each reference to said code and standard shall be considered to reference the amendments as well. The one-to-two family dwellings shall reference and comply with the adopted Electric Code by the City of Moore. Any reference made to NFPA 70 or the Electrical Code shall mean the 2020 National Electrical Code as adopted.]

- (3) Section R102.5 Amend to read: [102.5 Appendices. The provisions in Appendix C and H of the *International Residential Code* and Appendix V (State Statute 748:20-6-51) of the *Oklahoma Adopted International Residential Code* are hereby adopted and considered a part of this Code.]
- (4) Section R103.1 Delete: “Department of Building Safety”; Replace and Insert: [City of Moore’s Community Development Department.]
- (5) Section R104.10.1; Delete this section and refer to Part 12, Chapter 8
- (6) Section R105.2; Building Number 1 Amend to read: [One story detached accessory structures used as playhouses and similar uses, provided that the building has no electric, plumbing, mechanical or fuel/gas connections.]
- (7) Section R105.2; Building Number 3 Amend to read: [Retaining Wall.]
- (8) Section R105.2; Delete: Building, Number 2 and 5
- (9) Section R105.2; Plumbing, Number 3; amend to read: [A repair for stopping a leak in water and/or sanitary sewer service lines where the repair is a minimum of 5 feet away from a tap or meter and the repair is no longer than 5 feet of piping material.]
- (10) Section R105.3.1.1 Delete this section, refer to Part 12, Chapter 8
- (11) Section R106.1.4 Delete this section, refer to Part 12, Chapter 8
- (12) Section R109.1.5.2 amend to read: [R109.1.5.2 Insulation inspection. Insulation inspections shall be made after framing, mechanical, electrical, fuel/gas and plumbing rough-in inspections are approved and before the installation of wallboard materials. Wallboard materials include, but are not limited to lathe, plaster, gypsum wallboard, wood paneling, sheet metal and the like.]
- (13) Section R109.1.6.1 amend to read: [R109.1.6.1 Elevation documentation. If located in a flood hazard area, the documentation of elevations required in Chapter 8 of the Land Development Code shall be submitted to the Floodplain Administrator prior to foundation/footer inspection and final inspection.]
- (14) Section R109.5. Prefabricated Construction. Insert: [Modular construction, manufactured housing and any other prefabricated construction is not permitted in any zoning district within the city limits, unless approved by the board of adjustment as provided in section 12-125 of the City Code].
- (15) Section R112 . delete section and amend to read: [Section R112 Board of Appeals. The appeals procedure shall be specified in Article 5-1D of the Municipal Code.]
- (16) Section R202 Amend “Flex Space” and “Repair Garage”:

- a. [FLEX SPACE. A room or space that can fulfill multiple purposes and does not define the actual use of a room or space. A flexible area that varies in both shape and function. Flex space and also be use in other terms such as bonus room/area, additional space, or any other terminology that does not define the exact use. If a term is used as flex space or a similar description, the room or space shall be identified as a bedroom or otherwise determined by the building official.]
- b. [KITCHEN. Kitchen shall mean an area used, or designated space to be used as a place of preparing of food. The placement or presentence of one or more appliance(s) such as a range, cooktop, garbage disposal, trash compactor, dishwasher or kitchen hood system, shall be considered as a preparation food space.]
- c. [TOWNHOUSE. A single-family dwelling unit constructed in a group of three or more attached units separating each single family dwelling by property lines in which each unit extends from foundation to roof and with a yard or public way on at least two sides.]

(17) Table R301.2(1); Amend table as follows:

GROUND SNOW LOAD^o	WIND DESIGN				SEISMIC DESIGN CATEGORY^f	SUBJECT TO DAMAGE FROM			WINTER DESIGN TEMP^e	ICE BARRIER UNDER-LAYMENT^h	FLOOD HAZARDS^g	AIR FREEZING INDEXⁱ	MEAN ANNUAL TEMP^j
	SPEED^d	Topographic Factor^k	Special Wind Region^l	Windborne Debris Zone^m		Frost		Termite^c					

<u>10 lb/ft</u>	(MPH)				<u>C</u>		<u>Line Depth^b</u>						
	<u>135</u>	<u>No</u>	<u>No</u>	<u>No</u>		<u>Moderate</u>	<u>18"</u>	<u>Moderate to heavy</u>	<u>13⁰ F</u>	<u>Yes</u>	<u>Land Development Code</u>	<u>300</u>	<u>60.9⁰ F</u>

MANUAL J DESIGN CRITERIAⁿ

<u>Elevation</u>	<u>Latitude</u>	<u>Winter Heating</u>	<u>Summer Cooling</u>	<u>Altitude Correction Factor</u>	<u>Indoor Design Temperature</u>	<u>Design Temperature Cooling</u>	<u>Heating Temperature Differenece</u>
<u>451 ft - 3,266 ft</u>	<u>33.909N - 36.605N</u>	<u>11.8° - 25° F</u>	<u>95° - 101.8° F</u>	<u>0.99 - 0.78</u>	<u>68° - 70°F</u>	<u>72° - 75°F</u>	<u>58.2° - 45°F</u>
<u>Cooling Temperture Difference</u>	<u>Wind Velocity Heating</u>	<u>Wind Velocity Cooling</u>	<u>Coincident Wet Bulb</u>	<u>Daily Range</u>	<u>Winter Humidity</u>	<u>Summer Humidity</u>	<u>Left Blank</u>
<u>23° - 26.8°F</u>	<u>15 mph</u>	<u>7.5 mph</u>	<u>67.5° - 77.4°F</u>	<u>M</u>	<u>30%</u>	<u>50% - 65%</u>	<u>Left Blank</u>

- (18) Section R309.4.1 Amend to read: [R309.4.1 Garage door. Must be rated for a 135 mph wind rated door and installed in accordance to manufacturer’s instructions.]
- (19) Section R314.3, add verbiage to existing text in number 3: [flex space, bonus room, any terminology that does not define the exact use” in the first sentence.]
- (20) Section R314.4, remove verbiage in the last sentence from existing text: “not” and “where listed wireless alarms are installed and all alarms sound upon activation of one alarm”.
- (21) Section R322.1, delete section and amend to read: [R322.1 General. Buildings, Structures appliances, equipment, systems and property boundaries where construction occurs in part in flood hazards areas, including substantial improvement and restoration of substantial damage, shall be designed and constructed in accordance with the provisions contained in Chapter 8 of the Land Development Code.]

Section R401.1.2. Addition: Insert after first sentence: Any foundation approved by the Federal Housing Administration (FHA) shall be accepted.

- (22) Section R401.2, amend a paragraph at the end of the section to read: [Every foundation and/or footing, addition or modification to an existing post-tension foundation, regulated by this code shall be designed and sealed by an Oklahoma registered engineer.]
- (23) Section R403.1, amend a sentence and listings at the end of the section to read: [Stress analysis for any structural element considered by the building official to be unsafe shall be submitted for review to determine if acceptable or not. Concrete footings shall meet the following minimum requirements:
- a. Minimum depth of concrete footings on exterior walls shall be 18 inches;
 - b. Minimum width of frame walls shall be 12 inches;
 - c. Minimum width of masonry veneer in place shall be 16 inches;
 - d. All footings shall be 3,000 psi minimum compressive strength concrete or larger;
 - e. Minimum reinforcement of four rows of number 5 rebar top and bottom, two rows on top and two rows on bottom;
 - f. All footing shall be poured in a minimum of twelve inches into undisturbed soil; and
 - g. All cold joints between footings and foundation walls (stem walls) shall be tied together by a number four (4) rebar at every corner not to exceed 6 feet (1,828 mm) on center with embedment of 12 inches (304 mm) into each footing and wall.
- Exception: Temporary structures not exceeding 15 feet in height to the highest ridge of the structure and 600 square feet in area shall be exempt from the requirements of this section. In all cases, structures should be secured to the earth in a minimum of four locations.]
- (24) Section R408.7, delete section and amend to read: [R408.7 Flood resistance. Buildings, Structures and property boundaries where construction occurs in part in flood hazards areas, including substantial improvement and restoration of substantial damage, shall be designed and constructed in accordance with the provisions contained in Chapter 8 of the Land Development Code.]
- (25) Section 602.6.1, delete part of the verbiage: “1 ½ inches (38 mm)”; replace with: [5 inches (127 mm)] and add the sentence: [Fasteners will be offset to prevent splitting of the top plate material.] and add: [See Figure R602.6.1.]

(26) Figure R602.6.1, delete the existing figure and amend the following:

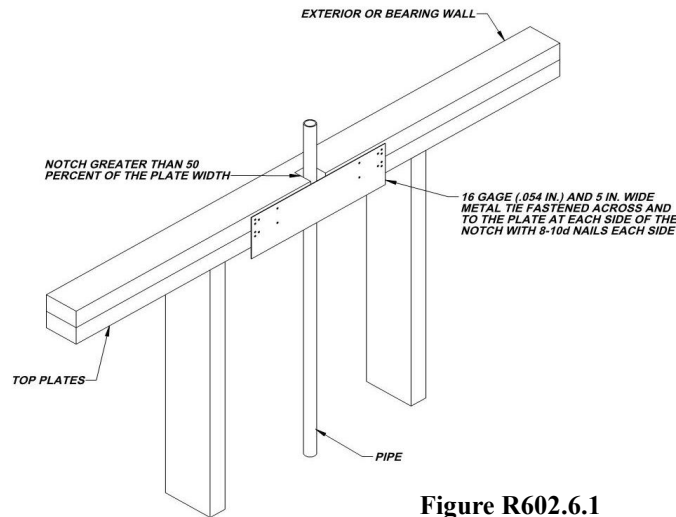

Figure R602.6.1

(27) Section R905.1.2 amend to read: [R905.1.2 Ice barriers. In the roof valleys an ice barrier shall be installed for asphalt shingles, metal roof shingles, mineral surface roll roofing, shale and slate-type shingles, wood shingles and wood shakes. The ice barrier shall consist of not fewer than two layers of underlayment cemented together, or a self-adhering polymer modified bitumen sheet shall be used in place of normal underlayment and extend from the lowest edge of the roof surface.]

Exception: Detached accessory structures not containing conditioned floor area.]

(28) Section M2005.2, add verbiage to existing text: Add the word, [Existing] at the beginning of the second sentence and add the words: [sleeping rooms, toilet rooms, surgical rooms] in the middle of the second sentence; add a sentence after the second sentence to read: [Access to such enclosure may be from the bedroom or bathroom when through a solid door, weather-stripped in accordance with the exterior door air leakage requirements and equipped with an approved self-closing device and a carbon monoxide alarm is in place.]

(29) Section G2412.7 (401.7), add verbiage to existing text to read: [Piping from multiple meter installations shall be marked with approved permanent identification that has a contrasting background, durable material, minimum of 1/2 inch lettering that is engraved or pressed lettering by the installer so that the piping system supplied by the meter is readily identifiable.]

(30) Section G2415.1 (404.1) add a second paragraph to read: [Both ends of each section of medium pressure gas piping shall identify its operating gas pressure with an approved tag. The tags are to be composed of aluminum or stainless steel and the following wording shall be stamped into the tag:

"WARNING: [number] to [number] psi gas pressure - Do Not Remove]

- (31) Section G2415.12 (404.12), delete the verbiage, “12 inches (305 mm)” and replace and amend with [18 inches (457 mm)] and delete the end of the sentence that reads: “except as provided for in Section G2415.12.1”.
- (32) Section G2415.12.1 (404.12.1), delete this section.
- (33) Section G2415.13 (404.13), add a sentence at the end to read: [Where over-excavated, the trench shall be backfilled to the proper grade compacted with manufacturer’s instructions. Piping shall not be supported on rocks or blocks at any point. Rocky or unstable soil shall be over-excavated by two or more pipe diameters and brought to the proper grade with suitable compacted material.]
- (34) Section G2415.13.1 (404.13.1), amend to read: [G2415.13.1 (404.13.1) Fuel/Gas shared trench. Where a fuel/gas piping is installed in a trench, sharing of the trench with electrical service, electrical feeders, electrical conduit, electrical branch circuits water piping and building sewers is prohibited. The fuel/gas piping must have an 18 inch separation.]
- (35) Section G2415.13.2 (404.13.2), amend to read: [G2415.13.2 (404.13.2) Warning ribbon. Underground piping shall have their location identified by a warning ribbon that is a minimum of two-inch-wide yellow background color and black wording that reads, “Caution”, “Gas Line Below”, “Buried Gas Line” or other type of wording accepted by the building official. The warning ribbon shall be placed in the trench not less than 12 inches above the underground piping installation.]
- (36) Section G2415.13.3 (404.13.3), amend to read: [G2415.13.3 (404.13.3) Protection of footing. Trenching installed parallel to footings and wall shall comply with Section P2604.4.]
- (37) Section G2417.1 (406.1), add a sentence at the end to read: [The permit holder shall make the applicable tests prescribed in Sections 2417.1.1 through 2417.1.6 to determine compliance with the provisions of this code. The permit holder shall give reasonable advance notice to the building official when the piping system is ready for testing. The equipment, material, power and labor necessary for the inspections and test shall be furnished by the permit holder and the permit holder shall be responsible for determining that the work will withstand the test pressure prescribed in the following tests.]
- (38) Section G2417.4.2 (406.4.2), replace and amend to read: [G2417.4.2 (406.4.2) Test duration. The test duration shall be held for a length of time satisfactory to the Building Official, but in no case for less than fifteen (15) minutes. For welded piping, and for piping carrying gas pressures in excess of fourteen (14) inch water column pressure (3.48 kPa), the test duration shall be held for a length of time satisfactory to the Building Official, but in no case for less than thirty (30) minutes.]
- (39) Section G2422.1.2.3 (411.1.3.3), delete exception number 1 and number 4.

- (40) Section G2424.1 (415.1), add at the end of the sentence to read: [and in a neat and orderly workman fashion.]
- (41) Section P2601.4, amend section to read: [P2601.4 Availability. A public water main or public sewer system shall be considered available for a private service line to a building when the building is located within ~~300~~ 500 feet of the public water or sewer system.]
- (42) Section P2603.5, delete and amend to read: [P2603.5 Freezing. Water pipes shall not be installed outside of a building, in attics or crawl spaces, concealed in outside walls, or in any other place subjected to freezing temperatures unless adequate provisions is made to protect such pipes from freezing in insulation or heat or both. Exterior water supply system piping shall be installed not less than 24 inches (610 mm) below grade.]
- (43) Section P2603.5.1, insert the number [12] to designate the depth and add a sentence at the end of the paragraph to read: [If proper fall cannot be achieved, an alternative depth must be approved by the building official.]
- (44) Section P2604.4, add at the end of the sentence to read: [Installation must meet this code section and Figure 2604.4.]
- (45) Figure 2604.4, amend the figure:

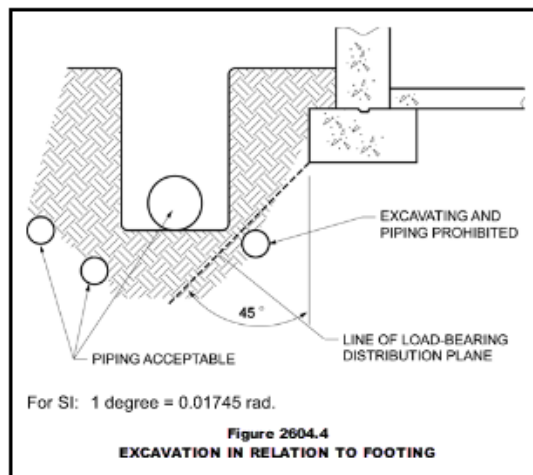

- (46) Section P2804.6.1, add an exception to number 4 to read: [Exception: Multiple relief devices may be installed to a single T & P discharge piping system when approved by the administrative authority and permitted by the manufacturers installation instructions and installed with those instructions.] and in number 5 delete: “the floor, to the pan serving the water heater or storage tank, to a waste receptor” and replace within the sentence: [an approved location].
- (47) Section P3002.2, delete and amend to read: [P3002.2 Building sewer. Building

sewer shall not be smaller than three inches internal diameter. All tapping saddles shall be plastic saddle tees with one strap on each side of tee, completely secured around main line. Building sewer pipe shall be for six-inch or smaller PVC SCH-40 and for six-inch and larger either PVC SCH-40 or Heavy Duty SDR-35. Forced main sewer piping shall conform to one of the standards for ABS plastic pipe, copper or copper-alloy tubing, PVC plastic pipe or pressure-rated pipe indicated in Table P3002.2]

- (48) Section P3003.9.1, add the verbiage within the text to read: [that is fully banded].
- (49) Section P3003.9.2, delete the verbiage that reads: “or other approved primer” and delete all of the exceptions.
- (50) Section P3005.2.3. Delete and replace with: [There shall be two directional cleanouts with a backwater valve in between the two directional cleanouts near the junction of the building drain and building sewer. The two directional cleanouts and backwater valve shall be outside the building wall located within 10 feet developed length of piping upstream of the junction, provided that it is brought up to finish grade.]
- (51) Section P3008.1, delete and amend to read: [P3008.1 Where required. There shall be two directional cleanouts with a backwater valve in between the two directional cleanouts near the junction of the building drainage and building sewer. The two directional cleanouts and backwater valve shall be outside the building wall, provided that it is brought up to finish grade. Backwater valves shall be subject to the following specifications:
- a. The installation of backwater devices shall be in accordance with lawful requirements of the administrative authority.
 - b. Shall be installed in the building drain branch which receives only the discharge from fixtures connected to branches which are located below ground level.
 - c. All bearing parts of corrosion-resistant materials.
 - d. Working parts shall be readily accessible for service and repairs; and
 - e. Constructed so a mechanical seal against backflow will be provided.]

~~Sections E3401 to E4304. Delete Sections E3401 to E4304 and replace with the 2014 NEC as adopted by the state uniform building code commission pursuant to 59 O.S. § 1000.23 and the city.~~

- (52) Section E3401.5, amend section to read: [E3401.5 Prohibiting uses of aluminum. Aluminum wire and conductors are prohibited.]

- (53) Section E3406.2, delete section and amend to read: [E3406.2 Conductor material. Conductors used to conduct current shall be of copper.]
- (54) Section E3601.6.1, add a sentence at the end of the section to read: [Where a building or structure is supplied by more than one service, or any combination of branch circuits, feeders, and services, a permanent plaque or directory shall be installed with a contrasting background, durable material, engraved or pressed lettering with a minimum of 1/2 inch lettering height at each service disconnect location denoting all other services, feeders and branch circuits supplying that building or structure and the areas served by each.]
- (55) Section E3601.6.2, add a sentence at the end of the section to read: [Emergency Service Disconnect means for a one- and two- family dwelling is to reference 230.85 of the 2020 National Electrical Code.]
- (56) Section E3803.1.1, amend to read: [E3803.1.1 Shared trench. Where a buried cable, raceway or conduit is installed in a trench, sharing of the trench with fuel/gas piping, water piping and building sewers is prohibited. Buried electrical must have a minimum of 18 inches separation.]
- (57) Section E3803.1.2, amend to read: [E3803.1.2 Protection of footing. Trenching installed parallel to footings and wall shall comply with Section P2604.4.]
- (58) Section E3907.10, amend to read: [E3907.10 Mounting height. Enclosures for switches or overcurrent devices shall be installed so the bottom of the enclosure is not less than 2 feet (600 mm) above the finish grade or working platform unless specifically listed or approved for an alternative mounting height.]

~~Section Addition:~~

~~Part IV Energy Construction.~~

~~Part V Mechanical.~~

~~Part VI Fuel Gas.~~

~~Part VII Plumbing.~~

~~Part VIII Electrical.~~

- (c) ~~C.~~ Adoption of residential wind code for one-to-two family dwelling. The following additions are hereby included in the residential building code for the purposes of establishing minimum regulations governing residential construction for high wind resistance:

- (1) ~~1~~ Roof sheathing (OSB or plywood) shall be nailed with 8d ring shank (0.131" by 2.5") or 10d (0.148" by 3") nails on four-inch on center along the edges and six-inch on center in the field. Dimensional lumber decking is not allowed.
- (2) ~~2~~ Maximum spacing for roof framing shall be 16 inches on center. Minimum nominal sheathing panel size shall be 7/16. Minimum wood structural panel span rating shall be 24/16.
- (3) ~~3~~ Connections for roof framing shall be designed for both compression and tension, and may include nail plates or steel connection plates. Connections for roof framing shall include connections on rafters, web members, purlins, kickers, bracing connections, and the connections to interior brace wall top plates or ceiling joists.
- (4) ~~4~~ Gable end walls shall be tied to the structure, and may include steel connection plates or straps. The connections shall be made at the top and bottom of the gable end wall.
- (5) ~~5~~ Structural sheathing panel (OSB or plywood) shall be required for gable end walls.
- (6) ~~6~~ Hurricane clip or framing anchor shall be required on all rafter to wall connections.
- (7) ~~7~~ The upper and lower story wall sheathing shall be nailed to the common rim board.
- (8) ~~8~~ All walls shall be continuously sheathed with structural sheathing (OSB or plywood) using the CS-WSP method. Garage doors shall be framed using the sheathed portal frame method CS-PF. No form of intermittent bracing shall be allowed on an outer wall. Intermittent bracing may only be used for interior braced wall lines.
- (9) ~~9~~ Nailing of wall sheathing (OSB or plywood) shall be increased to 8d ring shank (0.131" by 2.5") or 10d (0.148" by 3") nails on four-inch on center along the edges and six-inch on center in the field.
- (10) ~~10~~ Structural wood sheathing shall be extended to lap the sill plate and nailed to the sill plate using a four-inch on center along the edges. Structural wood sheathing shall be nailed to rim board if present with 8d ring shank (0.131" by 2.5") or 10d (0.148" by 3") nails on four-inch on center along both the top and bottom edges of the rim board.
- (11) ~~11~~ Garage doors shall be rated to 135 mph wind or above.
- (12) ~~12~~ Exterior wall studs shall be 16-inch on center.

(d) ~~D.~~ *Building foundation regulations.* In addition to the rules, regulations, and standards set forth in the International Residential Code, as adopted herein, the following additional requirements are adopted and made a part of the building code of the city:

(1) ~~1.~~ *General.* Stress analysis for any structural element considered by the building official to be unsafe shall be submitted for approval.

~~2.~~ *Foundations and footings.* All exterior walls shall have footings of the following minimum standards:

~~a.~~ Minimum depths of concrete footings on exterior walls: 18 inches.

~~b.~~ Minimum width for frame walls: ten inches.

~~c.~~ Minimum width for veneer walls: 12 inches.

~~d.~~ All footings shall be 3,000 psi, minimum compressive strength concrete and reinforced with four rows, two up and two down, with No. 5 bar top and bottom.

~~e.~~ All footings shall be poured in a minimum of six inches into undisturbed soil.

~~f.~~ Where pier and grade beam type of foundation is proposed for residential construction, design of grade beam and piers shall be:

~~(1)~~ *Piers.*

~~(A)~~ Diameter: ten inches minimum.

~~(B)~~ Depth: 24 inches minimum.

~~(C)~~ Spacing: eight feet on center with one No. 5 bar for full length of pier and extending into beam.

~~(2)~~ *Grade beam, minimum width.*

~~(A)~~ Frame: six inches, except that an eight inch beam may be flared to be covered by base trim.

~~(B)~~ Masonry or masonry veneer: eight inches.

~~(C)~~ Minimum effective depth: 14 inches; however, where grade beam supports wood floor framing the minimum effective

depth shall be 18 inches in order to provide required clearance under joints.

~~(D) Reinforce with two bars at the top and bottom of the beam as follows: frame, four No. 4 bars; and masonry or masonry veneer, four No. 5 bars. Where grade beam is flared at the top, reinforce with one No. 6 bar instead of two No. 4 bars~~

~~(3) Concrete slab floors. All concrete slab floors shall meet the following minimum standards:~~

~~(A) All concrete slabs on grade shall be nominal four inches thick on a four inch sand base.~~

~~(B) All concrete shall be minimum 2,500 psi compressive strength.~~

~~(C) It is recommended that all concrete slabs shall be reinforced with 66/1010 wire mesh.~~

~~(D) All slabs on grade shall be either waterproof concrete or shall have 0.006 inch vapor barrier under slab.~~

~~(E) All concrete floors shall be a minimum of eight inches above finished grade.~~

State Law reference— Adoption by reference, 11 O.S. § 14-107.

Sec 5-206 Adoption Of Standard Specifications For The Construction Of Water And Sewer

A certain document, one copy of which is on file in the office of the city clerk, being designated as the "City of Moore Standard Specifications for ~~the Construction of Water and Sewer~~ Public Works Construction," and "Construction Standards and Details for Public Works Construction" dated ~~February 1990~~ September 18, 2023, as developed and prepared by Wyatt, Doyle and Butler Engineers, Inc., is hereby adopted as the construction code of water and sewer for the city. The specifications set forth the standards and specifications for the construction of water and sewer establish minimum regulations governing the installation of water mains, installation of sewer mains, incidental construction, attendant installation and maintenance of water and sewer mains, and standards for earth work, excavation, disposal of materials, adjustment of existing structures, foundations and bedding, and backfill, all relative to the construction of water and sewer. Each and all of the regulations, provisions, penalties, conditions and terms of the standard specifications are hereby referred to, adopted and made a part hereof as if fully set out in this section.

State Law reference— Adoption by reference, 11 O.S. § 14-107.

Sec 5-207 Adoption Of Paving, Sidewalk, And Driveway Specifications

A certain document commonly known as "~~Standard P.C.C. Paving Details, Standard Driveway and Sidewalk Details and Standard A.C. Paving Details~~, City of Moore Standard Specifications for Public Works Construction," and "Construction Standards and Details for Public Works Construction" one copy of which is on file in the office of community development director, is hereby adopted as the specifications for same and shall be known as the paving code of the city. Subsequent revisions, modifications, codifications or additions of the paving code shall become effective as available, for the control of paving as herein provided. Each and all of the regulations, provisions, conditions, and terms of the paving code are hereby referred to, adopted and made a part hereof as if fully set out in this section.

The maximum width of a driveway shall be calculated as a grand total of the property boundary. The existing and proposed widths of all driveways within a one-to-two family lot shall be calculated as a whole. The maximum combination width of residential driveways shall not exceed 30 feet in width. Turning radii are not placed in the total width calculation. The minimum/maximum radii for a one-to-two family dwelling is five feet. The proposal of a larger radii must get approval from the Community Development Director.

Sec 5-210 ~~Private Water Wells Prohibited~~ Reserved

~~It is unlawful and an offense for any person to drill a well for the production of water upon property not owned and controlled by the city. It is unlawful and an offense for any person to produce water from any well hereafter drilled in violation of this section. This section shall not apply to any property placed in an agricultural zoning classification under the zoning ordinances of the city.~~

ARTICLE 5-2D ONE-TO-TWO FAMILY AWNINGS, CARPORTS AND PATIO COVERS

Sec 5-251 Definition

Sec 5-252 Construction Restrictions

Sec 5-253 Permits And Fees

Sec 5-251 Definition

Awnings, carports, and patio covers, individually or in combinations, as used herein, are defined as any structure, whether attached to an existing structure or freestanding, which is constructed for the purpose of providing a roof type cover only, for shelter from the sun, rain, snow, sleet or hail.

Sec 5-252 Construction Restrictions

Awnings, carports and patio covers which extend beyond the front building line, toward the street, or beyond the side building line on side streets, may be constructed if they meet the following requirements:

- (a) ~~A~~. They are not to exceed more than 20 feet beyond the front building line, but in no instance beyond the front property line of interior lots;
- (b) ~~B~~. They are not to extend more than 20 feet beyond the side building line, but in no case beyond the side property line of corner lots;
- (c) ~~C~~. They must not be, at any point on the structure, closer than five feet to an adjacent property line; except, those houses that have an existing one car garage as of November 2, 1995, may erect a carport within one foot of the side property line, provided the structure may not divert any stormwater to the adjacent property;
- (d) ~~D~~. Construction details must conform to the following:
 - (1) ~~1~~. The structure must be designed to support a load of 20 pounds per square foot in addition to the weight of the structure;
 - (2) ~~2~~. Awnings, carports and patio covers which are attached to an existing structure shall be attached with one-quarter inch or larger lag screws in a substantial manner and shall be anchored to each wall stud or to a masonry wall. One side of attached awnings, carports or patio cover structures shall be supported by 1½-inch diameter by 14 gauge steel columns, or columns of equivalent strength, set in concrete footings not less than 12 inches deep nor less than 12 inches in diameter;
 - (3) ~~3~~. Freestanding carports or patio covers shall be supported by 2½-inch diameter by 14 gauge steel columns or columns of equivalent strength, set in concrete footings not less than 24 inches deep nor less than 12 inches in diameter;
 - (4) ~~4~~. All concrete in footings shall be 2,000 pounds per square inch quality;
 - (5) ~~5~~. Roof slope shall be at least 3/16 -inch per foot; and
 - (6) ~~6~~. All bolts and screws used in the structure shall be cadmium plated or equal.

Sec 5-253 Permits And Fees

- (a) ~~A~~. A permit must be obtained from the city clerk upon written application showing compliance with this article and other applicable ordinances of the city.
- (b) ~~B~~. Such application shall contain the address of the applicant along with a detailed drawing showing the desired specification of the proposed awning, carport or patio cover and showing on such drawing compliance with this article in all particulars. The

application will be on forms prepared by the city clerk and shall contain such other information as is deemed necessary by him.

- (c) ~~€~~: No permit will be issued until the permit fee is paid to the city clerk. It shall be an offense to construct an awning, carport or patio cover without having first secured a permit as provided in this article.

Severability. If any of the provisions of this ordinance are determined to be unconstitutional or unlawful by any court of competent jurisdiction, the remainder shall be severable and unaffected.

Repealer. Any ordinance or parts thereof in conflict with this section are hereby repealed.

PASSED AND APPROVED THIS 18TH DAY OF DECEMBER, 2023.

MELISSA HUNT, Vice-Mayor

ATTEST: *(Seal)*

VANESSA KEMP, City Clerk

APPROVED AS TO FORM AND LEGALITY:

Brian K. Miller, City Attorney

**CITY OF MOORE
ORDINANCE NO. 1040.23**

AN ORDINANCE AMENDING PART 5, CHAPTER 3, ARTICLE A, SECTIONS 5-301, 5-302 AND 5-307; ADOPTING THE 2018 INTERNATIONAL PLUMBING CODE AS AMENED AND MODIFIED BY THE OKLAHOMA UNIFORM BUILDING CODE COMMISSION AND ADOPTING LOCAL AMENDMENTS TO SAID CODE; ESTABLISHING MINIMUM REGULATIONS GOVERNING THE DESIGN, INSTALLATION AND CONSTRUCTION OF PLUMBING SYSTEMS WITHIN MOORE, OKLAHOMA; PROVIDING FOR SEVERABILITY; PROVIDING FOR REPEALER.

BE IT ORDAINED BY THE CITY COUNCIL OF THE CITY OF MOORE, OKLAHOMA THAT PART 5, CHAPTER 3, ARTICLE A, SECTIONS 5-301, 5-302 AND 5-307 ARE HEREBY AMENDED TO READ AS FOLLOWS:

ARTICLE 5-3A GENERAL PROVISIONS

Sec 5-301 Adoption Of The ~~2015~~ International Plumbing Code, ~~As Amended And Modified By The State Uniform Building Code Commission Pursuant To 59 OS Section 1000.23~~

Sec 5-302 Additions, Insertions And Changes

Sec 5-303 Administration

Sec 5-304 Dangerous And Insanitary Construction

Sec 5-305 Backwater Valves; When Required; Specifications

Sec 5-306 Violations And Penalties

Sec 5-307 Plumbing Committee

Sec 5-301 Adoption Of The ~~2015~~ International Plumbing Code, ~~As Amended And Modified By The State Uniform Building Code Commission Pursuant To 59 OS Section 1000.23~~

Pursuant to section 2-15 of the Charter, the council may by ordinance adopt, by reference, codes which shall be considered to have the same effect as if set out in full in this Code. Pursuant to this authority, the city council hereby ordains that a certain document, at least one copy of which is on file in the office of the city clerk, being marked and designated as "The International Plumbing Code ~~2015~~, 2018 edition" as amended and modified by the ~~state~~ Oklahoma uniform building code commission pursuant to 59 O.S. § 1000.23, is hereby adopted as the plumbing code of the city; for the control of buildings and structures as herein provided, referred to herein as the "plumbing code" or "IPC". Each and all of the regulations, provisions, penalties, conditions and terms of the International Plumbing Code are hereby referred to, adopted and made a part hereof, as if fully set out in this Code, with the additions, insertions, and changes, if any, as prescribed and set out herein.

State Law reference— Adoption by reference, 11 O.S. § 14-107.

Sec 5-302 Additions, Insertions And Changes

- (a) The following sections of the plumbing code are hereby revised, deleted, or amended as set out below. Items in brackets [] are phrases that shall be deemed inserted into the appropriation section of the plumbing code:

- (1) ~~A.~~ Section 101.1, insert: [City of Moore].
 - (2) Section 106.2, insert: [3. A repair for stopping a leak in water and/or sanitary sewer service lines where the repair is a minimum of 5 feet away from a tap or meter and the repair is no longer than 5 feet of piping material.]
 - (3) ~~B.~~ Section 106.6.2, Insert: [As provided in the city's adopted fee schedule].
 - (4) ~~B.~~ Section 106.6.3, delete and amend to read: [106.6.3 Fee Refunds. The code official shall establish a policy for authorizing the refunding of fees.].
 - (5) ~~C.~~ Section 108.4 Violation Penalties, delete existing language in this section and replace with the following: [Penalties: Any person who shall violate a provision of this code, or shall fail to comply with any of the requirements thereof, or who shall install plumbing work in violation of an approved plan of lawful directive of this code, shall be guilty of a municipal offense, punishable by a fine of not more than \$200.00 or by imprisonment not to exceed ten days, or both such fine and imprisonment of an offense, and, upon conviction thereof, shall be subject to punishment as provided in section 1-108].
 - (6) Section 108.5, amend to read: [108.5 Stop work orders. Upon notice from the Code Official, work on any plumbing system regulated by this code is being performed in a manner either contrary to the provisions of this code or dangerous or unsafe, the Code Official is authorized to issue a stop work order. The stop work order shall be in writing and shall be given to the owner of the property involved, to the owner's authorized agent or to the person performing the work. The stop work order shall state the reason for the order and the conditions under which the cited work will be permitted to resume. Any person who shall continue any work on the plumbing system after having been served with a stop work order, except such work as the person is directed to perform to remove the violation or unsafe condition, shall be subject to penalties as prescribed law.]
- ~~D. Section 109.2.1 Qualifications, delete existing language in this section and replace with the following: [This board shall be composed of two members who shall be plumbing contractors licensed with the city and two members who shall be journeyman plumbers licensed with the city; the building official shall serve as ex officio member].~~
- (7) Section 109, Board of Appeals, delete existing language and replace with the following: [Section 109 Board of Appeals. Please reference Article 5-1D of the City of Moore's Municipal Code.]
 - (8) ~~E.~~ Section 301.8 is hereby added and shall read as follows: [A public water main or public sewer system shall be considered available for a private service line to a building when the building is located within ~~200~~ 500 feet of the public water or sewer].

- (9) ~~F~~. Section 305.4, delete last sentence and insert: [Water service piping shall be installed below record frost penetration but not less than two feet below grade].
- (9) Section 305.4.1, add depth in inches to read: [12] and add a sentence at the end of the section to read: [If proper fall cannot be achieved, an alternative depth must be approved by the building official.]
- (10) Section 307.5, add a sentence at the end of the section to read: [Installation must meet this code section and Figure 307.5]
- (11) Figure 307.5, amend figure as shown:

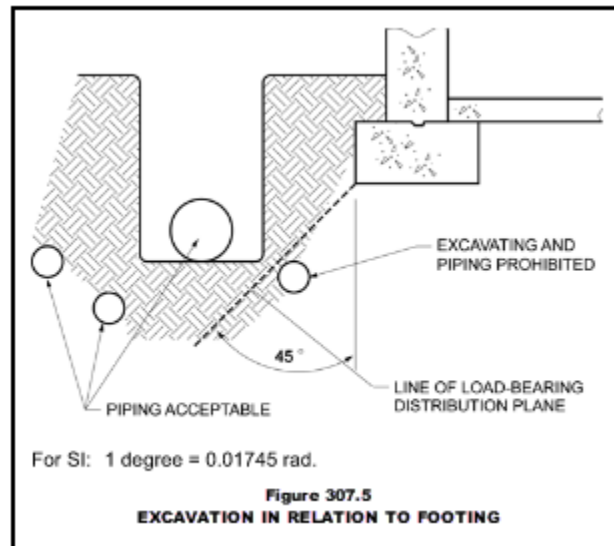

- (12) Section 413.4, delete from the sentence: “public laundries and central washing facilities” and replace and amend to read: [Required location for floor drains. Floor drains shall be installed in the following areas:]. Amend additional required locations for floor drains to read: [2. Commercial kitchens, in lieu of floor drains in commercial kitchens, the Code Official may accept floor sinks.] and [3. Public restrooms.].
- (13) ~~G~~. Insert section 703.7 to read as follows: [Building Sewer Sizing: Building sewer shall not be smaller than three-inch internal diameter. All tapping saddles shall be plastic saddle tees with one strap on each side of tee, completely secured around main line. Building sewer pipe shall be for six-inch or smaller PVC SCH-40 and for six-inch and larger either PVC SCH-40 or Heavy Duty SDR-35.]
- ~~H. Section 705.2.1, insert last sentence to read as follows: [Any elastomeric joint on an underground sewer shall be fully banded].~~
- (14) Section 705.10.1 Mechanical Joint, add verbiage in the first sentence to read: [that is fully banded].
- (15) Section 705.10.2 Solvent cementing., delete all of the exceptions.

- (16) Section 714.1, amend to read: [714.1 Sewage backflow. There shall be two directional cleanouts with a backwater valve in between the two directional cleanouts near the junction of the building drainage and building sewer. The two directional cleanouts and backwater valve shall be outside the building wall, provided that it is brought up to finish grade. Backwater valves shall be subject to the following specifications:
- a. 1. The installation of backwater devices shall be in accordance with lawful requirements of the administrative authority.
 - b. 2. Shall be installed in the building drain branch which receives only the discharge from fixtures connected to branches which are located below ground level.
 - c. 3. All bearing parts of corrosion-resistant materials.
 - d. 4. Working parts shall be readily accessible for service and repairs; and
 - e. 5. Constructed so a mechanical seal against backflow will be provided.]
- (17) Section 803.3, amend to read: [803.3 Special waste pipe, fittings, and components. Pipes, fittings, and components receiving or intended to receive the discharge of any fixture into which acid or corrosive chemicals are placed shall be constructed of CPVC, high silicone iron, PP, PVDF, chemical resistant glass, or glazed ceramic materials.]
- (18) Appendix B, Rates of Rainfall for Various Cities., Amend Appendix B of the 2018 International Plumbing Code.
- (19) Appendix C, Structural Safety., Amend Appendix C of the 2018 International Plumbing Code.
- (20) Appendix D, Degree Day and Design Temperatures., Amend Appendix D of the 2018 International Plumbing Code.
- (21) Appendix E, Sizing of Water Piping System., Amend Appendix E of the 2018 International Plumbing Code.

Sec 5-307 Plumbing Committee

This committee shall be formed to review proposed adoptions that pertain to the plumbing and fuel gas codes. The Committee shall be composed of five members. Four of the members shall carry either a valid plumbing contractor or journeyman license with the city and state or a plumbing engineer licensed with the state. The fifth member shall be a plumbing inspector with the City of Moore.

Severability. If any of the provisions of this ordinance are determined to be unconstitutional or unlawful by any court of competent jurisdiction, the remainder shall be severable and unaffected.

Repealer. Any ordinance or parts thereof in conflict with this section are hereby repealed.

PASSED AND APPROVED THIS 18TH DAY OF DECEMBER, 2023.

MELISSA HUNT, Vice-Mayor

ATTEST: *(Seal)*

VANESSA KEMP, City Clerk

APPROVED AS TO FORM AND LEGALITY:

Brian K. Miller, City Attorney

**CITY OF MOORE
ORDINANCE NO. 1041.23**

AN ORDINANCE AMENDING PART 5, CHAPTER 4, ARTICLE A, SECTIONS 5-401 AND 5-411; ADOPTING THE 2020 NATIONAL ELECTRICAL CODE AS AMENDED AND MODIFIED BY THE OKLAHOMA UNIFORM BUILDING CODE COMMISSION AND ADOPTING LOCAL AMENDMENTS TO SAID CODE; ESTABLISHING MINIMUM REGULATIONS GOVERNING THE DESIGN, INSTALLATION AND CONSTRUCTION OF ELECTRICAL SYSTEMS WITHIN MOORE, OKLAHOMA; PROVIDING FOR SEVERABILITY; PROVIDING FOR REPEALER.

BE IT ORDAINED BY THE CITY COUNCIL OF THE CITY OF MOORE, OKLAHOMA THAT PART 5, CHAPTER 4, ARTICLE A, SECTION 5-401 AND 5-411 ARE HEREBY AMENDED TO READ AS FOLLOWS:

ARTICLE 5-4A GENERAL PROVISIONS

Sec 5-401 Adoption Of The ~~2014~~ National Electrical Code; NFPA 70, ~~As Adopted By The State Uniform Building Code Commission Pursuant To 59 OS Section 1000.23~~

Sec 5-402 Provisions Declared To Be Minimum Requirements

Sec 5-403 Electrical Installation Permit Required

Sec 5-404 Temporary Permit; Fees

Sec 5-405 Inspection, Not To Conceal

Sec 5-406 Denial Of Permit; Certificate Of Inspection, Utility Companies

Sec 5-407 Wiring Protection, When Inspected

Sec 5-408 Defective Workmanship And Materials

Sec 5-409 Relocated Buildings

Sec 5-410 Inspection No Relief From Responsibility

Sec 5-411 Electrical ~~Board~~ Committee

Sec 5-401 Adoption Of The ~~2014~~ National Electrical Code; NFPA 70, ~~As Adopted By The State Uniform Building Code Commission Pursuant To 59 OS Section 1000.23~~

- (a) ~~A.~~ For the purposes of establishing basic minimum requirements necessary for safety in the use of electricity, and of prescribing rules and regulations governing the installation of electrical wiring and appliances within the city, there is hereby adopted that certain code known as the ~~2014~~ **2020** National Electrical Code—NFPA 70 with Appendix H, as adopted by the ~~state~~ Oklahoma uniform building code commission pursuant to 59 O.S. § 1000.23, thereof and the whole thereof, save and except such provisions as are hereinafter deleted, modified or amended, referred to herein as the "electrical code" or "NEC"; of which code not less than one copy has been and now is filed in the office of the clerk. The electrical code is hereby incorporated as fully as if set out at length herein.
- (b) ~~B.~~ The ~~2014~~ 2020 National Electric Code is hereby amended as follows:

~~1. Insert new section 305 to read as follows: Aluminum wire may only be used if it is sized at 4/0 or larger, used for service and feeders only and installed as per~~

~~manufacturer's installation instructions.~~

2. ~~Insert new section 300.1(D) to read as follows: All commercial structures shall be wired in conduit. NM cable shall not be used.~~
- (1) Section 80.5.1, [The City of Moore hereby adopts Appendix H, "Administration and Enforcement" of the 2020 National Electrical Code.]
- (2) Section 80.7, insert the name: [City of Moore]
- (3) Section 80.15, delete existing language and replace with the following: [Section 80.15 Board of Appeals. Please reference Article 5-1D of the City of Moore's Municipal Code.]
- (4) Section 80.19 (E), add language at the end of the sentence to read: [As provided in the City's adopted fee schedule and The code official shall establish a policy for authorizing the refunding of fees.]
- (5) Section 80.19 (F)(3), delete part of the last sentence that reads: "or until ___ days have elapsed form the time of such notification, provided that a large installation, where the concealment of equipment proceeds continuously, the person, firm or corporation installing the equipment shall vie the Electrical Inspector due notice in advance and inspections shall be made periodically during the progress of the work." and replace text at the end to read: [or Building Official.]
- (6) Section 80.23 (A)(3), add a section at the end to read: [Stop work orders. Upon notice from the Code Official, work on any electrical system regulated by this code is being performed in a manner either contrary to the provisions of this code or dangerous or unsafe, the Code Official is authorized to issue a stop work order. The stop work order shall be in writing and shall be given to the owner of the property involved, to the owner's authorized agent or to the person performing the work. The stop work order shall state the reason for the order and the conditions under which the cited work will be permitted to resume. Any person who shall continue any work on the electrical system after having been served with a stop work order, except such work as the person is directed to perform to remove the violation or unsafe condition, shall be subject to penalties as prescribed law.]
- (7) Section 80.23 (B)(3) Penalties, delete section and insert the following to read: [Section 80.23 (B)(3) Penalties. Persons who shall violate a provision of this code or shall fail to comply with any of the requirements thereof or who shall erect, install, alter or repair mechanical work in violation of the approved construction documents or directive of the code official, or of a permit or certificate issued under the provisions of this code shall be guilty of a listed in the city municipal code section 1-108. Each day that a violation continues after due notice has been served shall be deemed a separate offense.]

- (8) Section 80.25 (C), delete section.
- (9) Section 80.27, delete section and insert the following to read: [80.27 Inspector's Qualifications. To be an electrical inspector, the said individual, company or firm must comply with the Oklahoma State adoptions and conform to their standards and registration.]
- (10) Section 80.35, delete section and insert the following to read: [80.35 Effective Date. Article 8 shall take effect as listed in Ordinance 1041.23.]
- (11) Section 110.5 Conductors, add a sentence to the end of the section to read: [The use of aluminum conductors shall be a minimum 4/0 or larger for non-residential uses for service and feeders only. Aluminum is not allowed in one-to-two family dwelling, R1, R-2, R-3, R-4 occupancy uses and any sleeping quarters.]
- (12) 3.—Section 210.19(A)(4) is hereby amended by: Deleting the number "14" and inserting the number [12.]
- (13) Section 230.2(E), amend to read: [230.2 (E) identification. Where a building or structure is supplied by more than one service, or any combination of branch circuits, feeders, and services, a permanent plaque or directory shall be installed with a contrasting background, durable material, engraved or pressed lettering with a minimum of 1/2 inch lettering height at each service disconnect location denoting all other services, feeders and branch circuits supplying that building or structure and the areas served by each.]
- (14) Section 230.70(A)(4), add a sentence at the end of the section to read: [(4) Emergency Service Disconnect means for a one- and two- family dwelling is to reference 230.85.]
- (15) 4- Section 250.118 is hereby deleted, and the following language is hereby substituted: [250.118 Types of Equipment Grounding Conductors. The equipment grounding conductor run with the circuit conductors shall be copper only. This conductor shall be solid or stranded; insulated, covered, or bare; and in the form of a wire of any shape.
- All raceways or cable assemblies shall include a green or bare equipment grounding conductor, said conductor shall be bonded to all non-current carrying metal parts of the electrical system.]
- (16) Section 300.1 (D), amend to read: “[300.1 (D) Prohibiting the use of aluminum wire. The use of aluminum conductors shall be a minimum 4/0 or larger for non-residential uses for service and feeders only. Aluminum is not allowed in one-to-two family dwelling, R1, R-2, R-3, R-4 occupancy uses and any sleeping quarters.]

- (17) Section 300.1 (E), amend to read: [300.1 (E) Commercial Structures. All commercial structures shall be wired accepted by the NEC. NM cable shall not be used.]
- (18) Section 300.5(F)(1), add and amend to read: [300.5(F)(1) Shared trench. Where a buried cable, raceway or conduit is installed in a trench, sharing of the trench with fuel/gas piping, water piping and building sewers is prohibited. Buried electrical must have a minimum of 18 inches separation.]
- (19) Section 300.5(F)(2), amend to read: [300.5(F)(2) Protection of footing. Trenching installed parallel to footings and wall shall comply with Section 307.5 of the International Plumbing Code.]
- (20) Section 310.3(B) delete the end of the sentence of the first paragraph that reads: “unless otherwise specified” and replace the end of the sentence to read: [The use of aluminum conductors shall be a minimum 4/0 or larger for non-residential uses for service and feeders only. Aluminum is not allowed in one-to-two family dwelling, R1, R-2, R-3, R-4 occupancy uses and any sleeping quarters.]
- (21) Section 312.8(A)(4) amend to read: [312.8 (A)(4) Mounting height. Enclosures for switches or over-current devices shall be installed so the bottom of the enclosure is not less than 2 feet (610 mm) above finish grade or working platform unless specifically listed or approved for an alternate mounting height.]
5. ~~Section 680.23(A)(4) is hereby amended by: Deleting the number "150" and inserting the number "15."~~
- (22) ~~6.~~ Section 680.23(A)(2) is hereby amended by adding the following language: [A ground fault circuit interrupter shall be installed in branch circuits that supply low voltage lighting transformers.]
- (23) Section 690.31, amend by adding to the end of the existing text to read: “The following wiring methods shall apply to AC and DC Systems.

State Law reference— Adoption by reference, 11 O.S. § 14-107.

Sec 5-402 Provisions Declared To Be Minimum Requirements

The provisions of the ~~2014~~ 2020 National Electrical Code, in their interpretation and application shall be held to be minimum requirements adopted for the promotion of public health, safety and general welfare. Wherever any of the provisions or requirements of the ~~2014~~ 2020 National Electrical Code are inconsistent with the provisions of this Code or state statutes presently existing or enacted in the future, the provisions or requirements containing the most restrictive regulation shall apply and govern.

Sec 5-411 Electrical Board Committee

This committee shall be formed to review proposed adoptions that pertain to the electrical codes. The Committee shall be composed of five members. Four of the members shall carry either a valid electrical contractor or journeyman license with the city and state or an electrical engineer licensed with the state. The fifth member shall be an electrical inspector with the City of Moore.

~~A. An electrical board is hereby created and established. The board shall consist of five members, including four appointive members and one ex officio member. The appointive members shall be appointed by the mayor and confirmed by the city council. The ex officio member shall be the electrical inspector. The appointive members shall be qualified as follows:~~

- ~~1. Two members shall be active as electrical contractors;~~
- ~~2. Two members shall be active as journeymen electricians.~~

~~The appointive members shall hold office for a term of two years and may be removed for cause. Vacancies shall be filled by appointment for the unexpired term. The appointive members may receive a compensation if so established by the city council. Two members of the board present at any meeting shall constitute a quorum for the transaction of business. The concurring vote of not less than two members is necessary to constitute an official action of the board. The ex officio member shall have voting power and shall be counted in determining a quorum.~~

~~B. The board shall, with the electrical inspector, hear, pass on and settle any disputes that may arise pertaining to the provisions of this article. The board shall prescribe a procedure and order of business for hearing applications for certificates of registration and hearing appeals from the decisions of the electrical inspector and aggrievement appeals as provided herein.~~

Severability. If any of the provisions of this ordinance are determined to be unconstitutional or unlawful by any court of competent jurisdiction, the remainder shall be severable and unaffected.

Repealer. Any ordinance or parts thereof in conflict with this section are hereby repealed.

PASSED AND APPROVED THIS 18TH DAY OF DECEMBER, 2023.

MELISSA HUNT, Vice-Mayor

ATTEST: (Seal)

VANESSA KEMP, City Clerk

APPROVED AS TO FORM AND LEGALITY:

Brian K. Miller, City Attorney

**CITY OF MOORE
ORDINANCE NO. 1042.23**

AN ORDINANCE AMENDING PART 5, CHAPTER 5, ARTICLE A, SECTIONS 5-501, 5-502 AND 5-507; ADOPTING THE 2018 INTERNATIONAL MECHANICAL CODE AS AMENDED AND MODIFIED BY THE OKLAHOMA UNIFORM BUILDING CODE COMMISSION AND ADOPTING LOCAL AMENDMENTS TO SAID CODE; ESTABLISHING MINIMUM REGULATIONS GOVERNING THE DESIGN, INSTALLATION AND CONSTRUCTION OF MECHANICAL SYSTEMS WITHIN MOORE, OKLAHOMA; PROVIDING FOR SEVERABILITY; PROVIDING FOR REPEALER.

BE IT ORDAINED BY THE CITY COUNCIL OF THE CITY OF MOORE, OKLAHOMA THAT PART 5, CHAPTER 5, ARTICLE A, SECTIONS 5-501, 5-502 AND 5-507 ARE HEREBY AMENDED TO READ AS FOLLOWS:

ARTICLE 5-5A GENERAL PROVISIONS

~~Sec 5-501 Adoption Of 2015 International Mechanical Code, As Adopted By The State Uniform Building Code Commission Pursuant To 59 OS Section 1000.23~~

Sec 5-502 Additions, Insertions And Changes

Sec 5-503 Permits

Sec 5-504 Provisions Declared To Be Minimum Requirements

Sec 5-505 Mechanical Official

Sec 5-506 Violations And Penalties

Sec 5-507 Mechanical Committee

~~Sec 5-501 Adoption Of 2015 International Mechanical Code, As Adopted By The State Uniform Building Code Commission Pursuant To 59 OS Section 1000.23~~

- (a) ~~A-~~ That certain document, being marked and designated as "~~2015~~ 2018 International Mechanical Code," as adopted by the state Oklahoma uniform building code commission pursuant to 59 O.S. § 1000.23, is hereby adopted as the mechanical code of the city, for the control of buildings and structures as herein provided, known as the "mechanical code" or "IMC"; and each and all of the regulations, provisions, penalties, conditions and terms of the ~~2015~~ 2018 International Mechanical Code are hereby referred to, adopted and made a part hereof, as if fully set out in this Code, with the additions, insertions, deletions and changes, if any, hereinafter adopted.
- (b) ~~B-~~ Subsequent revisions, modifications, codifications or editions of the code adopted herein shall become effective in the city as they are available, issued, and adopted by the city.
- ~~C-~~ ~~The provisions of the Underwriters Laboratories Inc., as to mechanical equipment and appliances, fuel supply, combustion air, chimneys and vents, duct and piping, kitchen exhaust, ventilation and energy conservation as may hereafter take place will be the~~

~~standards applicable in the city.~~

State Law reference— Adoption by reference, 11 O.S. § 14-107.

Sec 5-502 Additions, Insertions And Changes

- (a) ~~A-~~ The code adopted in section 5-501 shall be known and cited as the city's mechanical code. All persons shall comply with the provisions of the code.
- (b) ~~B-~~ The following sections are hereby revised as follows:
 - (1) ~~1-~~ Section ~~M-101.1~~ Title: These regulations shall be known as the Mechanical Code of the City of Moore, Oklahoma, hereinafter referred to as "this code."
 - (2) Section 101.2.1, amend to read: [102.8 Referenced Codes and Standards. The provisions in Appendix A: Chimney Connector Pass-Throughs” are hereby adopted and considered a part of this Code.]
 - (3) Section 103.1, delete verbiage that reads: “department of mechanical inspection” and replace it with: [City of Moore’s Community Development Inspection Division.]
 - (4) ~~2-~~ Section 106.5.2 Fee Schedule: Insert: [As provided in the city's fee schedule.]
 - (5) Section 106.5.3 amend to read: [106.5.3 Fee Refunds. The code official shall establish a policy for authorizing the refunding of fees]
 - (6) ~~3-~~ Section 108.4 Violation Penalties: Insert: Refer to City Code section 1-108, General and specific penalties; suspension or revocation of license or permit.
 - (7) ~~4-~~ Section 108.4.1 Unlawful continuance: Insert: Refer to City Code section 1-108, General and specific penalties; suspension or revocation of license or permit
 - (8) Section 108.5, delete section and amend to read: [108.5 Stop work orders. Upon notice from the Code Official, work on any mechanical system regulated by this code is being performed in a manner either contrary to the provisions of this code or dangerous or unsafe, the Code Official is authorized to issue a stop work order. The stop work order shall be in writing and shall be given to the owner of the property involved, to the owner’s authorized agent or to the person performing the work. The stop work order shall state the reason for the order and the conditions under which the cited work will be permitted to resume. Any person who shall continue any work on the mechanical system after having been served with a stop work order, except such work as the person is directed to perform to remove the violation or unsafe condition, shall be subject to penalties as prescribed law.]

(9) Section 109, delete existing language and replace with the following: [Section 109 Means of Appeal. Please reference Article 5-1D of the City of Moore’s Municipal Code.]

5. ~~Section 109.2 Membership of board: Amended to read as follows: There is hereby created a mechanical board for the city, which shall be composed of the building official of the city, who shall be ex officio chairman of the board; a second board member who shall be a licensed mechanical contractor; a third member who shall be a licensed mechanical contractor; and a fourth member who shall be a licensed mechanical journeyman. The second, third, and fourth members shall be appointed by the city council for a term of two years, and each shall serve until his successor is appointed and qualified unless sooner removed for cause. The second and third members shall have been actively engaged in such occupation for a period of not less than five years immediately preceding the date of his appointment.~~

(10) ~~6.—Section 603.8 is amended~~ add sentence to the end to read as follows:
Exceptions: a. [All ducts installed under slab shall be graded to access plenum or boot.]

Sec 5-507 Mechanical Committee

This committee shall be formed to review proposed adoptions that pertain to the mechanical and fuel gas codes. The Committee shall be composed of five members. Four of the members shall carry either a valid mechanical contractor or journeyman license with the city and state or a mechanical engineer licensed with the state. The fifth member shall be a mechanical inspector with the City of Moore.

Severability. If any of the provisions of this ordinance are determined to be unconstitutional or unlawful by any court of competent jurisdiction, the remainder shall be severable and unaffected.

Repealer. Any ordinance or parts thereof in conflict with this section are hereby repealed.

PASSED AND APPROVED THIS 18TH DAY OF DECEMBER, 2023.

ATTEST: *(Seal)*

MELISSA HUNT, Vice-Mayor

VANESSA KEMP, City Clerk

APPROVED AS TO FORM AND LEGALITY:

Brian K. Miller, City Attorney

**CITY OF MOORE
ORDINANCE NO. 1045.23**

AN ORDINANCE AMENDING PART 5, CHAPTER 9, SECTIONS 5-901 AND 5-902; ADOPTING THE 2018 INTERNATIONAL FUEL GAS CODE AS AMENDED AND MODIFIED BY THE OKLAHOMA UNIFORM BUILDING CODE COMMISSION AND ADOPTING LOCAL AMENDMENTS TO SAID CODE; ESTABLISHING MINIMUM REGULATIONS GOVERNING THE DESIGN, INSTALLATION AND CONSTRUCTION OF FUEL GAS SYSTEMS WITHIN MOORE, OKLAHOMA; PROVIDING FOR SEVERABILITY; PROVIDING FOR REPEALER.

BE IT ORDAINED BY THE CITY COUNCIL OF THE CITY OF MOORE, OKLAHOMA THAT PART 5, CHAPTER 9, SECTIONS 5-901 AND 5-902 ARE HEREBY AMENDED TO READ AS FOLLOWS:

Sec 5-901 International Fuel Gas Code 2015 Adopted

Pursuant to section 2-15 of the Charter, the council may by ordinance adopt, by reference, codes which shall be considered to have the same effect as if set out in full in the City Code. Pursuant to this authority, the council hereby ordains that a certain document, at least one copy of which is on file in the office of the city clerk, being marked and designated as the "~~2015-2018~~ International Fuel Gas Code," as adopted by the ~~state~~ Oklahoma uniform building code commission pursuant to 59 O.S. § 1000.23, is hereby adopted as the fuel gas code of the city, known as the "fuel gas code" or "IFGC"; for addressing the design and installation of fuel gas systems and gas-fired appliances as herein provided. Each and all of the regulations, provisions, penalties, conditions and terms of the International Fuel Gas Code as hereby referred to, adopted and made a part hereof, as if fully set out in this Code, with the additions, insertions, and changes, if any, as prescribed and set out herein.

State Law reference— Adoption by reference, 11 O.S. § 14-107.

Sec 5-902 Additions, Insertions And Changes

- (a) The following sections of the "International Fuel Gas Code ~~2015-2018~~" are hereby revised, deleted, or amended as set out below. Items in [] are phrases that shall be deemed inserted into the appropriate section of the International Code:

~~A. Section 108.4 Insert: [Violation] [200.00]. Delete: or by imprisonment not exceeding [number of days], or both such fine and imprisonment.~~

- (1) ~~B.~~ Section 101.1 Title: These regulations shall be known as the Fuel Gas Code of the [City of Moore, Oklahoma,] hereinafter referred to as "this code."

- (2) Section 101.3, delete and amend to read: [Section 101.3 Appendices. The provisions in appendices A, B, and C are hereby adopted and are considered a part of this Code. All other appendices are not adopted and shall not apply.]
- (3) Section 102.8, insert a sentence at the end to read: [Whenever amendments have been adopted to the referenced codes and standards, each reference to said code and standard shall be considered to reference the amendments as well. Any reference to NFPA 70 or the ICC *Electrical Code* shall mean the Electrical Code as adopted.]
- (4) Section 103.1, delete: “Department of Inspections” and replace it to read: [City of Moore’s Community Development Department].
- (5) Section 106.6.2, replace text to read: [As provided in the City’s adopted fee schedule.]
- (6) Section 106.6.3, delete section and amend to read: [The code official shall establish a policy for authorizing the refunding of fees.]
- (7) Section 108.4, delete: “of a {specify offense}, punishable by a fine of not more than {amount} dollars or by imprisonment not exceeding {number of days}, or both such fine and imprisonment.” and replace it with [as listed in the city municipal code section 1-108.]
- (8) Section 108.5, delete section and amend it to read: [*108.5 Stop work orders. Upon notice from the Code Official that work on any fuel gas system regulated by this Code is being performed in a manner either contrary to the provisions of this Code or dangerous or unsafe, the Code Official is authorized to issue a stop work order. The stop work order shall be in writing and shall be given to the owner of the property involved, to the owner’s authorized agent or to the person performing the work. The stop work order shall state the reason for the order and the conditions under which the cited work will be permitted to resume. Any person who shall continue any work on the fuel gas system after having been served with a stop work order, except such work as that person is directed to perform to remove the violation or unsafe condition shall be subject to penalties as prescribed by law.*]
- (9) Section 109, delete existing language and replace with the following: [Section 109 Board of Appeal. Please reference Article 5-1D of the City of Moore’s Municipal Code.]
- (10) Section 401.5, add a second paragraph to read: [Both ends of each section of medium pressure gas piping shall identify its operating gas pressure with an *approved* tag. The tags are to be composed of aluminum or stainless steel and the following wording shall be stamped into the tag:

"WARNING
[number] to [number] psi gas pressure

Do Not Remove"]

- (11) Section 401.7, amend to read: [401.7 Piping meter identification. Piping from multiple meter installations shall be marked with approved permanent identification with a contrasting background, durable material, engraved or pressed lettering with a minimum of 1/2 inch lettering height by the installer so that the piping system supplied by the meter is readily identifiable.]
- (12) Section 404.12, delete text: “12” and replace it with: [18]; and delete text: “except as provided in Section 404.12.1”.
- (13) Section 404.12.1, delete section.
- (14) Section 404.13, amend to read: [404.13 Trenches. The trench shall be graded so that the pipe has a firm, substantially continuous bearing on the bottom of the trench. Where over-excavated, the trench shall be backfilled to the proper grade with compacted in accordance with manufacturer’s instructions. Piping shall not be supported on rocks or blocks at any point. Rocky or unstable soil shall be over-excavated by two or more pipe diameters and brought to the proper grade with suitable compacted material.]
- (15) Section 404.13.1, amend to read: [404.13.1 Fuel/Gas shared trench. Where a fuel/gas piping is installed in a trench, sharing of the trench with electrical service, electrical feeders, electrical conduit, electrical branch circuits, water and building sewers is prohibited. The fuel/gas piping must have an 18-inch separation.]
- (16) Section 404.13.2, amend to read: [404.13.2 Warning ribbon. Underground piping shall have their location identified by a warning ribbon that is a minimum of two-inch-wide yellow background color and black wording that reads, “Caution”, “Gas Line Below”, “Buried Gas Line” or other type of wording accepted by the building official. The warning ribbon shall be placed in the trench not less than 12 inches above the underground installation.]
- (17) Section 404.13.3, amend to read: [404.13.3 Protection of footing. Trenching installed parallel to footings and wall shall comply with Section 307.5 of the International Plumbing Code.]
- (18) Section 415.1, add at the end of the section to read: [and in a neat and orderly fashion.]

Severability. If any of the provisions of this ordinance are determined to be unconstitutional or unlawful by any court of competent jurisdiction, the remainder shall be severable and unaffected.

Repealer. Any ordinance or parts thereof in conflict with this section are hereby repealed.

PASSED AND APPROVED THIS 18TH DAY OF DECEMBER, 2023.

MELISSA HUNT, Vice-Mayor

ATTEST: *(Seal)*

VANESSA KEMP, City Clerk

APPROVED AS TO FORM AND LEGALITY:

Brian K. Miller, City Attorney

**CITY OF MOORE
ORDINANCE NO. 1046.23**

AN ORDINANCE AMENDING PART 5, CHAPTER 12, SECTIONS 5-1201 AND 5-1202; ADOPTING THE 2018 INTERNATIONAL EXISTING BUILDING CODE AS AMENDED AND MODIFIED BY THE OKLAHOMA UNIFORM BUILDING CODE COMMISSION AND ADOPTING LOCAL AMENDMENTS TO SAID CODE; ESTABLISHING MINIMUM REGULATIONS GOVERNING THE DESIGN, MODIFICATION AND REMODELING OF EXISTING BUILDINGS WITHIN MOORE, OKLAHOMA; PROVIDING FOR SEVERABILITY; PROVIDING FOR REPEALER.

BE IT ORDAINED BY THE CITY COUNCIL OF THE CITY OF MOORE, OKLAHOMA THAT PART 5, CHAPTER 12, SECTIONS 5-1201 AND 5-1202 ARE HEREBY AMENDED TO READ AS FOLLOWS:

CHAPTER 5-12 EXISTING BUILDING CODE

Sec 5-1201 International Existing Building Code Adopted

Sec 5-1202 Additions, Insertions And Changes

Sec 5-1201 International Existing Building Code Adopted

Pursuant to section 2-15 of the Charter, the council may by ordinance adopt, by reference, codes which shall be considered to have the same effect as if set out in full in the City Code. Pursuant to this authority, the council hereby ordains that a certain document, at least one copy of which is on file in the office of the city clerk, being marked and designated as the "2018 International Existing Building Code" or "IEBC" as adopted by the Oklahoma uniform building code commission pursuant to 59 O.S. § 1000.23, is hereby adopted as the existing building code of the city; for addressing the design and installation of existing building systems and construction as herein provided. Each and all of the regulations, provisions, penalties, conditions and terms of the International Existing Building Code as hereby referred to, adopted and made a part hereof, as if fully set out in this Code, with the additions, insertions, and changes, if any, as prescribed and set out herein.

State Law reference— Adoption by reference, 11 O.S. § 14-107.

Sec 5-1202 Additions, Insertions And Changes

(a) The following sections of the "International Existing Building Code 2018" are hereby revised, deleted, or amended as set out below. Items in [] are phrases that shall be deemed inserted into the appropriate section of the International Code:

(1) Section 101.1 Title, insert to read: [City of Moore, Oklahoma,]

(2) Section 102.4, insert a sentence at the end to read: [Whenever amendments have been adopted to the referenced codes and standards, each reference to said code and standard shall be considered to reference the amendments as well. Any reference to

NFPA 70 or the ICC *Electrical Code* shall mean the Electrical Code as adopted.]

- (3) Section 103.1, delete: “Department of Building Safety” and replace it to read: [City of Moore’s Community Development Department].
- (4) Section 104.2.1, delete this section.
- (5) Section 109.3.3, shall read: [109.3.3 Lowest Floor Elevation. If located in a flood hazard area, the documentation of elevations required in Chapter 8 of the Land Development Code shall be submitted to the Floodplain Administrator prior to foundation inspection and final inspection.]
- (6) Section 116.4 Emergency repairs, delete section and amend to read: [Comply with City of Moore’s Municipal Code.]
- (7) Section 116.5 Cost of emergency repairs, delete section and amend to read: [Comply with City of Moore’s Municipal Code.]
- (8) Section 116.6 Hearings, delete section and amend to read: [Comply with City of Moore’s Municipal Code.]
- (9) Section 202 delete and amend “Existing Building” and “Existing Structure”:
 - a. [EXISTING BUILDING. - A building or space, where a permit was issued, an approved final inspection occurred and an occupancy was issued under a previous code edition which is at least 2 published code editions preceding the currently adopted building code.]
 - b. [EXISTING STRUCTURE. - A structure or space where a permit was issued, an approved final inspection occurred and an occupancy was issued under a previous code edition which is at least 2 published code editions preceding the currently adopted building code.]
- (10) Section 305.4.2, add a number 7 to the list of requirements to read; [7. At least one accessible family or assisted use toilet room shall be provided in accordance with Chapter 11 of the International Building Code.]
- (11) Section 401.3, delete section.
- (12) Section 405.2.5, delete section.
- (13) Section 406.1.6, add text at the end of the section to read: [, in accordance with the requirements of NFPA 70.]
- (14) Section 406.6 Panels, add and amend section to read: [406.6 Panels. Any panel that is a Federal Pacific equipment, it must be replaced and meet the adopted NEC

regulations, regardless of classification of work.]

- (15) Section 502.3, delete section.
- (16) Section 507.3, delete section.
- (17) Section 701.3, delete section.
- (18) Section 702.6, add the text within in the sentence: [International Fire Code], [National Electrical Code], [International Fuel Gas Code].
- (19) Section 802.5.1, in the first sentence delete: “a floor, such as a balcony or a loading dock” and replace it to read: [open-sided walking surfaces, including *mezzanines, equipment platforms, aisles, stairs, ramps* and landings that is].
- (20) Section 803.1 add sentence to read: [For the purpose of fire sprinkler protection and fire alarm requirements included in this section, the *work area* shall be extended to include at least the entire tenant space or spaces bounded by walls capable of resisting the passage of smoke containing the subject *work area*, and if the *work area* includes a corridor, hallway, or other exit access, then such corridor, hallway, or other exit access shall be protected in its entirety on that particular floor level.]
- (21) Section 803.2.4 replace exception and amend to read: [Exception: Supervision is not required where the Fire Code does not require such for new construction]
- (22) Section 803.3, delete and amend to read: [803.3 Standpipes. Refer to Section 1103.6 of the Fire Code for retroactive standpipe requirements.]
- (23) Section 805.2, delete exception number 1.
- (24) Section 805.3.1.2.1, in item number 2 delete the text, “new”; delete all of item number 3; in item number 5 delete the text “rooming” and replace it with [boarding].
- (25) Section 904.1, add a sentence and amend to read: [For the purpose of fire sprinkler protection and fire alarm requirements included in this section, the *work area* shall be extended to include at least the entire tenant space or spaces bounded by walls containing the subject *work area*, and if the *work area* includes a corridor, hallway, or other exit access, then such corridor, hallway, or other exit access shall be protected in its entirety on that particular floor level.]
- (26) Section 1103.3, delete section.
- (27) Section 1201.4, delete section.

(28) Section 1301.3.3, delete section.

(29) Section 1402.6, delete section.

Severability. If any of the provisions of this ordinance are determined to be unconstitutional or unlawful by any court of competent jurisdiction, the remainder shall be severable and unaffected.

Repealer. Any ordinance or parts thereof in conflict with this section are hereby repealed.

PASSED AND APPROVED THIS 18TH DAY OF DECEMBER, 2023.

MELISSA HUNT, Vice-Mayor

ATTEST: *(Seal)*

VANESSA KEMP, City Clerk

APPROVED AS TO FORM AND LEGALITY:

BRIAN K. MILLER, City Attorney

**CITY OF MOORE
ORDINANCE NO. 1043.23**

AN ORDINANCE AMENDING PART 8, CHAPTER 11, ARTICLE A, SECTION 8-1105 AND ARTICLE B, SECTIONS 8-1111 THROUGH 8-1114; ADOPTING THE 2018 INTERNATIONAL PROPERTY MAINTENANCE CODE AND ADOPTING LOCAL AMENDMENTS TO SAID CODE; ESTABLISHING MINIMUM REGULATIONS GOVERNING THE ENFORCEMENT, EVALUATION, PROCEDURE AND CONSTRUCTION OF PROPERTY MAINTENANCE WITHIN MOORE, OKLAHOMA; PROVIDING FOR SEVERABILITY; PROVIDING FOR REPEALER.

BE IT ORDAINED BY THE CITY COUNCIL OF THE CITY OF MOORE, OKLAHOMA THAT PART 8, CHAPTER 11, ARTICLE A, SECTION 8-1105 AND ARTICLE B. SECTIONS 8-1111 THROUGH 8-1114 ARE HEREBY AMENDED TO READ AS FOLLOWS:

CHAPTER 8-11 ~~EXTERIOR~~ PROPERTY MAINTENANCE CODE

ARTICLE 8-11A GENERAL

ARTICLE 8-11B ~~EXTERIOR~~ PROPERTY MAINTENANCE VIOLATIONS DEFINED CODE

ARTICLE 8-11C NOTICE AND ENFORCEMENT

ARTICLE 8-11A GENERAL

Sec 8-1101 Scope

Sec 8-1102 Responsibility

Sec 8-1103 Vacant Structures And Land

Sec 8-1104 Violations And Penalty

Sec 8-1105 Definitions

Sec 8-1105 Definitions

The following words, terms and phrases, when used in this chapter, shall have the meanings ascribed to them in this section, except where the context clearly indicates a different meaning:

Approved ~~means approved by the code official.~~

Basement ~~means that portion of a building which is partly or completely below grade.~~

Code official ~~means the city official who is charged with the administration and enforcement of this chapter, or any duly authorized representative.~~

Exterior property ~~means the open space on the premises and on adjoining property under the control of the owner or occupant of such premises.~~

Major violation means a combination of two or more minor violations occurring at the same time, or one or more violations that are determined by the code official to pose a serious threat to the

health and safety of the owner or occupant of the structure in question.

Minor violation means a singular violation of any one of the various provisions of this chapter, either through lack of maintenance or act of nature, which in and of itself does not cause a blighting problem or adversely affect the public health or safety.

~~*Occupant* means any person legally living or sleeping in a building, or having legal possession of a space within, a building.~~

~~*Owner* means any person, firm or corporation having a legal or equitable interest in the property, including the guardian, executor or administrator of the estate of such person.~~

~~*Premises* means a lot, plot, tract or parcel of land, including the buildings and structures thereon.
Structure means that which is built or constructed.~~

ARTICLE 8-11B EXTERIOR PROPERTY MAINTENANCE VIOLATIONS DEFINED CODE

- Sec 8-1111 ~~Exterior Property Areas~~ International Property Maintenance Code Adoption
- Sec 8-1112 ~~Exterior Structure General Maintenance~~ Additions, Insertions And Changes
- Sec 8-1113 Appearance
- Sec 8-1114 ~~Signage~~ Reserved
- Sec 8-1115 Enforcement

Sec 8-1111 ~~Exterior Property Areas~~ International Property Maintenance Code Adoption

- ~~A. *Grading and drainage.* All premises shall be graded and maintained to prevent the accumulation of stagnant water thereon, or within any structure located thereon, except for water detention or retention areas approved by the city.~~
- ~~B. *Rat harborage.* All structures and exterior property shall be kept free from rat infestation. Where rats are found, they shall be promptly exterminated by approved processes which will not be injurious to human health. After extermination, proper precautions shall be taken to prevent re-infestation.~~
- ~~C. *Accessory structures.* All accessory structures, including detached garages, fences and walls, shall be maintained structurally sound and in good repair. Each separate accessory structure shall be deemed a separate violation.~~

(a) Pursuant to section 2-15 of the Charter, the council may by ordinance adopt, by reference, codes which shall be considered to have the same effect as if set out in full in the City Code. Pursuant to this authority, the council hereby ordains that a certain document, at least one copy of which is on file in the office of the city clerk, being marked and designated as the "2018 International Property Maintenance Code," is hereby adopted as the property maintenance code of the city, known as the "property maintenance code" or "IPMC"; for addressing property maintenance as herein provided. Each and all of the regulations,

provisions, penalties, conditions and terms of the International Property Maintenance Code as hereby referred to, adopted and made a part hereof, as if fully set out in this Code, with the additions, insertions, and changes, if any, as prescribed and set out herein.

Sec 8-1112 Exterior Structure General Maintenance Additions, Insertions And Changes

The owner, lessee, occupant, or person or entity having charge of the property shall keep all parts of the exterior property in a clean and sanitary condition. No premises shall be in a condition that constitutes a health hazard, safety hazard, or general nuisance.

(a) The following sections of the "International Property Maintenance Code 2018" are hereby revised, deleted, or amended as set out below. Items in [] are phrases that shall be deemed inserted into the appropriate section of the International Code:

- ~~A. *Street numbers.* Each building to which a street number has been assigned shall have such number displayed in a position easily observed and readable from the public right of way. All numbers shall be at least three inches high and one half inch stroke.~~
- ~~B. *Structural members.* Any structural member of a structure which has become deteriorated or damaged to the extent that it does not serve the purpose as originally intended shall be renewed, restored, repaired, or replaced as is necessary to serve the purpose as originally intended. All structural members shall be maintained free of deterioration, and capable of safely bearing the imposed dead and live loads.~~
- ~~C. *Exterior walls and surfaces.* Exterior walls and other exterior surface materials shall be free of holes, cracks, loose or rotting boards and timbers or any other condition as to prevent rodents, rain, or dampness to the interior of the dwelling. All canopies, marquees, signs, awnings, exterior stairways, fire escapes, standpipes, exhaust ducts, porches, balconies, and similar overhanging extensions, and their supporting structures where exposed to public view, shall be maintained in good condition and shall not show evidence of ripping, tearing, or deterioration. Exterior wood surfaces, other than decay resistant woods, shall be protected from the elements and decay by painting or other protective covering or treatment. Peeling, flaking and chipped paint shall be eliminated and surfaces repainted. All metal surfaces subject to rust or corrosion shall be coated to inhibit such rust and corrosion and all surfaces with rust or corrosion shall be stabilized and coated to inhibit future rust and corrosion. Oxidation stains shall be removed from exterior surfaces. Surfaces designed for stabilization by oxidation are exempt from this requirement.~~
- ~~D. *Roofs and drainage.* The roof and flashing shall be sound, tight and not have defects which admit rain. Rain gutters, downspouts, leaders, or other means of water diversion shall be provided to collect/conduct and discharge all water from the roof and maintained so as not to leak or cause dampness in the walls, ceiling, or basements or adversely affect adjacent properties. Roof drains, gutters and downspouts shall be maintained in good repair and free from obstructions.~~

- E. ~~*Overhang extensions.* All canopies, marquees, awnings, stairways, fire escapes, standpipes, exhaust ducts, gutters and similar overhang extensions shall be maintained in good repair and be properly anchored so as to be kept in a safe and sound condition. When required, all exposed surfaces of metal or wood shall be protected from the elements and against decay by periodic application of weather coating materials, such as paint or similar surface treatment.~~
- F. ~~*Chimneys and towers.* All chimneys, cooling towers, smoke stacks, and similar appurtenances shall be maintained structurally safe, sound, and in good repair. Where required, all exposed surfaces of metal or wood shall be protected from the elements and against decay by periodic application of weather coating materials, such as paint or similar surface treatment.~~
- G. ~~*Handrails and guardrails.* Every handrail and guardrail shall be firmly fastened and capable of bearing normally imposed loads and shall be maintained in sound condition and good repair.~~
- H. ~~*Windows, skylights, doors and frames.* Windows shall be fully supplied with window glass or an approved substitute which is glazed and is without open cracks or holes, shall have sashes in good condition which fit within frames, be capable of being easily opened and held in position by hardware, and maintained so as to exclude adverse weather elements from entering the structure. Skylights, doors, and frames shall be kept in sound condition, good repair and weather tight.~~
- I. ~~*Insect screens.* All insect screens shall be tightly fitting and maintained in sound condition and good repair, free from holes, cuts, or rips.~~
- J. ~~*Exterior doors and frames.* All exterior doors, frames and hardware, including garage doors, shall be maintained in sound condition, good repair and weather tight.~~
- K. ~~*Basement, foundation, vents, and windows.* Every basement/foundation hatchway, vent or window shall be maintained in sound condition, good repair and weather tight. Foundations shall support the building at all points and shall be free of all holes and cracks as to prevent rodents, water or dampness to the interior of the building or any conditions tending to reduce the capability of the foundation to support the building.~~
- L. ~~*Porches, decks, and docks.* Every porch, deck, or dock shall be constructed and maintained so as to be free of missing, defective, rotting or deteriorated foundations, supports, floors, other members, including steps, and kept in sound condition and in good repair.~~
- M. ~~*Decorative features.* All cornices, entablatures, bell courses, corbels, terra cotta trim, wall facings, and similar decorative features shall be maintained in good repair with proper anchorage and in a safe condition.~~
- N. ~~*Sidewalks and driveways.* All sidewalks, walkways, stairs, driveways, parking spaces, parking lots and similar areas shall be kept in a proper state of repair and maintained free from hazardous conditions.~~

- (1) Section 101.1 Title, insert to read: [City of Moore, Oklahoma,]
- (2) Section 101.1.1, amend to read: [101.1.1 Appendices, amend the provisions of Appendix A of the 2018 International Property Maintenance Code.]
- (3) Section 103.1, delete: “Department of property maintenance inspections” and replace it to read: [City of Moore’s Community Development Department].
- (4) Section 103.5, insert to read: [As provided in the City’s adopted fee schedule]
- (5) Section 106.4, delete and amend to read: [106.4 Violation penalties. Any Person who shall violate a provision of this code, or fail to comply therewith, or with any of the requirements thereof, shall be prosecuted within the limits provided by state and local laws. One type of prosecution is listed in the city municipal code section 1-108. Each day that a violation continues after due notice has been served shall be deemed a separate offense.]
- (6) Section 107.2, delete and amend to read: [107.2 Form. Such notice prescribed in Section 107.1 shall be in accordance with Part 8, Chapter 8-11C of the Municipal Code for the City of Moore, Oklahoma.]
- (7) Section 108.3, delete the words: “Section 107.3” and replace to read: [Part 8, Chapter 8-3 of the City of Moore’s Municipal Code.]
- (8) Section 112.4, add to the sentence to read: [listed in the city municipal code section 1-108. Each day or occurrence that a violation continues after due notice has been served, shall be deemed a separate offense.]
- (9) Section 302.2, add sentences to section to read: [All portions of all premises shall be so graded that there is no pooling of water or recurrent entrance of water into any part of any building except where such pooling or retention of water is part of a plan approved by the city engineer. All condensate and waste cooling water shall be appropriately discharged into an approved drainage system.

Drainage swales are to be maintained by the owners of the parcels on which they are located, and at no time will anyone plant trees and/or shrubs or discharge, empty or place any material fill or waste in any swale so as to impede or divert drainage flow.]
- (10) Section 302.2.1, amend to read: [302.2.1 Gound cover erosion control. All areas shall be graded and seeded with an all-season, well maintained vegetation ground cover. Erosion controls shall be compliant with the City of Moore’s and Oklahoma Department of Environmental Quality standards.]
- (11) Section 302.3, delete section and amend to read: [302.3 Sidewalks, ~~and~~ driveways and parking lots. Sidewalks, walkways, stairs, driveways, parking spaces and similar areas shall be kept in a proper state of repair of the permanently hard surface, dust-free surface of sound construction and maintained free from hazardous conditions.

- (12) Section 302.4, delete and amend to read: [302.4 Weeds, Grass and Trash. Refer to Part 8 Health and nuisance and under Chapter 8-2 within the Municipal Code.]
- (13) Section 302.10 amend section to read: [302.10 Traffic markings. All traffic markings such as directional arrows, lane division lines, parking spaces, stop signs, fire lane, no parking, etc. shall be maintained so as to be clearly visible and easily recognized.]
- (14) Section 302.11 amend section to read: [302.11 Exterior light fixtures. Exterior lighting fixtures over stops, paths, walkways courts, drives and parking lots shall be neatly maintained in operable condition and light for sufficient period of time before and after business hours to prove for pedestrian and employee safety and properly aimed so as not to shine on adjacent properties. Refer to Municipal Code Part 5; Chapter 5-8.]
- (15) Section 302.12 amend section to read: [302.12 Mosquito infestation. All structures and exterior property shall be kept free of the accumulation of stagnant water by any means, which may yield the potential for serving as a breeding ground for mosquitoes.]
- (16) Section 302.13 amend section to read: [302.13 Bollards/vehicle protection. All bollards or collision protection structure shall be free of damage, protected against rust and kept in good condition and remain effective in protecting people and property.]
- (17) Section 304.14, insert the dates to read: [February 15] and [November 15].
- (18) Section 304.15, amend to read: [304.15 Doors. Exterior doors, door assemblies, operator system, if provided, garage doors and hardware shall be maintained in good, sound and weather tight condition. Locks at all entrances to dwelling units and sleeping units shall tightly secure the door. Locks on means of egress doors shall be in accordance with Section 702.3]
- (19) Section 304.17, in the first sentence delete: “that is openable” and add at the end of the sentence to read: [rain and surface drainage water. If an openable window is in place, it shall be supplied with insect screens.]
- (20) Section 304.20, amend to read: [304.20 Porches, decks, docks. Every porch, deck or dock shall be constructed and maintained so as to be free of missing, defective, rotting or deteriorated foundations, supports, floors, other members, including steps and kept in sound condition and in good repair.]
- (21) Section 310, amend fences and walls section to read:

[SECTION 310 FENCES AND WALLS

- a. Section 310.1 General. All fences, masonry walls or similar structures shall be maintained in an appropriate manner that complies with the City’s Land Development Code, International Building Code, International Residential

Code and International Property Maintenance Code.

b. Section 310.2 Maintenance. All fences, masonry walls or similar structures shall be anchored firmly in the ground, shall be constructed in a workmanlike manner and maintained in that same manner so that such approved fences, masonry walls, or similar structures shall always be in the state of good structural repair. If any fence, masonry wall or similar structure is found not to be in the state of good structural repair, it shall be removed, replace or repaired. The following items, being found singularly or collectively, shall be used in determining a fence that is in violation of this section:

1. Missing or broken panels;
2. Lean posts being used to keep the fence erect;
3. Patches made to the fence that are not made of the same original fence materials;
4. Three or more broken or missing slats within a panel;
5. Broken fence post(s);
6. Upright fence post(s) when no fence panel(s) or other horizontal fence material is erected;
7. Leaning panel(s), fence material or fence post; or
8. Comply with Chapter 6 of the City of Moore's Land Development Code

c. Section 310.3 Materials. Fences and/or walls and shall be constructed of treated wood, iron, decorative aluminum, stone , brick or decorative block. When construction materials are designed or manufactured to remain untreated, all fences shall be treated periodically with paint or chemicals so as to retard deterioration.

d. Section 310.4 Hardware. Exterior components, assemblies, brackets, anchoring, poles, braces, operator systems shall be maintained in good condition, proper workmanlike manner, and installed in accordance with any adopted code or manufacture's instructions.]

(22) Section 311, amend signage section to read:

[SECTION 311 SIGNAGE

a. Section 311 General. All signs, billboards, ground sign, wall sign, roof sign,

illuminated sign, projection sign, and temporary sign that include any announcement, declaration, demonstration, display illustration or insignia used to advertise or to promote the interest of any person when the same is placed out of doors in view of the general public shall be properly anchored, capable of safely supporting the imposed dead and live loads, be kept in a proper state of repair and maintained free from hazardous conditions.

- b. Section 311.1 Sign maintenance. All signage and incidental landscaping and/or lighting shall be maintained in good condition and shall not show evidence of deterioration. Neither lighting nor signage shall be permitted to be posted on trees, public information or traffic signs or utility poles.
- c. Section 311.2 Placement. No sign or other advertising structure shall be erected on public property or at the intersection of any streets in such a manner as to obstruct free and clear vision; or at any location where, by reason of the position, shape or color, it may interfere with, obstruct the view or be confused with any authorized traffic sign, signal or device.
- d. Section 311.3 Visibility triangle. All signage shall be located outside of all visibility triangles at intersections and ingress/egress points and shall not be located in such a manner as to constitute a traffic hazard, pedestrian hazard or safety hazard.
- e. Section 311.3.1 Obstructing view at intersection. No sign or incidental landscaping, fencing, lighting, plant, etc. having a height in excess of 3 feet above the elevation of the curb or crown of the adjacent roadway, whichever is lower, shall be maintained upon any corner lot adjacent to a street intersection within the city. The triangle area is to be measured from the intersection of the roadside lot lines of a corner lot. The measurement shall follow along the two common property lines and roadside lot lines of the intersection, that measures 25 feet in length. The visibility triangle shall interconnect the two property/roadside lot lines and connect to form a right triangle. The enclosed right triangle area shall establish the visibility triangle.]

(23) Section 506.4, amend sewage backflow to read: [506.4 Sewage backflow. There shall be two directional cleanouts with a backwater valve in between the two directional cleanouts near the junction of the building drainage and building sewer. The two directional cleanouts and backwater valve shall be outside the building wall, provided that it is brought up to finish grade. Backwater valves shall be subject to the following specifications:

- a. The installation of backwater devices shall be in accordance with lawful requirements of the administrative authority.
- b. Shall be installed in the building drain branch which receives only the discharge from fixtures connected to branches which are located below ground level.
- c. All bearing parts of corrosion-resistant materials.

- d. Working parts shall be readily accessible for service and repairs; and
- e. Constructed so a mechanical seal against backflow will be provided.]

(24) Section 605.5, amend to read: [Section 605.5 Panel. Any existing or proposed use of a Federal Pacific equipment is prohibited and must be replaced to meet the adopted and applicable codes.]

Sec 8-1113 Appearance

All buildings and the exterior of all premises shall be properly maintained to achieve a presentable appearance and to avoid blighting effects and hazardous conditions.

- (a) ~~A- Exterior space.~~ The exterior open space around each structure shall be maintained or improved so as to provide for:
 - (1) ~~1-~~ The immediate diversion of water away from buildings and proper drainage of the lot;
 - (2) ~~2-~~ Grass, plantings, or other suitable ground cover to prevent soil erosion which is or may become detrimental to the structures, lot use or adjacent lots and structures; and
 - (3) ~~3-~~ Sidewalks, walkways, parking areas, driveways and exterior steps which are of a permanently hard, dust-free surface of sound construction, and properly maintained.
- (b) ~~B- Buffer and screening requirements.~~ When commercial or industrial property is being developed, and it abuts property zoned or used for residential purposes, a six-foot tall buffer shall be constructed of an appropriate mounding, fencing, or vegetative material, along the entire length of any abutting side or rear yard. Screen plantings shall have a minimum height of five feet and should be of such size, species, and spacing as can reasonably be expected to produce an opaque six-foot screen within three years.
- (c) ~~C- Vegetative ground cover required.~~ All green areas shall be graded and seeded with an all- season, well maintained vegetative ground cover.
- ~~A- Fences and walls.~~ All fences, retaining walls, or similar structures shall be anchored firmly in the ground, shall be constructed in a workmanlike manner and maintained in that same manner so that such approved fences, retaining walls, or similar structures shall always be in the state of good structural repair. If any fence, retaining wall, or similar structure is found not to be in the state of good structural repair, it shall be removed, replaced, or repaired, as required. Except when constructed of materials that have been designed or manufactured to remain untreated, all fences shall be treated periodically with paint or chemicals so as to retard deterioration. Fences and/or walls shall be constructed of wood, iron, decorative aluminum, stone, brick, or

decorative block. Retaining walls shall be constructed of stone, decorative wall systems, brick, or wood. The following items, being found singularly or collectively, shall be used in determining a fence that is in violation of this section:

1. ~~Missing or broken panels;~~
 2. ~~Lean posts being used to keep the fence erect;~~
 3. ~~Patches made to the fence that are not made of the same original fence material;~~
 4. ~~Three or more broken or missing slats within a panel;~~
 5. ~~Broken fence posts;~~
 6. ~~Upright fence posts when no fence panels or other horizontal fence material is erected;~~
 7. ~~Leaning panels, fence material or fence posts.~~
- ~~B. *Yards.* All yards, courts, and lots shall be kept free of noxious weeds, overgrown grasses, debris, and other materials which may cause a fire, health or safety hazard, or general unsightliness.~~
- ~~C. *Hazards.* Hazards and unsanitary conditions shall be eliminated.~~
- ~~D. *Grading.* All premises shall be graded and maintained to prevent the erosion of soil and to prevent the accumulation of water thereon, or within any structure located thereon. *Drainage.* All portions of all premises shall be so graded that there is no pooling of water or recurrent entrance of water into any part of any building except where such pooling or retention of water is part of a plan approved by the city engineer. All condensate and waste cooling water shall be appropriately discharged into an approved drainage system.~~
- ~~E. *Drainage swales.* Swales are to be maintained by the owners of the parcels on which they are located, and at no time will anyone plant trees and/or shrubs or discharge, empty, or place any material fill or waste into any swale so as to impede or divert drainage flow.~~
- ~~F. *Traffic markings.* All traffic markings such as directional arrows, lane division lines, parking space lines, stop signs, etc., shall be maintained so as to be clearly visible and easily recognized.~~
- ~~G. *Exterior light fixtures.* Exterior lighting fixtures over steps, paths, walkways, courts, drives and parking lots shall be neatly maintained in operable condition and lighted for sufficient periods of time before and after business hours to provide for pedestrian and employee safety and properly aimed so as not to shine on adjacent properties (per local zoning regulation).~~
- ~~H. *Driveways and walkways.* All driveways, walkways, stairs, parking spaces, parking lots and similar areas shall be kept in a proper state of repair, and maintained free from hazardous~~

conditions.

- ~~I. *Rodent harborage.* All structures and exterior property shall be kept free from rodent harborage and infestation. Where rodents are found, they shall be promptly exterminated by approved processes which will not be injurious to human health. After extermination, proper precautions shall be taken to eliminate rodent harborage and prevent re-infestation~~
- ~~J. *Mosquito infestation.* All structures and exterior property shall be kept free of the accumulation of stagnant water by any means, which may yield the potential for serving as a breeding ground for mosquitoes.~~

Sec 8-1114 Signage Reserved.

- ~~A. *Sign maintenance.* All signage and incidental landscaping and/or lighting shall be maintained in good condition and shall not show evidence of deterioration. Neither lighting nor signage shall be permitted to be posted on trees or utility poles.~~
- ~~B. *Visibility triangles.* All signage shall be located outside of all visibility triangles at intersections and ingress/egress points, and shall not be located in such a manner as to constitute a traffic or safety hazard.~~

Severability. If any of the provisions of this ordinance are determined to be unconstitutional or unlawful by any court of competent jurisdiction, the remainder shall be severable and unaffected.

Repealer. Any ordinance or parts thereof in conflict with this section are hereby repealed.

PASSED AND APPROVED THIS 18TH DAY OF DECEMBER, 2023.

MELISSA HUNT, Vice-Mayor

ATTEST: (Seal)

VANESSA KEMP, City Clerk

APPROVED AS TO FORM AND LEGALITY:

Brian K. Miller, City Attorney

**CITY OF MOORE
ORDINANCE NO. 1044.23**

AN ORDINANCE AMENDING PART 13, CHAPTER 1, ARTICLE A, SECTION 13-101 AND 13-103; ADOPTING THE 2018 INTERNATIONAL FIRE CODE AS AMENDED AND MODIFIED BY THE OKLAHOMA UNIFORM BUILDING CODE COMMISSION AND ADOPTING LOCAL AMENDMENTS TO SAID CODE; ESTABLISHING MINIMUM REGULATIONS GOVERNING THE DESIGN, INSTALLATION AND CONSTRUCTION OF BUILDING FIRE PROTECTION WITHIN MOORE, OKLAHOMA; PROVIDING FOR SEVERABILITY; PROVIDING FOR REPEALER.

BE IT ORDAINED BY THE CITY COUNCIL OF THE CITY OF MOORE, OKLAHOMA THAT PART 13, CHAPTER 1, ARTICLE A, SECTION 13-101 AND 13-103 ARE HEREBY AMENDED TO READ AS FOLLOWS:

ARTICLE 13-1A GENERAL PROVISIONS

Sec 13-101 Adoption Of The ~~2015~~ International Fire Code, ~~As Amended And Modified By The State Uniform Building Code Commission Pursuant To 59 OS Section 1000.23~~

Sec 13-102 Fire Prevention

Sec 13-103 ~~Adoption Of Specified Appendices~~ Reserved

Sec 13-104 Establishment Of Limits Of Districts In Which Storage Of Explosives And Blasting Agents Is To Be Prohibited

Sec 13-105 Establishment Of Limits Of Districts In Which Storage Of Flammable Liquids In Outside Aboveground Tanks Is To Be Prohibited

Sec 13-106 Establishment Of Limits In Which Bulk Storage Of Liquefied Petroleum Gases Is To Be Restricted

Sec 13-107 Provisions Declared To Be Minimum Requirements

Sec 13-108 Modifications Of The Fire Prevention Code Authorized

Sec 13-109 New Materials, Processes Or Occupancies Which May Require Permits

Sec 13-110 Appeals

Sec 13-111 Life Safety Code Adopted

Sec 13-112 Certificate Of Fitness

~~Sec 13-101 Adoption Of The 2015 International Fire Code, As Amended And Modified By The State Uniform Building Code Commission Pursuant To 59 OS Section 1000.23~~

- (a) ~~A-~~ There is hereby adopted by the city for the purpose of prescribing regulations governing conditions hazardous to life and property from fire or explosion that certain code known as the ~~2015~~ 2018 International Fire Code, as amended and modified by the state Oklahoma uniform building code commission pursuant to 59 O.S. § 1000.23, the whole thereof, save and except such portions as are hereinafter deleted, modified or amended; of which code not less than one copy has been and is filed in the office of the city clerk. The International Fire Code, as amended, is hereby adopted and incorporated as if set out at length herein, and shall be incorporated and considered as a part of this Code.

(b) ~~B~~. The following additions, amendments, or deletions are made to the fire code adopted herein:

- (1) Section 101.1. Insert: [The City of Moore, Oklahoma]
- (2) Section 101.2.1, delete and amend to read: [101.2.1 Appendices. The provisions in Appendix B, C, D, E, and F are hereby adopted and considered a part of this Code.]
- (3) Section 102.1, add text at the end of number 3 to read: [or in specific sections of this code.]
- (4) Section 103.1, delete “department of” and add text after fire prevention to read: [division of Moore Fire Department]
- (5) Section 105.7.26, add section to read: [105.7.26 Electronic access control systems. Construction permits are required for the installation or modification of an electronic access control system, as specified in Chapter 10. A separate construction permit is required for the installation or modification of a fire alarm system that may be connected to the access control system. Maintenance performed in accordance with this code is not considered a modification and does not require a permit.]
- (6) Section 106.6, add section to read: [106.6 Unauthorized cover up fee. Any work concealed without first obtaining the required inspection shall be assessed a fee as established by the city fee schedule.]
- (7) Section 107.5, add section to read: [107.5 Re-inspection Fee. A fee as established by city council resolution may be charged when:
 - a. 1. The inspection called for is not ready when the inspector arrives;
 - b. 2. No building address or permit card is clearly posted;
 - c. 3. City approved plans are not on the job site available to the inspector;
 - d. 4. The building is locked or work otherwise not available for inspection when called;
 - e. 5. The job site is red-tagged twice for the same item;
 - f. 6. The original red tag has been removed from the job site.
 - g. 7. A second inspection is requested or required due to the lack of proper installation, construction or material.

Any re-inspection fees assessed shall be paid before any more inspections are made

on that job site.]

Section 109.4. Insert: Misdemeanor, \$500.00; delete: or by imprisonment not exceeding 10 days, or both such fine and imprisonment

(8) Section 110.4, delete and amend to read: [110.4 Violation penalties. Persons who shall violate a provision of this code or shall fail to comply with any of the requirements thereof or who shall erect, install, alter or repair or do work in violation of the approved construction documents or directive of the fire code official, or of a permit or certificate issued under the provisions of this code shall be guilty as listed in the city municipal code section 1-108. Each day that a violation continues after due notice has been served shall be deemed a separate offense.]

Section 111.4. Delete: less than [amount] dollars and insert: more than five hundred (\$500.00) dollars

(9) Section 202, add and amend definitions to read:

- a. [ASSISTED LIVING FACILITIES. A building or part thereof housing persons, on a 24-hour basis, who because of age, mental disability or other reasons, live in a supervised residential environment which provides personal care services. The occupants are capable of responding to an emergency situation without physical assistance from staff.]
- b. [DEFEND IN PLACE. A method of emergency response that engages building components and trained staff to provide occupant safety during an emergency. Emergency response involves remaining in place, relocating within the building, or both, without evacuating the building.]
- c. [FIRE WATCH. A temporary measure intended to ensure continuous and systematic surveillance of a building or portion thereof by one or more qualified individuals or standby personnel when required by the fire code official, for the purposes of identifying and controlling fire hazards, detecting early signs of unwanted fire, raising an alarm of fire and notifying the fire department.]
- d. [FLEX SPACE. A room or space that can fulfill multiple purposes and does not define the actual use of a room or space. A flexible area that varies in both shape and function. Flex space or the use of other terms such as bonus room/area, additional space, or any other terminology that does not define the exact use shall be constructed to the most restrictive zoning use allowed by the adopted Land Development Code for the City of Moore. Bathrooms, kitchens, or any other plumbing fixture, piping or any accessible plumbing system is not allowed within this room/space, except fire sprinkler protection system only.]

- e. [REPAIR GARAGE. A building, structure or portion thereof used for servicing or repairing motor vehicles. This occupancy shall also include garages involved in minor repair, modification and servicing of motor vehicles for items such as lube changes, inspections, windshield repair or replacement, shocks, minor part replacement, and other such minor repairs.]
- f. [SELF-SERVICE STORAGE FACILITY. Real property designed and used for the purpose of renting or leasing individual storage spaces to customers for the purpose of storing and removing personal property on a self-service basis. Bathrooms, kitchens, or any other plumbing fixture or any accessible plumbing system, other than for fire protection, is not allowed within this room/space.]

(10) Section 307.4, delete the number “50” and replace it with [300]; delete the first word “structure” and replace it with [property line]

(11) Section 308.1.4, delete and amend to read: [308.1.4 Open-flame Cooking Devices. Open-flame cooking devices, charcoal grills and other similar devices used for cooking shall not be located or used on combustible balconies, decks, or within 10 feet (3048 mm) of combustible construction.]

a. Section 308.1.4, Exception number 1, add text at the end to read: [except that LP-gas containers are limited to a water capacity not greater than 20 pounds (9.08 kg) LP-gas capacity] with an aggregate LP-gas capacity not to exceed 100 pounds (5 containers).]

b. Section 308.1.4, Exception number 2, delete and amend to read: [2. Where buildings, balconies and decks are protected by an approved *automatic sprinkler system*, except that LP-gas containers are limited to a water capacity not greater than 20 pounds (9.08 kg) LP-gas capacity, with an aggregate LP-gas capacity not to exceed 40 lbs. (2 containers).]

~~Section 308.1.4. Delete Exception 2: Where buildings, balconies and decks are protected by an automatic sprinkler system; delete Exception 3.: LP-gas cooking devices having LP-gas container with a water capacity not greater than 2 1/2 pounds [nominal 1 pound (0.45 kg) LP-gas capacity]~~

c. Section 308.1.4, Exception number 3, keep verbiage as read in the adopted code.

(12) Section 308.1.6.2, Exception Number 3, delete and amend to read: [3. Torches or flame-producing devices in accordance with Section 906 and the person doing the burning shall remain on the premises 1 hour after the torch or flame-producing device is utilized.]

- (13) Section 311.5, delete at the beginning of the sentence that reads: “any” and replace it to read: [The fire code official is authorized to require marking of any]
- (14) Section 403.5, add a sentence to read: [A diagram depicting two evacuation routes shall be posted in a conspicuous location in each classroom.]
- (15) Section 404.2.2, add number 8 to read: [8. Fire extinguishing system controls.]
- (16) Section 405.4, add at the beginning to read: [The fire code official may require an evacuation drill at any time.]
- (17) Section 503.1, add text at the end of the section to read: [or when approved by the fire code official in accordance with Appendix D.]
- (18) Section 503.2.1, remove the number “20” and replace it with [24]; remove “13 feet 6 inches” and replace it with [14 feet (4267 mm). Fire apparatus access roads shall not be located within 10 feet (3048 mm) of any building.]
- (19) Section 503.2.2, add verbiage to read: [and vertical clearances].
- (20) Section 503.3, delete and amend to read: [503.3 Marking. Striping, signs, or other markings, when approved by the *fire code official*, shall be provided for fire apparatus access roads to identify such roads or prohibit the obstruction thereof. Striping, signs and other markings shall be maintained in a clean and legible condition at all times and be replaced or repaired when necessary to provide adequate visibility.
- a. 1 Striping – Fire apparatus access roads shall be continuously marked by painted lines of red traffic paint six inches (6”) in width to show the boundaries of the lane. The words “NO PARKING FIRE LANE” or “FIRE LANE NO PARKING” shall appear in four inch (4”) white letters at 25 feet intervals on the red border markings along both sides of the fire lanes. Where a curb is available, the striping shall be on the vertical face of the curb and on the horizontal top portion of the curb.
- b. 2 Signs – Signs shall read “NO PARKING FIRE LANE” or “FIRE LANE NO PARKING” and shall be 12” wide and 18” high. Signs shall be high reflective painting with a white background with letters and borders in red, using not less than 2” lettering. Signs shall be permanently affixed to a stationary post and the bottom of the sign shall be six feet, six inches (6’6”) above finished grade. Signs shall be spaced not more than fifty feet (50’) apart along both sides of the fire lane. Signs may be installed on permanent buildings or walls or as approved by the Fire Marshal.
- (21) Section 505.1, delete and amend to read: [505.1 Address Identification. New and

existing buildings shall be provided with approved address identification. The address identification shall be legible and placed in a position that is visible from the street or road fronting the property. Address identification characters shall contrast with their background. Address numbers shall be Arabic numbers or alphabetical letters. Numbers shall not be spelled out. Each character shall be not less than 6 inches (152.4 mm) high with a minimum stroke width of 1/2 inch (12.7 mm). Where required by the fire code official, address numbers shall be provided in additional approved locations to facilitate emergency response. Where access is by means of a private road, buildings do not immediately front a street, and/or the building cannot be viewed from the public way, a monument, pole or other sign with approved 12 inch (152.4 mm) height building numerals or addresses and 4 inch (101.6 mm) height suite/apartment numerals of a color contrasting with the background of the building or other approved means shall be used to identify the structure. Building Numerals or addresses shall be posted on a minimum 20 inch (508 mm) by 30 inch (762 mm) high reflective background on border. Address identification shall be maintained.]

- (22) Section 507.3, add sentence at the end to read: [or when approved by the fire code official in accordance with Appendix B.]
- (23) Section 507.5, add sentence at the end to read: [or when approved by the fire code official in accordance with Appendix C.]
- (24) Section 507.5.4, delete and amend to read:[507.5.4 Obstruction. Unobstructed access to fire hydrants shall be maintained at all times. Posts, fences, vehicles, growth, trash, storage and other materials or objects shall not be placed or kept near fire hydrants, fire department inlet connections or fire protection system control valves in a manner that would prevent such equipment or fire hydrants from being immediately discernible. The fire department shall not be deterred or hindered from gaining immediate access to fire protection equipment or fire hydrants.]
- (25) Section 509.1.2, add section to read: [509.1.2 Sign Requirements. Unless more stringent requirements apply, lettering for signs required by this section shall have a minimum height of 4 inches (101.6 mm) when located inside a building and 6 inches (152.4 mm) when located outside, or as approved by the *fire code official*. The letters shall be of a color that contrasts with the background.]
- (26) Section 705.2.1.1, add section to read: [705.2.1.1 Marking and identification. Where there is an accessible concealed floor, floor-ceiling or attic space, fire walls, fire barriers, fire partitions, smoke barriers and smoke partitions or any other wall required to have protected openings or penetrations shall be effectively and permanently identified with signs or stenciling in the concealed space. Such identification shall:

- a. 1. Be located continuously and withing 15 feet (4,572 mm) of the end of each wall and at intervals not exceeding 30 feet (9,144 mm) measured horizontally along the wall or partition.
 - b. 2. Include lettering not less than 3 inches in height with a minimum 3/8 inch stoke in a contrasting color incorporating the suggested wording, “FIRE AND/OR SMOKE BARRIER – PROTECT ALL OPENINGS,” or other wording.
 - c. 3. For this project shall have the letter a minimum of 36” from the bottom of the wall and 36” from the top or peak of the wall.]
- (27) Section 705.2.1.2, add section to read: [705.2.1.2 Fire Wall Marking and identification. A four foot long and a four inch wide reflective strip shall adhere or anchor to the exterior wall facing the fire apparatus lane, public street, private street or parking aisle to identify the location of a fire wall. The placement must begin a minimum of two feet under the eave or top of the parapet wall and a maximum of eight feet under the eave or top of the parapet.]
- (28) Section 901.7, add verbiage in the first sentence to read: [or in the event of an excessive number of activations].
- (29) Section 903.1.1, in the first sentence delete: “instead of” and add verbiage [in addition to]; at the end of the sentence delete: “and” and replace it to read: [or as].
- (30) Section 903.2.9, add condition number 6 to read: [6. A Group S-1 fire area used for the self-service storage facility exceeds 2,500 square feet (232 m²).]
- (31) Section 903.3.1.2.3, delete and amend to read: [Section 903.3.1.2.3 Attached Garages and Attics. Sprinkler protection is required in attached garages, and in the following attic spaces:]
- (32) Section 903.3.1.2.3, number 3, delete and amend to read: [3. Attic spaces of buildings that are two or more stories in height above grade plane or above the lowest level of fire department vehicle access.]
- (33) Section 903.3.1.2.3, number 4, add text to read: [or 3].
- (34) Section 903.3.1.4 add to read: [903.3.1.4 Freeze protection. Freeze protection systems for automatic fire sprinkler systems shall be in accordance with the requirements of the applicable referenced NFPA standard and this section.
- a. 903.3.1.4.1 Attics. Only dry-pipe, reaction, or listed antifreeze automatic fire sprinkler systems shall be allowed to protect attic spaces.

Exception: Wet-pipe fire sprinkler systems shall be allowed to protect non-ventilated attic spaces where:

1. The attic sprinklers are supplied by a separate floor control valve assembly to allow ease of draining the attic system without impairing sprinklers throughout the rest of the building, and
2. Adequate heat shall be provided for freeze protection as per the applicable referenced NFPA standard, and
3. The attic space is a part of the building's thermal, or heat, envelope, such that insulation is provided at the roof deck, rather than at the ceiling level.

b. 903.3.1.4.2 Heat trace/insulation. Heat trace/insulation shall only be allowed where approved by the fire code official for small sections, not to exceed five feet, of large diameter water-filled pipe.]

(35) Section 903.4.2, add a second paragraph to read: [The alarm device required on the exterior of the building shall be a weatherproof horn/strobe notification appliance with a minimum 75 effective intensity strobe rating, installed as close as practicable to the fire department connection.]

(36) Section 905.4, change items 1, 2, 3 and 5; and amend item 7: Item 1 – Delete: “interior”; Item 2 – Delete all of the exception; Item 3 – Delete all of the exception; Item 5 – Insert: [each standpipe shall be provided with a two-way] and delete: “shall be” and “interior”; Item 7 – Amend the following to read: [When required by this Chapter, standpipe connections shall be placed adjacent to all required exits to the structure and at two hundred feet (200') intervals along major corridors thereafter, or as otherwise approved by the fire code official.]

(37) Section 907.4.2.7 amend to read as follows: [907.4.2.7 Type. Manual alarm initiating devices shall be an approved double action type.]

(38) Section 910.2.3 amend to read as follows: [910.2.3 Group H. Buildings and portions thereof used as a Group H occupancy as follows:

a. 1. In occupancies classified as Group H-2 or H-3, any of which are more than 15,000 square feet (1394 m²) in single floor area.

Exception: Buildings of noncombustible construction containing only noncombustible materials.

b. 2. In areas of buildings in Group H used for storing Class 2, 3, and 4 liquid and solid oxidizers, Class 1 and unclassified detonable organic peroxides, Class 3 and 4 unstable (reactive) materials, or Class 2 or 3 water-reactive

materials as required for a high-hazard commodity classification.

Exception: Buildings of noncombustible construction containing only noncombustible materials.]

(39) Section 912.3.1 amend section to read as follows: [912.3.1 Storz. Minimum connection for a storz shall be five inches.

(40) Section 913.2.1.1 amend to read as follows: [913.2.1.1 Fire Pump Room Access. When located on the ground level at an exterior wall, the fire pump room shall be provided with an exterior fire department access door that is not less than 3 ft. in width and 6 ft. – 8 in. in height, regardless of any interior doors that are provided. A knox box shall be provided at this door, as required by IFC Section 506.1.

Exception: When it is necessary to locate the fire pump room on other levels or not at an exterior wall, the corridor leading to the fire pump room access from the exterior of the building shall be provided with equivalent fire resistance as that required for the pump room, or as approved by the *fire code official*. Access keys shall be provided in the knox box as required by IFC Section 506.1.]

(41) Section 914.3.1.2, delete the number “420” and replace it with [120].

(42) Section 1103.5.5 add section to read: [1103.5.5 Spray Booths and Rooms. Existing spray booths and spray rooms shall be protected by an approved automatic fire-extinguishing system in accordance with Section 2404.]

State Law reference— Adoption by reference, 11 O.S. § 14-107.

Sec 13-103 ~~Adoption Of Specified Appendices~~ Reserved

~~The following appendices to the 2015 International Fire Code are adopted and incorporated by reference and made a part hereof as if fully set forth herein: Appendix B, Appendix C, and Appendix D.~~

Severability. If any of the provisions of this ordinance are determined to be unconstitutional or unlawful by any court of competent jurisdiction, the remainder shall be severable and unaffected.

Repealer. Any ordinance or parts thereof in conflict with this section are hereby repealed.

PASSED AND APPROVED THIS 18TH DAY OF DECEMBER, 2023.

MELISSA HUNT, Vice-Mayor

ATTEST: *(Seal)*

VANESSA KEMP, City Clerk

APPROVED AS TO FORM AND LEGALITY:

Brian K. Miller, City Attorney

BID RESULTS

To: Whitney Wathen
Assistant Parks Director, City of Moore
700 S. Broadway
Moore, OK 73160

From: Hannah Belew, PLA, ASLA
Senior Design Associate, LAUD Studio
220 NW 13th Street Suite 1
Oklahoma City, OK 73103

November 7th, 2023

Re: Veterans Memorial Park Trail Enhancements - Bid 2024-006 Results Recommendation

Mr. Wathen,

Bids were received from five general contractors on the above referenced project on November 2nd, 2023 at 3:15 pm in the City of Moore Council Chamber Room.

A summation of the five acceptable bids:

	Base	Add Alt 1	Total
Greenshade Trees, LLC	\$488,705.54*	\$73,504.31*	\$562,209.85*
Rudy Construction Co.	\$496,740.50	\$88,180.60	\$584,921.10
Weldon Construction Company, LLC	\$503,175.91*	\$86,976.00*	\$590,151.91*
Wynn Construction Co., Inc.	\$568,935.60	\$102,197.60	\$671,133.20
Downey Contracting, LLC	\$696,665.00	\$112,133.75	\$808,798.75*

*Bid adjusted for scrivener's error and differ from contractor's submitted bidsheet.

Based upon review of the above, the apparent low bidder for the Veterans Memorial Park Trail Enhancements - Bid 2024-006 is Greenshade Trees, LLC with a total bid of \$562,209.85. The bid tabulation information for each bidder is attached.

LAUD Studio recommends that you negotiate a contract with Greenshade Trees, LLC for the Base Bid and Add Alternate 1 provided the following site furnishings are deducted from the bid - benches, trash receptacles, and games tables. The City of Moore will purchase and install site furnishings for the project. The adjusted total bid for Greenshade Trees, LLC without site furnishings is **\$512,340.67**.

With the previously stated scope revision, comparisons were made across all five bidders, and Greenshade Trees, LLC remains the apparent low bidder.

Sincerely,



Hannah Belew, PLA, ASLA
Senior Design Associate, LAUD Studio LLC

ENCLOSURES/ATTACHMENTS

A. Bid Tabulation for the Veterans Memorial Park Trail Enhancements - Bid 2024-006 (5 pages)

LAUD

220 NW 13th Street Suite 1 Oklahoma City, OK 73103

1 of 1

BID TAB
Veteran's Memorial Park Trail Enhancements, BID NO, 2024-006

BASE BID

DIVISION 1 - GENERAL

ITEM#	EST. QTY.	UNIT	DESCRIPTION	Wynn Construction		Rudy Construction		Downey Contracting		Greenshade Trees		Weldon Construction	
				UNIT PRICE	ITEM TOTAL	UNIT PRICE	ITEM TOTAL	UNIT PRICE	ITEM TOTAL	UNIT PRICE	ITEM TOTAL	UNIT PRICE	ITEM TOTAL
1.01	1	LS	General Conditions	\$ 130,000.00	\$ 130,000.00	\$ 60,000.00	\$ 60,000.00	\$ 195,000.00	\$ 195,000.00	\$ 24,442.01	\$ 24,442.01	\$ 83,000.00	\$ 83,000.00
			Unit Price in Words	Dollars									

DIVISION 2 - DEMOLITION

ITEM#	EST. QTY.	UNIT	DESCRIPTION	Wynn Construction		Rudy Construction		Downey Contracting		Greenshade Trees		Weldon Construction	
				UNIT PRICE	ITEM TOTAL	UNIT PRICE	ITEM TOTAL	UNIT PRICE	ITEM TOTAL	UNIT PRICE	ITEM TOTAL	UNIT PRICE	ITEM TOTAL
2.01	915	SY	Demo Concrete Sidewalk	\$ 20.00	\$ 18,300.00	\$ 15.00	\$ 13,725.00	\$ 8.00	\$ 7,320.00	\$ 14.21	\$ 13,002.15	\$ 17.71	\$ 16,204.65
			Unit Price in Words	Dollars									
2.02	6	LF	Demo Curbs & Gutters	\$ 80.00	\$ 480.00	\$ 30.00	\$ 180.00	\$ 20.00	\$ 120.00	\$ 27.61	\$ 165.66	\$ 12.65	\$ 75.90
			Unit Price in Words	Dollars									
2.03	29	LF	Demo Saw Cutting Concrete	\$ 50.00	\$ 1,450.00	\$ 10.00	\$ 290.00	\$ 10.00	\$ 290.00	\$ 16.09	\$ 466.61	\$ 2.53	\$ 73.37
			Unit Price in Words	Dollars									
2.04	1	LS	Salvage Miscellaneous Items	\$ 1,800.00	\$ 1,800.00	\$ 7,500.00	\$ 7,500.00	\$ 3,000.00	\$ 3,000.00	\$ 1,620.45	\$ 1,620.45	\$ 1,265.00	\$ 1,265.00
			Unit Price in Words	Dollars									

DIVISION 3 - CAST-IN-PLACE CONCRETE

ITEM#	EST. QTY.	UNIT	DESCRIPTION	Wynn Construction		Rudy Construction		Downey Contracting		Greenshade Trees		Weldon Construction	
				UNIT PRICE	ITEM TOTAL	UNIT PRICE	ITEM TOTAL	UNIT PRICE	ITEM TOTAL	UNIT PRICE	ITEM TOTAL	UNIT PRICE	ITEM TOTAL
3.01	742	LF	Concrete Landscape Curb	\$ 36.00	\$ 26,712.00	\$ 45.00	\$ 33,390.00	\$ 20.00	\$ 14,840.00	\$ 28.76	\$ 21,339.92	\$ 12.65	\$ 9,386.30
			Unit Price in Words	Dollars									
3.02	6	TN	Compacted Aggregate Below Landscape Curb	\$ 180.00	\$ 1,080.00	\$ 200.00	\$ 1,200.00	\$ 80.00	\$ 480.00	\$ 102.47	\$ 614.82	\$ 63.25	\$ 379.50
			Unit Price in Words	Dollars									

DIVISION 31 - EARTHWORK

ITEM#	EST. QTY.	UNIT	DESCRIPTION	Wynn Construction		Rudy Construction		Downey Contracting		Greenshade Trees		Weldon Construction	
				UNIT PRICE	ITEM TOTAL	UNIT PRICE	ITEM TOTAL	UNIT PRICE	ITEM TOTAL	UNIT PRICE	ITEM TOTAL	UNIT PRICE	ITEM TOTAL
31.01	31	CY	Earthwork - Grading and Excavation	\$ 350.00	\$ 10,850.00	\$ 80.00	\$ 2,480.00	\$ 150.00	\$ 4,650.00	\$ 61.48	\$ 1,905.88	\$ 74.53	\$ 2,310.43
			Unit Price in Words	Dollars									
31.02	2155	LF	Environmental Protection - Straw Barrier Logs	\$ 5.00	\$ 10,775.00	\$ 4.00	\$ 8,620.00	\$ 3.00	\$ 6,465.00	\$ 3.91	\$ 8,426.05	\$ 4.43	\$ 9,546.65
			Unit Price in Words	Dollars									

Blue highlighted cells denote scrivener's error and differ from contractor's submitted bid sheet.

DIVISION 31 - EARTHWORK CONT.

ITEM#	EST. QTY.	UNIT	DESCRIPTION	UNIT PRICE	ITEM TOTAL	UNIT PRICE	ITEM TOTAL	UNIT PRICE	ITEM TOTAL	UNIT PRICE	ITEM TOTAL	UNIT PRICE	ITEM TOTAL
31.03	2614	LF	Environmental Protection - Tree Protection Fencing	\$ 5.00	\$ 13,070.00	\$ 4.00	\$ 10,456.00	\$ 6.00	\$ 15,684.00	\$ 3.88	\$ 10,142.32	\$ 6.33	\$ 16,546.62
	Unit Price in Words			Dollars									
31.04	1	EA	Environmental Protection - Gravel Wash Down Drive	\$ 4,500.00	\$ 4,500.00	\$ 3,000.00	\$ 3,000.00	\$ 3,500.00	\$ 3,500.00	\$ 3,234.68	\$ 3,234.68	\$ 5,060.00	\$ 5,060.00
	Unit Price in Words			Dollars									
31.05	1721	SY	Strip Site - 6" Depth	\$ 8.00	\$ 13,768.00	\$ 6.00	\$ 10,326.00	\$ 15.00	\$ 25,815.00	\$ 8.51	\$ 14,645.71	\$ 2.93	\$ 5,042.53
	Unit Price in Words			Dollars									
31.06	1721	SY	Final Grading and Screened Topsoil in Planting Beds - 6" Depth	\$ 8.00	\$ 13,768.00	\$ 14.00	\$ 24,094.00	\$ 31.00	\$ 53,351.00	\$ 13.41	\$ 23,078.61	\$ 2.10	\$ 3,614.10
	Unit Price in Words			Dollars									

DIVISION 32 - EXTERIOR IMPROVEMENTS

ITEM#	EST. QTY.	UNIT	DESCRIPTION	UNIT PRICE	ITEM TOTAL	UNIT PRICE	ITEM TOTAL	UNIT PRICE	ITEM TOTAL	UNIT PRICE	ITEM TOTAL	UNIT PRICE	ITEM TOTAL
32.01	8,711	SF	5" Reinforced Concrete Sidewalk (Excavation and Compacted Aggregate)	\$ 12.00	\$ 104,532.00	\$ 13.00	\$ 113,243.00	\$ 10.00	\$ 87,110.00	\$ 10.94	\$ 95,298.34	\$ 12.15	\$ 105,838.65
	Unit Price in Words			Dollars									
32.02	20	SF	Sidewalks - Tactile Warning Dome	\$ 144.00	\$ 2,880.00	\$ 80.00	\$ 1,600.00	\$ 40.00	\$ 800.00	\$ 218.10	\$ 4,362.00	\$ 94.88	\$ 1,897.60
	Unit Price in Words			Dollars									
32.03	1.5	SY	ADA Curb Ramp (Excavation and Compacted Aggregate)	\$ 1,500.00	\$ 2,250.00	\$ 2,500.00	\$ 3,750.00	\$ 300.00	\$ 450.00	\$ 1,894.26	\$ 2,841.39	\$ 332.70	\$ 499.05
	Unit Price in Words			Dollars									
32.04	19.0	TN	Decomposed Granite Trail with Binder	\$ 620.00	\$ 11,780.00	\$ 620.00	\$ 11,780.00	\$ 750.00	\$ 14,250.00	\$ 468.14	\$ 8,894.66	\$ 651.48	\$ 12,378.12
	Unit Price in Words			Dollars									
32.05	1,420	SF	Landscape - Geotextile Fabric	\$ 0.30	\$ 426.00	\$ 0.40	\$ 568.00	\$ 0.50	\$ 710.00	\$ 0.83	\$ 1,178.60	\$ 0.44	\$ 624.80
	Unit Price in Words			Dollars									
32.06	26	TN	Compacted Aggregate Below Decomposed Granite	\$ 120.00	\$ 3,120.00	\$ 170.00	\$ 4,420.00	\$ 225.00	\$ 5,850.00	\$ 74.85	\$ 1,946.10	\$ 126.50	\$ 3,289.00
	Unit Price in Words			Dollars									
32.07	8,174	EA	Landscape - Grass Plugs	\$ 7.00	\$ 57,218.00	\$ 7.85	\$ 64,165.90	\$ 11.00	\$ 89,914.00	\$ 5.55	\$ 45,365.70	\$ 9.49	\$ 77,571.26
	Unit Price in Words			Dollars									
32.08	16	EA	Landscape - Wildflower Seed Mix Bags (15,486 SF Coverage)	\$ 420.00	\$ 6,720.00	\$ 125.00	\$ 2,000.00	\$ 175.00	\$ 2,800.00	\$ 427.88	\$ 6,846.08	\$ 1,068.93	\$ 17,102.88
	Unit Price in Words			Dollars									

Blue highlighted cells denote scrivener's error and differ from contractor's submitted bid sheet.

DIVISION 32 - EXTERIOR IMPROVEMENTS CONT.

ITEM#	EST. QTY.	UNIT	DESCRIPTION	UNIT PRICE	ITEM TOTAL	UNIT PRICE	ITEM TOTAL	UNIT PRICE	ITEM TOTAL	UNIT PRICE	ITEM TOTAL	UNIT PRICE	ITEM TOTAL
32.09	58	CY	Landscape - Cedar Mulch	\$ 132.00	\$ 7,656.00	\$ 205.00	\$ 11,890.00	\$ 175.00	\$ 10,150.00	\$ 841.77	\$ 48,822.66	\$ 139.15	\$ 8,070.70
	Unit Price in Words			Dollars									
32.10	1,644	SY	Landscape - Sod	\$ 5.00	\$ 8,220.00	\$ 4.75	\$ 7,809.00	\$ 5.00	\$ 8,220.00	\$ 4.27	\$ 7,019.88	\$ 4.98	\$ 8,187.12
	Unit Price in Words			Dollars									
32.11	7	EA	Landscape - 2" Caliper Tree	\$ 620.00	\$ 4,340.00	\$ 615.00	\$ 4,305.00	\$ 700.00	\$ 4,900.00	\$ 566.32	\$ 3,964.24	\$ 645.15	\$ 4,516.05
	Unit Price in Words			Dollars									
32.12	1	LS	Landscape - Irrigation System Allowance	\$ 40,000.00	\$ 40,000.00	\$ 36,500.00	\$ 36,500.00	\$ 64,000.00	\$ 64,000.00	\$ 96,104.21	\$ 96,104.21	\$ 59,455.00	\$ 59,455.00
	Unit Price in Words			Dollars									
32.13	4	EA	Furnishing - Retractable Bollard	\$ 1,600.00	\$ 6,400.00	\$ 2,000.00	\$ 8,000.00	\$ 3,100.00	\$ 12,400.00	\$ 1,890.31	\$ 7,561.24	\$ 442.75	\$ 1,771.00
	Unit Price in Words			Dollars									
32.14	5	EA	Furnishing - Bench	\$ 5,300.00	\$ 26,500.00	\$ 3,500.00	\$ 17,500.00	\$ 5,100.00	\$ 25,500.00	\$ 2,892.55	\$ 14,462.75	\$ 4,301.00	\$ 21,505.00
	Unit Price in Words			Dollars									
32.16	2	EA	Furnishing - Trash Receptacle	\$ 2,500.00	\$ 5,000.00	\$ 3,000.00	\$ 6,000.00	\$ 2,400.00	\$ 4,800.00	\$ 2,590.29	\$ 5,180.58	\$ 2,213.75	\$ 4,427.50
	Unit Price in Words			Dollars									
32.17	1	EA	Drainage - Outlet	\$ 360.00	\$ 360.00	\$ 800.00	\$ 800.00	\$ 1,700.00	\$ 1,700.00	\$ 611.45	\$ 611.45	\$ 379.50	\$ 379.50
	Unit Price in Words			Dollars									
32.18	32	LF	Drainage - 4" Perforated Pipe and Connections	\$ 11.00	\$ 352.00	\$ 11.00	\$ 352.00	\$ 20.00	\$ 640.00	\$ 15.22	\$ 487.04	\$ 11.39	\$ 364.48
	Unit Price in Words			Dollars									
32.19	15	LF	Drainage - 4" Tightline Pipe and Connections	\$ 11.00	\$ 165.00	\$ 11.00	\$ 165.00	\$ 20.00	\$ 300.00	\$ 11.83	\$ 177.45	\$ 11.39	\$ 170.85
	Unit Price in Words			Dollars									
32.20	0.68	TN	Drainage - #57 Aggregate	\$ 120.00	\$ 81.60	\$ 120.00	\$ 81.60	\$ 200.00	\$ 136.00	\$ 95.97	\$ 65.26	\$ 126.50	\$ 86.02
	Unit Price in Words			Dollars									
32.21	25	TONS	Rain Garden Stone - Washita 3-6"+	\$ 550.00	\$ 13,750.00	\$ 550.00	\$ 13,750.00	\$ 640.00	\$ 16,000.00	\$ 189.58	\$ 4,739.50	\$ 600.88	\$ 15,022.00
	Unit Price in Words			Dollars									
32.22	4	EA	Railing	\$ 2,200.00	\$ 8,800.00	\$ 1,500.00	\$ 6,000.00	\$ 1,700.00	\$ 6,800.00	\$ 1,622.59	\$ 6,490.36	\$ 1,012.00	\$ 4,048.00
	Unit Price in Words			Dollars									

Blue highlighted cells denote scrivener's error and differ from contractor's submitted bid sheet.

DIVISION 32 - EXTERIOR IMPROVEMENTS CONT.

ITEM#	EST. QTY.	UNIT	DESCRIPTION	UNIT PRICE	ITEM TOTAL	UNIT PRICE	ITEM TOTAL	UNIT PRICE	ITEM TOTAL	UNIT PRICE	ITEM TOTAL	UNIT PRICE	ITEM TOTAL
32.23	36	LF	Pavement Markings - 24" Thermoplastic	\$ 162.00	\$ 5,832.00	\$ 50.00	\$ 1,800.00	\$ 20.00	\$ 720.00	\$ 50.84	\$ 1,830.24	\$ 18.98	\$ 683.28
	Unit Price in Words			Dollars									
32.24	2	EA	Concrete Underdrain - Match Existing	\$ 3,000.00	\$ 6,000.00	\$ 2,500.00	\$ 5,000.00	\$ 4,000.00	\$ 8,000.00	\$ 685.47	\$ 1,370.94	\$ 1,391.50	\$ 2,783.00
	Unit Price in Words			Dollars									
BASE BID TOTAL				\$	\$ 568,935.60	\$ 496,740.50	\$ 696,665.00	\$ 488,705.54	\$ 503,175.91				
Base Bid Total in Words				Dollars									

ADD ALTERNATE 1

ADD ALTERNATE 1

ITEM#	EST. QTY.	UNIT	DESCRIPTION	UNIT PRICE	ITEM TOTAL	UNIT PRICE	ITEM TOTAL	UNIT PRICE	ITEM TOTAL	UNIT PRICE	ITEM TOTAL	UNIT PRICE	ITEM TOTAL
A1.01	211	LF	Concrete Landscape Curb	\$ 36.00	\$ 7,596.00	\$ 45.00	\$ 9,495.00	\$ 20.00	\$ 4,220.00	\$ 28.25	\$ 5,960.75	\$ 12.65	\$ 2,669.15
	Unit Price in Words			Dollars									
A1.02	1.7	TN	Compacted Aggregate Below Landscape Curb	\$ 540.00	\$ 918.00	\$ 300.00	\$ 510.00	\$ 75.00	\$ 127.50	\$ 105.11	\$ 178.69	\$ 63.25	\$ 107.53
	Unit Price in Words			Dollars									
A1.03	1	LS	Earthwork - Grading and Excavation	\$ 6,000.00	\$ 6,000.00	\$ 2,000.00	\$ 2,000.00	\$ 11,000.00	\$ 11,000.00	\$ 3,495.97	\$ 3,495.97	\$ 4,427.50	\$ 4,427.50
	Unit Price in Words			Dollars									
A1.04	176	LF	Environmental Protection - Straw Barrier Logs	\$ 5.00	\$ 880.00	\$ 4.00	\$ 704.00	\$ 3.00	\$ 528.00	\$ 4.41	\$ 776.16	\$ 5.06	\$ 890.56
	Unit Price in Words			Dollars									
A1.05	291	LF	Environmental Protection - Tree Protection Fencing	\$ 6.00	\$ 1,746.00	\$ 4.00	\$ 1,164.00	\$ 6.00	\$ 1,746.00	\$ 2.83	\$ 823.53	\$ 22.61	\$ 6,579.51
	Unit Price in Words			Dollars									
A1.06	25	TN	Decomposed Granite Trail with Binder	\$ 620.00	\$ 15,500.00	\$ 620.00	\$ 15,500.00	\$ 750.00	\$ 18,750.00	\$ 348.24	\$ 8,706.00	\$ 651.48	\$ 16,287.00
	Unit Price in Words			Dollars									
A1.07	2,442	SF	Landscape - Geotextile Fabric	\$ 0.30	\$ 732.60	\$ 0.30	\$ 732.60	\$ 0.50	\$ 1,221.00	\$ 0.68	\$ 1,660.56	\$ 0.32	\$ 781.44
	Unit Price in Words			Dollars									
A1.08	55	TN	Compacted Aggregate Below Decomposed Granite	\$ 120.00	\$ 6,600.00	\$ 120.00	\$ 6,600.00	\$ 175.00	\$ 9,625.00	\$ 95.97	\$ 5,278.35	\$ 126.50	\$ 6,957.50
	Unit Price in Words			Dollars									
A1.09	6	EA	Landscape - 2" Caliper Tree	\$ 620.00	\$ 3,720.00	\$ 615.00	\$ 3,690.00	\$ 700.00	\$ 4,200.00	\$ 745.62	\$ 4,473.72	\$ 645.15	\$ 3,870.90
	Unit Price in Words			Dollars									

Blue highlighted cells denote scrivener's error and differ from contractor's submitted bid sheet.

ADD ALTERNATE 1 CONT.

ITEM#	EST. QTY.	UNIT	DESCRIPTION	UNIT PRICE	ITEM TOTAL	UNIT PRICE	ITEM TOTAL	UNIT PRICE	ITEM TOTAL	UNIT PRICE	ITEM TOTAL	UNIT PRICE	ITEM TOTAL
A1.10	1	LS	Landscape - Irrigation System Allowance	\$ 5,500.00	\$ 5,500.00	\$ 5,400.00	\$ 5,400.00	\$ 7,500.00	\$ 7,500.00	\$ 4,111.88	\$ 4,111.88	\$ 56.93	\$ 56.93
Unit Price in Words				Dollars									
A1.11	7	EA	Furnishing - Bench	\$ 5,250.00	\$ 36,750.00	\$ 3,500.00	\$ 24,500.00	\$ 5,000.00	\$ 35,000.00	\$ 2,951.01	\$ 20,657.07	\$ 4,301.00	\$ 30,107.00
Unit Price in Words				Dollars									
A1.12	2	EA	Furnishing - Games Table	\$ 5,000.00	\$ 10,000.00	\$ 5,500.00	\$ 11,000.00	\$ 4,000.00	\$ 8,000.00	\$ 4,784.39	\$ 9,568.78	\$ 1,075.25	\$ 2,150.50
Unit Price in Words				Dollars									
A1.13	3	EA	Drainage - Outlet	\$ 360.00	\$ 1,080.00	\$ 800.00	\$ 2,400.00	\$ 1,700.00	\$ 5,100.00	\$ 572.22	\$ 1,716.66	\$ 379.50	\$ 1,138.50
Unit Price in Words				Dollars									
A1.14	123	LF	Drainage - 4" Perforated Pipe and Connections	\$ 11.00	\$ 1,353.00	\$ 11.00	\$ 1,353.00	\$ 15.00	\$ 1,845.00	\$ 20.27	\$ 2,493.21	\$ 11.39	\$ 1,400.97
Unit Price in Words				Dollars									
A1.15	30	LF	Drainage - 4" Tightline Pipe and Connections	\$ 11.00	\$ 330.00	\$ 11.00	\$ 330.00	\$ 15.00	\$ 450.00	\$ 20.64	\$ 619.20	\$ 11.39	\$ 341.70
Unit Price in Words				Dollars									
A1.16	0.35	TN	Drainage - #57 Aggregate	\$ 120.00	\$ 42.00	\$ 120.00	\$ 42.00	\$ 175.00	\$ 61.25	\$ 105.11	\$ 36.79	\$ 126.50	\$ 44.28
Unit Price in Words				Dollars									
A1.17	23	TONS	8" Rip Rap	\$ 150.00	\$ 3,450.00	\$ 120.00	\$ 2,760.00	\$ 120.00	\$ 2,760.00	\$ 128.13	\$ 2,946.99	\$ 398.48	\$ 9,165.04
Unit Price in Words				Dollars									

ADD ALT 1 BID TOTAL	\$	\$ 102,197.60	\$ 88,180.60	\$ 112,133.75	\$ 73,504.31	\$ 86,976.00	
Add Alt 1 Bid Total in Words		Dollars					

TOTAL AMOUNT BID*	\$	\$ 671,133.20	\$ 584,921.10	\$ 808,798.75	\$ 562,209.85	\$ 590,151.91	
Total Amount Bid in Words		Dollars					

* Base Bid + Add Alternate 1 Bid

Blue highlighted cells denote scrivener's error and differ from contractor's submitted bid sheet.

CONTRACT AGREEMENT

THIS CONTRACT AND AGREEMENT, made and entered into this 18th day of Dec, 2023 by and between the City of Moore, Moore, Oklahoma, party of the first part, hereinafter termed "Owner", and Greenshade Tree LLC., party of the second part, hereinafter termed "Contractor".

WITNESSETH:

WHEREAS, the Owner has caused to be prepared, in accordance with law, certain specifications, plans, and other bidding documents for the work hereinafter described and has approved and adopted all of said bidding documents and has received sealed proposals for furnishing materials, labor, and equipment for either of the indicated works.

This project consists of furnishing all required materials, supplies, equipment, tools, and plans to perform all necessary labor for the construction of and installation of:

**Installation of Veterans Memorial Park Trail Enhancements and other amenities noted in
Bid 2024-006:**

Veterans Memorial Park 1900 SE 4th Street, Moore OK 73160

The work shall be done in accordance with the 2021 International Building Code (IBC) and specifications on file in the City Clerk's Office as outlined and set out in the bidding documents and in accordance with the terms, specifications, plans, and provisions of said Contract; and,

WHEREAS, Contractor, in response to request for bids #2024-006, has submitted to the City of Moore, OK, in the manner and at the time specified, a sealed proposal in accordance with the terms of this Contract; and,

WHEREAS, City of Moore, in the manner provided by law, has publicly opened, examined, and canvassed the proposals submitted and has determined and declared the above-named Contractor to be the lowest responsible bidder on the above described project, and has duly awarded this Contract to said Contractor, for the sum named in the proposal to-wit:

Five Hundred Sixty-Two Thousand Two Hundred and Nine Dollars and Eighty-Five Cents
\$562,209.85

NOW, THEREFORE, for and in consideration of the mutual agreements and covenants herein contained, the parties to this Contract have agreed, and hereby agree, as follows:

(1) That the Contractor hereby agrees to furnish all tools, equipment, materials, and labor, and to build and complete the above described project in accordance with the specifications therefore on file in the office of the City Clerk of Moore, Oklahoma.

(2) That the Owner shall pay the Contractor for the work performed, as follows:

- a. Payment for unit price items shall be at the unit price bid for actual construction quantities.
- b. Construction items specified, but not included as bid items, shall be considered incidental and shall not be paid for directly but shall be included in the bid price for any or all of the pay quantities.
- c. At the end of each month the Contractor may make written estimates of the materials in place and accepted, and the amount of work performed in accordance with the contract during the current period of time between estimates and the value thereof computed at the contract unit prices. Payment to the Contractor shall be in the amount of the estimate minus the retainage as permitted by law.
- d. Should any defective work or materials be discovered or should a reasonable doubt arise as to the quality of any work completed, there will be deducted from the next estimate an amount equal to the value of the defective or questionable work and shall not be paid until the defects are remedied.
- e. And that the Contractor's bid is hereby made a part of this Agreement.

(3) City of Moore, OK, reserves the right to add to or subtract from the estimated quantities or amount of work to be performed. The work to be performed or deducted shall be at the unit price bid.

(4) That the Contractor will not undertake to furnish any materials or to perform any work not specifically authorized under the terms of this Agreement unless additional materials or work are authorized by written work directive change; and that in the event any additions are provided by the Contractor without such authorization, the Contractor shall not be entitled to any compensation therefor whatsoever.

(5) That if any additional work is performed or additional materials provided by the Contractor upon authorization by the Owner, the Contractor shall be compensated therefore at the unit bid price and as agreed to by both parties in the execution of the Change Order.

(6) That the Contractor shall perform the work and provide the materials strictly in accordance with the specifications as to quality and kind and all work and materials shall be subject to rejection by the Owner through its authorized representatives for failure to meet such requirements, and in the event of such rejection, the Contractor shall replace the work and materials without compensation therefor by the Owner.

(7) The Contractor shall complete the work in accordance with the terms of this Agreement within a period of time not to exceed **180 calendar days** following the issuance by the City of a Work Order authorizing the Contractor to commence work on the project. The Contractor further agrees to pay as liquidated damages, the sum of **Eight Hundred Dollars and 00/100 (\$800.00)** for each consecutive calendar day thereafter as provided in the contract and general conditions.

(8) On completion of the work, but prior to the acceptance thereof by the City of Moore, OK, it shall be the duty of the Parks and Recreation Director or other appropriate person to determine that said

work has been completely and fully performed in accordance with said Contract Documents; and upon making such determination said official shall make his final certificate to the City of Moore, OK.

IN WITNESS WHEREOF, the parties hereto have caused this instrument to be executed, in four duplicate originals, the day and year first above written.

"OWNER"

City of Moore, OK

By: _____

ATTEST

City Clerk

APPROVED as to form and legality this _____ day of _____, 20____.

"CONTRACTOR"

8 day of December, 2023

If an Individual: (signature)

Doing business as: Greenshade Trees, LLC

If a Partnership: (signature)

By (Printed Name and Title):

Justin Luge

Names of Other partners: _____

City of Moore
Request for Proposal #2024-007
Youth Baseball Leagues/Tournaments Provider

I. Introduction

The City of Moore (City) has established criteria for a Youth Baseball Leagues/Tournaments Provider Request for Proposal (RFP). The City is seeking proposals from all qualified organizations to provide baseball leagues & tournaments during 2024 and to work year to year to ensure the best possible environment for the Citizens of Moore.

Examples of possible leagues and/or tournaments offered could be:

1. Spring Youth Baseball League offered between the months of March and June.
2. Fall Youth Baseball League between the months of September to November.
3. Youth Baseball Tournaments offered from March to November.
4. Adult Baseball Leagues.
5. Courage or Adaptive Leagues.

City Philosophy

The City believes in the overall benefits of participation in organized youth sports leagues and programs. Participation in sports plays a valuable role in the development of the youth of Moore and surrounding areas. Participation in youth recreational leagues and tournaments has proven to build self-esteem, promote teamwork, develop the body as well as the mind, and is an integral part of the maturation process, all of which contribute to the overall quality of life in Moore and surrounding communities. The City will strive to assist youth sports leagues/tournaments providers in offering quality organized youth sports programs, facilities, and services while maintaining a safe, wholesome environment for children.

II. Youth Sports League Provider Requirements

Each youth sports league/tournament provider must meet certain standardized minimum requirements in order to provide youth sports leagues/tournaments to the community. These requirements include:

1. Each provider must be chartered with the State of Oklahoma as a non-profit organization.
2. Each provider should be approved by the Internal Revenue Service (IRS) as a 501(c)3 non-profit entity. If the provider does not have their 501(c)3 tax-exempt status, the provider must show proof that an application has been filed with the IRS. A provider shall not use the 501(c)3 status of another entity.
3. Each provider must have published bylaws that provide for the election of board members and officers, as well as overall governance of the organization/association.
4. Recreation should be the primary focus of all youth sports league providers. It is considered beneficial to afford some higher level of play within each youth/sports league.
5. Each provider shall ensure adult supervision is present in an official capacity for every youth league practice, official league game, and tournament game held on the city property.

6. Each provider shall encourage staff, coaches, and parents to conduct themselves as positive role models exemplifying proper sportsmanship, cooperation and appropriate behavior. The youth sports league provider will validate the quality of adult leadership by requiring nationwide criminal background checks of all head coaches, board members, and any other person acting in an official capacity with the youth sports league provider directly overseeing children. Background checks are valid for a one-year period. The background check must be approved by the Parks and Recreation Director or his/her designee.
7. The youth sports league/tournament provider will manage the concession stand.
8. The youth sports league/tournament provider must operate year-round. Organizations that are awarded the use of the Buck Thomas Park Baseball Complex may NOT subcontract to other organizations to run practices or leagues/tournaments without approval from the City of Moore.
9. Each provider shall ensure fiscal responsibility by establishing and operating according to generally accepted accounting principles and practices. All income derived from the use of City owned or leased facilities shall be used solely to defray costs and expenses of legitimate activities.

III. Submittals

Each proposal shall include, but is not limited to, the following information. Please fill out or use the attached Questionnaire/Checklist Form.

Section 1 – Organization / Contact Information

The organization interested in operating the Youth Baseball Association should provide the name of the organization, names of individuals associated with the proposal, their title(s), mailing address, phone number, and email address.

Section 2 – Organizational Structure

The organization should provide organizational structure and league and/or tournament overview. This includes information such as:

- Organizational Leadership – Board/Organizational chart
- League Format and/or Tournament format
 - For Leagues – provide detailed plans for practices, game days. (Example – number of games and practices each team will have per season)
 - For Tournaments – provide plans for number of tournaments and how many games you are guaranteeing at each of them
 - Registration Process
 - Provide proposed registration dates and deadlines for each season/tournament
 - Provide details of how the organization will handle the registration of participants and teams. (Example – online, walk-in, mail in, late registration, method of payment, etc.)
 - Proposed start date and end date of each league/tournament
 - Grievance process

- Staffing - League administrators, Tournament Director, Umpire In Charge, Field/Gate Monitors. These shall be submitted to the Parks and Recreation Director before they are allowed to be on the fields or in the concession stands.
- Coaches - Background check confirmation list, training, certifications, etc. These shall be submitted to the Parks and Recreation Director before they are allowed to be on the fields.
 - The City provides a website link for background checks to be run based on City approved criteria. If you choose to use another party for background checks, the criteria must be approved by the Parks and Recreation Director.
- Provide rules governing league and tournament play
- Provide bylaws for organization
- Mission Statement
- 2 years of Annual Financial Reports (If any)
- Any other information that would be helpful in determining the qualifications, organizational skills, and resources of the applicants.

Lease Fee:

- The organization will be required to pay the City an annual lease fee of \$6,800.00.

Concession:

- Provide all equipment necessary to operate a concession stand

Section 3 – Program Fees

Program Fees

- Provide the city with an estimated cost per individual, per season for league/tournament participants
- Include the estimated number of individual participants per season/tournament.

Section 4 – Operation & Maintenance

Maintenance Requirements:

- The organization will be required to pay for expenses related to:
 - Field maintenance, including but not limited to field dirt, safe coat, conditioner, chalk, mare mound or any other field needs as required.
 - Restroom cleaning and supplies.
 - Trash and debris collection and removal throughout the complex and supplies needed.

Concession:

- Provide all equipment and supplies necessary to operate a concession stand

Section 5 – Experience

Provide any prior experience in operating and/or managing a youth baseball association or involvement in other youth sports associations including any references.

IV. Insurance Requirements

Selected organization(s) will be required to obtain public liability insurance of the types and the amounts set forth below from an underwriter licensed to do business in the State of Oklahoma.

The insurance shall be the following types in the amounts not less than indicated:

1. Comprehensive General (Public) Liability or its equivalent, including \$500,000 each person, \$1,000,000 each occurrence, and property damage \$250,000 per occurrence or \$1,000,000 combined single limit for bodily injury and property damage.
2. On all insurance required, selected organization shall be required to name the City of Moore Public Works Authority as additional insured.

V. Contract Term

The organization selected by the City to provide the services of youth baseball leagues/tournaments provider will be required to enter into an annual lease agreement with the City prior to offering their services. The term of the agreement for the organization selected to be the youth/sports provider for baseball leagues/tournaments shall be for a period of one year commencing on a date to be determined by the City. The mobile (not attached to the building or structures) equipment that is in all of the concession or surrounding buildings belongs to the association and the provider will be required to maintain all equipment. If there are repairs or if equipment replacement is needed, the provider will be required to repair or purchase the replacement equipment.

The agreements first term will be from commencement to November 1, 2024. Each term thereafter will be for one year and may be terminated with or without cause by either party by giving thirty (30) days written notice to the other party. If there is possible reconciliation to any issues that may arise, every effort shall be given to resolve said issues. The City will work to maintain a good working relationship and will attempt to work out any issues for the benefit of all parties and the league participants.

VI. Evaluation Criteria

The City of Moore Parks Board will judge the merit of proposals received in accordance with the requirements defined herein. Failure of applicant to provide in their proposal any information requested in this RFP may result in disqualification of the proposal. The sole objective of the City of Moore Parks Board will be to select and recommend the youth baseball leagues/tournaments provider that presents the best overall program to the City of Moore.

An annual user agreement for youth baseball leagues/tournaments provider will be awarded (with City Council approval) based on the recommendation of the City of Moore Parks Board.

VII. Best and Final Offer

The City reserves the right to request a best and final offer from any or all organizations. The City reserves the right to reject any or all proposals, with or without cause, re-issue the RFP, or proceed in any manner determined to be in the best interest of the City.

City of Moore
Youth Baseball Leagues/Tournaments Provider
Request for Proposal #2024-007

Proposal Title: RFP#2024-007 “Youth Baseball Leagues/Tournaments Provider”

Proposals Due: 01/09/2024 @ 2:00pm (local time)

Proposal Opening: 01/09/2024@2:10pm (local time) @ Moore City Hall

Proposals for the services specified will be received by the City of Moore until the date and time as indicated above.

Please submit one (1) original proposal and three (3) copies of the proposal in hard copy form only.

Proposals should be submitted in person to:

Barbara Furgiani
Purchasing at City Hall
301 N. Broadway
Moore, Ok 73160
(405) 793-5000

Deadline for proposals submission is 01/09/2024 @ 2:00pm (local time)

No Digital submission will be accepted.

Proposal Opening: 01/09/2024@2:10pm (local time) @ City Hall

Please label - Proposal – RFP#2024-007 “Youth Baseball Leagues/Tournaments Provider”.

Late submissions will not be considered. Proposals received after the deadline will not be considered for the award of the agreement and will be returned unopened. Proposals must be submitted with the label as described above, and the respondent’s name and address clearly indicated on the front of the envelope. Additional instructions for preparing a proposal are provided within. The City of Moore appreciates your time and effort in preparing a proposal.

Questions about the RFP:

Whitney Wathen, Parks & Recreation Assistant Director; wwathen@cityofmoore.com ; 405-793-5090

or

Sue Wood, Parks & Recreation Director; swood@cityofmoore.com ; 405-793-5090

or

Barbara Furgiani, Purchasing Agent; Bfurgiani@cityofmoore.com ; 405-793-5000

RFP#2024-007 Questionnaire / Checklist Form

It is REQUIRED to fill in all blanks and provide all requested documentation.

Section 1 - Organization / Contact Information

Name of Organization: _____

Name of Person Submitting the Proposal:

Name: _____

Phone Number: _____

Mailing Address: _____

Email: _____

Section 2 - Organizational Structure

1. Submit a copy of the Provider’s Organizational Chart or Structure. If one has not been created yet, show the proposed structure of your organization.

League Format

2. Age Ranges offered: _____

3. Number of games planned: _____

4. What days do you plan to schedule games: _____

5. Number of practices planned per week: _____

6. Proposed Start and End of each season: _____

Tournament Format

7. How many tournaments during the year: _____

Registration Process

8. Proposed registration dates and deadlines for each season: _____

9. Describe how registration will be conducted (Example - online, walk-in, mail in, late registration, method of payment etc.):

10. Please describe or provide a copy of your Grievance Procedure Policy: _____

11. Please provide a copy of the rules you will be following for league / tournament play.

12. Please provide bylaws for your organization.

13. Please provide your mission statement.

14. Please provide a copy of your organization's financial statements.

15. Please provide any other information that would be helpful in determining the qualifications, organizational skills, and resources of the applicants.

Section 3 - Program Fees

16. What is the estimated cost per individual, per season (If there is a different cost for different age groups, please specify):

17. What is the estimated number of individual participants per season or tournament:

18. Will you agree to the organization being required to pay for expenses related to: Concession equipment and supplies, field maintenance, including but not limited to field dirt, safe coat, conditioner, chalk, mare mound or any other field needs as required, restroom cleaning and supplies, trash and debris collection and removal throughout the complex?

Section 4 – Operation & Maintenance

19. Do you plan to make any improvements to the fields or facilities? If so, what improvements would you propose doing?

20. Will you operate or contract out the Concession Stand operation? _____

Section 5 - Experience

21. Please provide any prior experience in operating and/or managing a youth baseball / softball association or involvement in other youth sports associations including any references.

22. Please provide a copy of the State of Oklahoma issued Charter for your organization that shows you are doing business in the State of Oklahoma as a nonprofit organization.

23. Please provide a copy of a letter from the IRS showing that you have been approved by them as tax-exempt organization. If you do not have your 501(c)3 status at this time, please provide proof that you have submitted that application to the IRS for their consideration.

BUDGET AMENDMENT FORM

Fund: 05, 06, 08
 Amendment #: 24-05
 Fiscal Year: 2023-2024

Account #	Account Name	Estimated Revenue		Appropriations		
		Increase	Decrease	Increase	Decrease	
05010350-53022	Building			905,310.00		1
05040100-49300	Budgeted Fund Balance	905,310.00				
06020540-52006	Training			6,217.97		2
06010090-49300	Budgeted Fund Balance	6,217.97				
06050740-52170	Special Projects			1,000.00		3
06050060-46690	Donations	1,000.00				
08052070-55040	Buck Thomas Softball Imp.			1,400.00		
08010090-49300	Budgeted Fund Balance	1,400.00				
08022310-55310	Police Donations Expense			26,926.10		4
08020080-48535	Police Donations Revenue	26,926.10				
08022340-55433	JAG Grant Expense			3,195.00		
08020030-43277	JAG Grant Revenue	3,195.00				
TOTALS		<u>\$ 944,049.07</u>	<u>\$ -</u>	<u>\$ 944,049.07</u>	<u>\$ -</u>	

EXPLANATION:

- Budget purchase of 2001 N. Moore Ave and related costs. Council approved purchase on September 18, 2023.
- Carryover prior year budgeted equipment requirement per union contract.
- Budget Parks donation received during FY2024 for bench and increase FY2024 Softball Improvements budget to utilize prior year collections for light repairs.
- Budget additional grants and donations received by Police Department during FY2024.

Signature & Date Approved by City Manager: 12-6-23 [Signature]
 Date Signature

Date Approved by City Council: _____
 Date

**STANDARD
FORM OF AGREEMENT
BETWEEN CITY OF MOORE
AND ENGINEER
FOR
PROFESSIONAL SERVICES**



Issued By
CITY MANAGEMENT DEPARTMENT
In conjunction with the
CITY'S LEGAL DEPARTMENT

CITY HALL, 301 N. Broadway
Moore, Oklahoma

AGREEMENT
BETWEEN
CITY OF MOORE AND ENGINEER
FOR
PROFESSIONAL DESIGN SERVICES
FOR

**N.W. 27th STREET RECONSTRUCTION PROJECT FROM
HILLCREST AVENUE EXTENDING EAST TO THE I-35
SERVICE ROAD**

CITY OF MOORE
CLEVELAND COUNTY, OKLAHOMA

DATE: December 18, 2023

PREPARED BY:
City of Moore
City Management Department

Table of Contents

- 1. SECTION 1 - BASIC SERVICES OF ENGINEER4
 - 1.1. General.....4
 - 1.2. Preliminary Design Phase11
 - 1.3. Final Design Phase.....11
 - 1.4. Advertising and Bidding Phase.....12
 - 1.5. Construction Phase.....12
- 2. SECTION 2 - OWNER`S RESPONSIBILITIES13
- 3. SECTION 3 - PERIOD OF SERVICES15
- 4. SECTION 4 - PAYMENTS TO ENGINEER16
 - 4.1. Methods of Payment for Services of Engineer.16
 - 4.2. Times of Payment.16
- EXHIBIT “A” SCOPE OF SERVICES.....20
- EXHIBIT “B” BASIS OF COMPENSATION.....26

**AGREEMENT
BETWEEN
CITY OF MOORE AND ENGINEER
FOR
PROFESSIONAL SERVICES**

THIS IS AN AGREEMENT made as of the 18th day of December in the year 2023 by and between the City of Moore, A Municipal Corporation in the State of Oklahoma (hereinafter called OWNER), and TEIM Design, PLLC (hereinafter called ENGINEER). OWNER intends to employ a Professional Engineer to provide engineering services and prepare contract documents for the N.W. 27th Street Reconstruction Project from Hillcrest Avenue extending east to the I-35 Service Road, hereinafter referred to as the PROJECT.

The OWNER and ENGINEER in consideration of their mutual covenants herein agree in respect of the performance of professional engineering services by ENGINEER and the payment for those services by OWNER, as set forth below.

ENGINEER shall serve as OWNER's professional engineering representative in those phases of the PROJECT to which this agreement applies and will give consideration and advice to OWNER during the performance of their services.

1. SECTION 1 - BASIC SERVICES OF ENGINEER

1.1. General

- 1.1.1. ENGINEER shall perform professional services as hereinafter stated which include normal civil, surveying, and geotechnical activities as required.
- 1.1.2. Laws, Licenses and Permits. The ENGINEER shall comply with all Federal, State, and local laws, regulations, and ordinances applicable to the contract.
- 1.1.3. Worker's Compensation Law. The ENGINEER shall comply with the Oklahoma Worker's Compensation Law and file a copy of their Worker's

Compensation Insurance Policy, or, if a self-insurer, a copy of the Industrial Commission's Order of Authorization with the OWNER.

- 1.1.4. ENGINEER's Liability. The ENGINEER shall assume responsibility for and save the OWNER harmless from claims for injury to, or death of persons, or damage to property arising from the ENGINEER's negligent acts, errors, or omissions, or those of their agents or employees, arising out of performance of the work.
- 1.1.5. Non-collusion. The ENGINEER warrants that they have not employed or retained any company or person, other than a bona fide employee working solely for the ENGINEER to solicit or secure this contract, and that they have not paid or agreed to pay any company, political group, or person, other than a bona fide employee working solely for the ENGINEER, any fee, commission, percentage, brokerage fee, gifts, or any other consideration, contingent upon or resulting from the award of this contract. For breach of violation of this warranty, the OWNER shall have the right to annul this contract without liability, or at its discretion to deduct from the contract price or consideration, or otherwise recover the full amount of such price or consideration, or otherwise recover the full amount of such fee, commission, percentage, brokerage fee, gift, or contingent fee.
- 1.1.6. Services Furnished, Performed, and Submitted. The ENGINEER shall furnish all engineering services, labor and equipment as may be required in the performance of the contract, except as otherwise provided herein, and all work performed and submitted under the contract shall be done in a manner acceptable to the OWNER, and the ENGINEER shall sign the plans submitted to the OWNER and affix Oklahoma seal thereto as proof that they are a Registered Professional Engineer in the State of Oklahoma.
- 1.1.7. Coordination of Work. The ENGINEER will coordinate their engineering work with other engineers performing engineering work immediately adjoining the PROJECT, as required. The ENGINEER shall furnish and share survey and plan data in such a manner as will facilitate and expedite the completion of contracts of the PROJECT and adjacent engineering work.
- 1.1.8. Maintaining All Records. The ENGINEER shall maintain all books, documents, papers, accounting records, and other evidence pertaining to cost incurred in the performance of this contract and to make such materials available to their respective offices at all reasonable times during the contract period and for five (5) years from the date of final payment under the contract, for inspection by authorized representatives of the OWNER. Copies thereof shall be furnished if requested and the OWNER shall pay a reasonable cost of reproduction.
- 1.1.9. Responsibility for Accuracy. The ENGINEER will be held responsible for accuracy of engineering details and quantities of work to be performed.

Plans received for review by the OWNER shall be accompanied by a written statement that a prior detailed check has been made. Frequent occurrence of irregularities in engineering details or quantities will be basis for withholding future engineering contracts from said ENGINEER or termination of this agreement upon failure to remedy the problem within a reasonable period of time. The ENGINEER shall furnish design data with computations for all improvements involved in this contract. The ENGINEER will be held responsible for any mistakes or omissions in the work of the ENGINEER, which appear during the final review by the OWNER or during construction and will be required to do any work necessary to correct the mistakes or omissions in their work, without additional compensation.

- 1.1.10. Major Revisions. For any major revisions ordered in writing by the OWNER in the PROJECT after the final survey has been completed, a supplemental agreement for additional payment shall be entered into between the parties hereto. For any major revision in the character or scope of the work in design ordered in writing by the OWNER after performance of a substantial amount of work on the plans, a Supplemental Agreement will be negotiated on the basis of all costs related to the salaries of employees for the time directly chargeable to the agreement, the salaries of principals for the time they are productively engaged in work necessary to fulfill the term of the agreement, direct non-salary cost incurred in fulfilling the terms of the agreement and the ENGINEER's overhead or indirect costs to the extent they are properly allowable to the agreement plus a lump sum for profit.
- 1.1.11. Right to Terminate. The OWNER reserves the right to terminate the contract at any time, and if the PROJECT should be abandoned, or the processing of the PROJECT be indefinitely postponed, or if the contract is terminated for any other reasons, the ENGINEER shall be paid the reasonable value by the OWNER for the data delivered or is ready for delivery upon receipt thereof based upon availability of funds for this work, and such determination by the OWNER shall be conclusive and binding. Prior to the award of the contract to the ENGINEER, the OWNER shall confirm to the ENGINEER and provide satisfactory proof that funds for the amount of the contract have been authorized, allocated, and reserved for payment of the ENGINEER's fee.
- 1.1.12. Right to Delete. The OWNER reserves the right to delete any portion of the contract at any time, and if such is done the total engineering fee shall be reduced in the same ratio as the estimated cost of the work deleted compares to the estimated cost of the work as originally planned, or when appropriate, the engineering fee shall be recomputed for the reduced scope of work in the same manner used for determining the original contract fee, provided that if work has already been accomplished on that portion of the contract which is to be deleted, the ENGINEER shall be paid for the deleted

portion on the basis of the estimated percentage of completion of such portion.

- 1.1.13. Non-Discrimination. The ENGINEER will comply with all the requirements pertaining to the Section 3 Clause of the 1968 Housing and Urban Development Act (Affirmative Action Plan).
- 1.1.14. Assignments and Subleases. ENGINEER shall not assign, sublease, subcontract, transfer, or convey any interest in this agreement without the express and prior written consent of the OWNER. The ENGINEER's interest hereunder shall not be assignable in bankruptcy or by operation of law. In the event a transfer is approved by OWNER, any document by which an interest is granted shall indicate that the person acquiring the interest is subject to the terms of this agreement. The OWNER may prescribe any conditions to such an assignment or transfer.
- 1.1.15. Waiver. No waiver of default by OWNER or ENGINEER of any terms, covenants, or conditions herein to be performed, kept, or observed by the ENGINEER or OWNER shall be construed to be or act as a waiver of any subsequent default of any terms, covenants, or conditions herein contained.
- 1.1.16. Merger. It is mutually understood and agreed by the parties hereto that this agreement contains all the covenants, agreements, stipulations, and provisions agreed upon by said parties, and no agent or employee of either party to this agreement has any authority to alter or change the terms hereof, except as provided herein, and neither party is or shall be bound by any statement or representation not in conformity herewith.

If in the event that any portion or portions of this agreement are adjudged unlawful by a court of competent jurisdiction, the judgment of such court shall not affect the validity of the remaining portions hereof, which shall be and remain in full force and effect during the term of this agreement.

- 1.1.17. Enforceability; Choice of Law; Choice of Forum. Litigation arising out of or connected with this agreement may be instituted and maintained in the courts of the state of Oklahoma only, and the parties consent to jurisdiction over their person and over the subject matter of any such litigation.
- 1.1.18. Key Personnel. The ENGINEER shall have designated certain key personnel to be assigned specifically to the performance of this work (such as project manager, lead designer, operations specialist, etc.). At the time of agreement ratification, the OWNER shall have the right to specify those project key personnel for whom the ENGINEER shall not be allowed to substitute other personnel without prior written permission of the OWNER.
- 1.1.19. Detailed Scope of Services. A detailed scope of services is attached as Exhibit "A", which is hereby incorporated into this contract.

1.1.20. Insurance. The ENGINEER shall procure and maintain during the life of this agreement insurance of the types of minimum amounts as follows:

Worker's Compensation in full compliance with statutory requirements of Federal and State of Oklahoma law and Employer's Liability coverage in the amount of \$500,000.

Commercial General Liability and Bodily Injury:

Bodily Injury	\$ <u>125,000</u> each occurrence
Property Damage	\$ <u>100,000</u> each occurrence
Combined Single Limit	<u>\$1,000,000</u> aggregate

Comprehensive Automobile:

Liability, Bodily Injury	\$ <u>125,000</u> each occurrence
Property Damage	\$ <u>100,000</u> each occurrence
Combined Single Limit	<u>\$1,000,000</u> aggregate

<u>Professional Liability:</u>	\$ <u>500,000</u> per claim
<u>(Errors and Omissions):</u>	<u>\$1,000,000</u> aggregate

Certificate evidencing such insurance shall be furnished to the OWNER and shall contain the following statement: "The insurance evidenced by this certificate will not be canceled or altered except after ten (10) calendar days from receipt by the OWNER of written notice thereof." Should the insurance outlined above be canceled for any reason, and the ENGINEER fails to procure additional insurance, the OWNER shall have the right to purchase equivalent insurance coverage and charge the cost of that insurance against any amounts due the ENGINEER under the terms of this agreement.

Said insurance shall be written by a company or companies licensed to do business in the State of Oklahoma and satisfactory to the OWNER.

1.1.21. Drug-Free Workplace

1.1.21.1. Definitions. As used in this clause, “controlled substance” means a controlled substance in schedules I through V of section 202 of the Controlled Substance Act (21 U.S.C. 812) and as further defined in regulation 21 CFR 1308.11-1308.15. “conviction” means a finding of guilt (including a plea of nolo contendere) or imposition of sentence, or both, by any judicial body charged with the responsibility to determine violations of the federal or state criminal drug statutes. “criminal drug statute” means a federal or non-federal criminal statute involving manufacture, distribution, dispensing, possession or use of any controlled substance.

“Drug-free workplace” means the site(s) for the performance of work done by the ENGINEER in connection with a specific contract at which employees of the ENGINEER are prohibited from engaging in the unlawful manufacture, distribution, dispensing, possession, or use of a controlled substance.

“Employee” means an employee of the ENGINEER directly engaged in the performance of work under a government contract.

“Directly engaged” is defined to include all direct cost employees and any other employee who has other than a minimal impact or involvement in contract performance.

1.1.21.2. The ENGINEER, if other than an individual, shall within thirty (30) calendar days after authorization to proceed (unless a longer period is agreed to in writing) for contracts of thirty (30) calendar days or more performance duration; or as soon as possible for contracts of less than thirty (30) calendar days of performance duration.

1. Publish a statement notifying its employees that the unlawful manufacture, distribution, dispensing, possession, or use of a controlled substance is prohibited in the ENGINEER’s workplace and specifying the actions that will be taken against employees for violation of such prohibition.
2. Establish an ongoing drug-free awareness program to inform such employees about
 - (i) The dangers of drug abuse in the workplace.
 - (ii) The ENGINEER’s policy of maintaining a drug-free workplace.
 - (iii) Any available drug counseling, rehabilitation, and employee assistance programs; and
 - (iv) The penalties that may be imposed upon employees for drug abuse violations occurring in the workplace.

3. Provide all employees engaged in performance of the contract with a copy of the statement required by subparagraph 1.1.21.2.1. of this clause:
4. Notify such employees in writing of the statement required by subparagraph 1.1.21.2.1. of this clause, that as a condition of continued employment of this contract, the employee will
 - (i) Abide by the terms of the statement; and
 - (ii) Notify the employer in writing of the employee's conviction under a criminal drug statute for a violation occurring in the workplace no later than five (5) days after such conviction.
5. Notify the contracting officer in writing within ten (10) days after receiving notice under subdivision 1.1.21.2.4. (ii) of this clause from an employee or otherwise receiving actual notice of such conviction. The notice shall include the position title of the employee.
6. Within thirty (30) calendar days after receiving notice under subdivision 1.1.21.2.4. (ii) of this clause of a conviction, take one (1) of the following actions with respect to any employee who is convicted of a drug abuse violation occurring in the workplace.
 - (i) Take appropriate personnel action against such employee, up to and including termination; or
 - (ii) Require such employee to satisfactorily participate in a drug abuse assistance or rehabilitation program approved for such purposes by a Federal, State, or local health, law enforcement, or other appropriate agency.
7. Make a good faith effort to maintain a drug-free workplace through implementation of subparagraphs 1.1.21.2.1. through 1.1.21.2.6. of this clause.

1.1.21.3. The ENGINEER, if an individual, agrees by award of the contract or acceptance of a purchase order, not to engage in the unlawful manufacture, distribution, dispensing, possession, or use of a controlled substance in the performance of this contract.

1.1.21.4. In addition to other remedies available to the OWNER, the ENGINEER's failure to comply with the requirements of paragraphs 1.1.21.2. and 1.1.21.3. of this clause may, pursuant to FAR 23.506, render the ENGINEER subject to suspension of contract payment or termination of the contract for default.

1.2. Preliminary Design Phase

After written authorization to proceed with the Preliminary Design Phase, ENGINEER shall:

- 1.2.1. In consultation with the OWNER and on the basis of the Scope of Services (Exhibit "A"), prepare preliminary design documents consisting of final design criteria, preliminary plans, and outline specifications.
- 1.2.2. Based on the preliminary design plans, submit an opinion of probable cost for the project including construction cost, contingencies, and compensation for all professionals and consultant services.
- 1.2.3. Furnish three (3) copies of the above preliminary design plans and present and review them in person with the OWNER.

1.3. Final Design Phase

After written authorization to proceed with the Final Design Phase, ENGINEER shall:

- 1.3.1. On the basis of the accepted preliminary design plans, incorporate in the contract documents final plans, quantities, construction estimates, and specifications to show the character and scope of the work to be performed by the Contractors on the PROJECT.
- 1.3.2. Furnish to OWNER such documents and design data as may be required and assist in the preparation of the required documents so that the OWNER may obtain approvals of such governmental authorities as have jurisdiction over design criteria applicable to the PROJECT and assist in obtaining such approvals by participating in submissions to and negotiations with appropriate authorities.
- 1.3.3. Advise the OWNER of any adjustments to their latest opinion of probable project cost caused by changes in design requirements or construction costs and furnish a revised opinion of probable project cost based on the drawings and specifications.
- 1.3.4. Prepare bid forms, notice to bidders, instruction to bidders, general conditions and supplementary conditions, and assist in the preparation of other related documents.
- 1.3.5. Furnish three (3) copies of the above documents and present and review them in person with the OWNER.
- 1.3.6. Furnish five (5) copies of the approved final design documents to the OWNER.

- 1.3.7. Assist the OWNER in the acquisition of the required local, State, and Federal government permits (Health Department, ODOT, etc.) and private permits (railroad, utility, etc.). The ENGINEER shall at no additional cost to OWNER provide sets of construction plans and specifications as may be necessary for application of such permits.

1.4. Advertising and Bidding Phase

After written authorization to proceed with the Advertising and Bidding Phase, the ENGINEER shall:

- 1.4.1. Assist OWNER in obtaining bids or negotiating proposals for the construction contract. The ENGINEER shall supply prospective bidders with the project plans and contract documents for a fee to be retained by the ENGINEER to cover the costs for reproduction, etc.; the amount of the fee to be agreed upon by the ENGINEER and the OWNER. The ENGINEER shall record the name, address, telephone number, and email address of each prospective bidder obtaining the contract documents.
- 1.4.2. Attend the Pre-Bid Conference to assist the OWNER in answering any questions pertaining to the PROJECT which the prospective bidders may have.
- 1.4.3. Consult with and advise the OWNER as to the acceptability of subcontractors and other persons or organizations proposed by the Contractor(s) for those portions of the work as to which such acceptability is required by the contract documents.
- 1.4.4. Consult with and advise the OWNER as to the acceptability of substitute materials and equipment proposed by Contractor(s) when substitution is permitted by the contract documents.
- 1.4.5. Assist the OWNER in evaluating bids or proposals and in assembling and awarding contracts.

1.5. Construction Phase

During the Construction Phase, the ENGINEER shall:

- 1.5.1. Consult with and advise the OWNER and act as their representative. All of the OWNER's instructions to Contractor(s) will be issued through the Assistant City Manager or their designated representative.
- 1.5.2. Make monthly visits to the site to observe as an experienced and qualified design professional, the progress and quality of the executed work and to determine in general if the work is proceeding in accordance with the contract document; they shall not be required to make exhaustive or continuous on-site inspections to check the quality or quantity of work;

shall not be responsible for the means, methods, techniques, sequences or procedures of construction selected by Contractor(s) or the safety precautions and programs incident to the work of Contractor(s). Their efforts will be directed toward providing assurance for OWNER that the completed PROJECT will conform to the contract documents; but they shall not be responsible for the failure of Contractor(s) to perform construction work in accordance with the contract documents. During such visits and on the basis of their on-site observances, they shall provide the OWNER written reports on the progress, performance, and quality of the work. The ENGINEER shall endeavor to guard the OWNER against defects and deficiencies in the work of Contractor(s) and may recommend to OWNER the disapproval or rejection of work as failing to conform to the contract documents.

- 1.5.3. Review and approve shop drawings and samples, the results of tests and inspections and other data which any Contractor is required to submit, but only for conformance with the design concept of the PROJECT and compliance with the information given in the contract documents; determine the acceptability of substitute materials and equipment proposed by Contractor(s); and receive and review (for general content as required by the specifications) maintenance and operating instructions, schedules, guarantees, bonds and certificates of inspection which are to be assembled by Contractor(s) in accordance with the contract documents.
- 1.5.4. Conduct, when notified by OWNER, a final inspection of the project and provide the OWNER a written report indicating the ENGINEER's opinion as to the conformance of the completed work to the contract documents, quality of the work performed, performance of the Contractor(s) and a list of any deficient items.
- 1.5.5. Perform such additional services as may be set forth under this phase of the work as shown in Exhibit "A".

2. SECTION 2 - OWNER'S RESPONSIBILITIES

The OWNER shall:

- 2.1. Provide full information as to their requirements for the project.
- 2.2. Assist the ENGINEER by placing at their disposal all available information pertinent to the project including previous reports and any other data relative to design and construction of the PROJECT.
- 2.3. Examine all studies, reports, sketches, estimates, specifications, drawings, proposals, and other documents presented by the ENGINEER and render in writing decisions pertaining within a reasonable time so as not to delay the services of the ENGINEER.

- 2.4. Pay all advertising costs incident to obtaining bids or proposals from Contractor(s).
- 2.5. Return to the ENGINEER submitted project documents for OWNER's review on which the ENGINEER has not substantially addressed previously noted provisions and comments. The ENGINEER's contract time will not be suspended for submission of project documents which do not contain substantial revisions.
- 2.6. Provide a testing firm and pay all costs for testing, as required for design of the PROJECT, unless specified otherwise.
- 2.7. Designate in writing a person to act as the OWNER's representative with respect to the work to be performed under this agreement. Such person shall have complete authority to transmit instructions, receive information, and interpret and define the OWNER's policies and decisions with respect to materials, equipment, elements, and systems pertinent to the ENGINEER's services.
- 2.8. Issue all instructions to the ENGINEER; act as interpreter of the requirements of the contract documents and judge of the performance thereunder by the parties thereto and shall make decisions on all claims of the ENGINEER relating to the execution and progress of the work and all other matters and questions related thereto.
- 2.9. In consultation with the ENGINEER, issue all instructions to Contractor(s); prepare routine change orders as required; require, if deemed appropriate, special inspection or testing of the work; act as interpreter of the requirements of the contract documents and judge of the performance thereunder by the parties thereto and shall make decisions on all claims of the OWNER and Contractor(s) relating to the execution and progress of the work and all other matters and questions related thereto.
- 2.10. Have the Assistant City Manager or their designated representative, based on their on-site observations and project inspection reports, determine the amounts owing to Contractor(s).
- 2.11. Conduct an inspection to determine if the PROJECT is substantially complete and a final inspection to determine if the project has been completed in accordance with the contract documents and if each Contractor has fulfilled all obligations thereunder so that OWNER may approve, in writing, final payment to each Contractor.

3. SECTION 3 - PERIOD OF SERVICES

- 3.1. The provisions of 3.2. through 3.5. inclusive, and the various rates of compensation for the ENGINEER's services provided for elsewhere in this agreement have been agreed to in anticipation of the orderly and continuous progress of the PROJECT through completion of the Construction Phase. The ENGINEER's obligation to render services hereunder will extend for a period which may be reasonably required for the design, award of contracts, and construction of the PROJECT.
- 3.2. The PROJECT scope of services shall be completed by the schedule set forth in Exhibit "A" following authorization to proceed. This schedule assumes authorization to proceed is received in December 2023. Specific time frames and requirements for completion of various items within the basic scope of services shall be completed as specified in the following paragraphs:
 - 3.2.1. The services called for in the Preliminary Design Phase shall be completed by November 2024, in accordance with Exhibit "A".
 - 3.2.2. After acceptance by OWNER of the preliminary design plans, opinion of probable project cost, indicating any specific modifications or changes desired by the OWNER, and upon written authorization from the OWNER, the ENGINEER shall proceed with the performance of the services called for in the Final Design Phase, so as to deliver final contract documents and a revised opinion of project cost for all authorized work by August 2026.
 - 3.2.3. ENGINEER's services under the Preliminary Design Phase and Final Design Phase shall each be considered complete at the date when the submissions for that phase have been accepted and approved by the OWNER.
 - 3.2.4. After acceptance by the OWNER of the final construction plans and the ENGINEER's most recent opinion of probable project cost and upon written authorization to proceed, the ENGINEER shall proceed with performance of the services called for in the Advertising and Bidding Phase. This Phase shall terminate and the services to be rendered thereunder shall be considered complete upon award of the contract.
 - 3.2.5. The Construction Phase will commence with the execution of the awarded construction contract for the work of the PROJECT or any part thereof, and will terminate upon written approval by Assistant City Manager or their designated representative of final payment of the contract.
 - 3.2.6. In the event that the work of the project is to be performed under more than one contract, the OWNER and ENGINEER shall, prior to commencement of the Final Design Phase, develop a schedule for performance of the ENGINEER's services during the Final Design and Advertising and Bidding Phases in order to sequence and coordinate properly such services as applicable to the work under such separate contracts. This schedule is to

be prepared whether or not the work under such contracts is to proceed concurrently and is to be attached as an exhibit to and made a part of this agreement and the provisions of paragraphs 3.4. and 3.5. will be modified accordingly.

- 3.3. If OWNER has requested significant modifications or changes in the PROJECT, the time of performance of the ENGINEER's services shall be adjusted appropriately.
- 3.4. If ENGINEER is delayed at any time in the progress of any phase of the project by any act or neglect of the OWNER, or by any separate contractor employed by the OWNER, or by any act or neglect of regulatory agencies, or by labor disputes, fire, unusual delay in transportation, adverse weather conditions not reasonably anticipatable, unavoidable casualties, or any causes beyond the ENGINEER's control, then the Contract completion date shall be extended by Supplemental Agreement (Amendment) for a reasonable time equaling the amount of delay.
- 3.5. Waiver in Case of Delay. In the event of delay in proceeding with the work hereunder or any portion thereof, whether such delay be caused by the OWNER or any other agency, the ENGINEER hereby agrees that they will not exert any claim against the OWNER by reason of such delay, and all such claims are hereby waived.

4. SECTION 4 - PAYMENTS TO ENGINEER

4.1. Methods of Payment for Services of Engineer.

- 4.1.1. Services as a Witness. The OWNER will pay the ENGINEER for the services of the principals and employees as witnesses at the rate of \$220.00 per hour for a principal's time and \$170.00 per hour for a senior engineer or any portion thereof plus all reimbursable expenses, except that no payment shall be made for services as a witness in any case wherein the OWNER is an adverse party, to the ENGINEER.
- 4.1.2. For services described herewith, exclusive of fees for services as witnesses, the ENGINEER will be paid the fee(s) as outlined in Exhibit "B".

4.2. Times of Payment.

- 4.2.1. The ENGINEER shall submit monthly statements for services rendered. Compensation will be based on the ENGINEER's estimate of the proportion of the total services actually completed at the time of billing and agreed upon by the Assistant City Manager or their designated representative. The OWNER shall make prompt monthly payments in response to ENGINEER's monthly statements.
- 4.2.2. The OWNER shall, upon conclusion of the Preliminary Design, Final Design, Advertising and Bidding Phase, and Construction Phase services, pay according to the Phases and Unit Quantities set forth in Exhibit "B" Basis of Compensation.

Additional cost to the OWNER caused by error or omission of items in the construction documents will not be included in final construction cost for determination of the ENGINEER's fee unless the ENGINEER is instructed by the OWNER to prepare the additional contract documents to address the error or omission.

- 4.2.3. The ENGINEER shall submit to the OWNER, prior to commencement of the Advertising and Bidding Phase, Deliverables including digital files of the project in PDF format, relevant project drawings in CAD format, and specifications referenced in the final plans.
- 4.2.4. Prior to receiving final payment, the ENGINEER shall also submit to OWNER one (1) set of ½ size "As-Built Record Drawings" (hereinafter referred to as "As-Built") plans including digital files in PDF and CAD format. The "As-Built" drawings shall represent any changes that occurred during construction. The OWNER shall supply to the ENGINEER all changes that occurred during construction, in sufficient detail to allow the ENGINEER to prepare the "As-Built" drawings, unless the ENGINEER is responsible for construction management.

IN WITNESS WHEREOF, the parties hereto have executed this Agreement the day and year first above written.

On Behalf of the ENGINEER:

(FOR CORPORATIONS ONLY)

Name of Corporation

By _____
Title _____

ATTEST:

Title _____

(AFFIX SEAL)

(FOR PARTNERSHIPS AND PROPRIETORSHIPS)

TEIM DESIGN, PLLC
Name of Partnership or Proprietorship

By _____

Title _____

COUNTY OF CLEVELAND }
STATE OF OKLAHOMA }

Before me the undersigned, a Notary Public in and for said state, on this 19th day of December, 2023, personally appeared _____, a member of the partnership/proprietorship TEIM Design, PLLC to me known to be the identical person who executed the within and foregoing instrument on behalf of said partnership/proprietorship and acknowledged to me that _____ (he/she) executed the same as _____ (his/her) free and voluntary act and deed, and for the free and voluntary act and deed of said partnership/proprietorship, for the uses and purposes therein set forth.

Notary Public

My Commission Expires _____

CITY OF MOORE, OKLAHOMA
A Municipal Corporation

Glenn Lewis, MAYOR

ATTEST:

Vanessa Kemp, CITY CLERK

APPROVED as to form and legality on behalf of the City of Moore, Oklahoma, this
11th day of December, 2023.

Brian Miller, CITY ATTORNEY

EXHIBIT “A”

SCOPE OF SERVICES

CITY OF MOORE

N.W. 27th STREET RECONSTRUCTION PROJECT FROM HILLCREST AVENUE EXTENDING EAST TO THE I-35 SERVICE ROAD

SCOPE OF WORK

The Scope of Work shall include the services necessary for developing preliminary and final design plans for the reconstruction of N.W. 27th Street located in Ward 2 of the City of Moore. The project includes:

- Reconstruction of N.W. 27th Street as a four-lane arterial city street with two-way-left turn-lane (TWLTL) beginning at Hillcrest Avenue extending east approximately 1,600 ft. to the I-35 Service Road.
- Relocation of City of Moore owned public utilities as necessary by supplement.
- Utility Coordination with utility owners.

The project shall be designed in accordance with City of Moore Standard Details, as well as ODOT 2019 Standard Specifications for Highway Construction, where necessary. Proposed improvements shall be designed for 35 mph. Widening and/or reconstruction shall be in accordance with the City of Moore Arterial City Street Typical section for a 4-lane typical section with additional two way left turn lane (64’ wide section from face of curb to face of curb) along NW 27th Street. Striped medians will be utilized to channelize traffic where appropriate. Raised medians are anticipated near the southbound I-35 frontage road intersection. ADA compliant sidewalks/multi-use paths will be added along at least one side of NW 27th Street. Roadway hydraulic analysis will be performed on the existing storm sewer systems and improvements will be made as indicated by this analysis.

A. Roadway Design

1. Roadway design shall conform to current City of Moore Standard details as well as ODOT Standard Specifications for Highway Construction, along with other standards and acceptable practices.
2. Prepare preliminary design plans and field review inspections.
3. Show existing and provide proposed and/or temporary right-of-way necessary or easements for the construction of the project and utility corridors.
4. Perform quality control review, make necessary corrections, and submit final plans.
5. Prepare construction cost estimates at each major submission milestone and update as requested.

6. Provide construction sequencing and phasing. Construction shall be phased under traffic one side at a time, with at least one lane open to traffic in each direction at all times.
7. Provide roadway hydraulics and design of drainage structures, including storm sewer design, where necessary. Design shall accommodate the Q_{50} within the roadway and the Q_{100} within the right-of-way.
8. Utilize City of Moore “Arterial City Street”, “Arterial Boulevard City Street”, and “Local City Street” typical sections.
9. Provide Storm Water Management Plan (SWMP) for roadway construction.
10. Prepare final roadway construction plans including, but not limited to:
 - a. Title sheet
 - b. Typical sections and details
 - c. Plan notes and summary of pay quantities
 - d. Summary schedules
 - e. Drainage Maps
 - f. Geometric layout and traffic data
 - g. Plan and Profile sheets (1” = 50’ max., including overlap)
 - h. Construction phasing
 - i. SWMP, construction erosion control plans
 - j. Geometric data sheets
 - k. Special detail sheets
 - l. Special drainage structure details
 - m. Survey Data Sheets
 - n. Cross sections
11. Provide legal descriptions and exhibits for any proposed right-of-way required for the project. Right-of-way acquisition services are not included in the scope of this work.

B. Utility Coordination

1. Engineer will conduct a drive-out and inspection of the project, utilizing any SUE data available to identify utilities present and field verify SUE data, and carry out tasks in accordance with any special instructions which may be furnished by the City of Moore.
2. Represent the City of Moore on the aforementioned project implementing the requirements as outlined by the City, with the use of the Oklahoma Department of Transportation’s Utilities Branch Policies and procedures as appropriate. The Engineer will be responsible for preparing written correspondence, conducting field meetings and /or hold conversations with utility owners/representatives that are within the project extents. The engineer’s decisions must be in accordance with City’s current policies and procedures, state statutes and federal statutes. The engineer is expected to use sound judgement in determining the most acceptable method (for owner and utility owner) of relocation of affected utilities, using due care regarding the City’s betterment/reimbursement policy.
3. Furnish the owner with electronic copies of all correspondence handled by the engineer on this project. The consultant will work with the City of Moore and utility owners

within the project extents to develop utility corridors which clear construction of the proposed improvements.

4. The Engineer will review preliminary plans for conformance to the City's policies and procedures and attend the plan in hand meeting offering comments to ensure adequate right-of-way for compliance with the City's utilities procedures.
5. If required, the following will be provided by supplement:
 - a. Provide utility relocation cost estimates for each utility conflicting with the proposed improvements as provided by each utility owner, including an analysis of the percentage to be paid by the City for each conflicting utility. This will culminate in a total utility programming cost estimate depicting each utility and the anticipated costs associated.
 - b. Assist the City with the releasing of utility clearance work orders.

C. Traffic Design

1. Provide all temporary and permanent traffic control design, including signing and striping details where necessary. Design shall be in accordance with current design standards and MUTCD guidelines.
2. Final traffic plans will include, but not limited to:
 - a. Construction traffic control plan sheets, notes, and pay quantities
 - b. Permanent signing and striping plan sheets, notes, and pay quantities as required by the City of Moore.

D. Survey

1. The scope and coverage of the field survey shall be made in accordance with any available City of Moore policies and procedures for land surveys.
2. LiDAR survey of the project within the limits specified including survey of all storm sewer and other drainage structures to their outlet into an open channel.
3. Limits of Survey on each project are described below:
 - N.W. 27th St beginning at west side of Hillcrest Avenue extending east to the east side of the southbound I-35 frontage road.
 - Approximately 200' wide by approximately 1,750 ft. of survey required.
 - Shall include all intersections with local streets not specifically called out beyond the radius of the street return to ensure enough survey is available to obtain ADA compliance.

Survey to extend a minimum of 100' left and right of centerline or to building fronts whichever is closer. The front faces of trees, shrubs, buildings, and other features shall be identified. Types of mailboxes and posts shall be identified as appropriate.

Figures illustrating the survey boundary for each project are provided following the scope.

E. Subsurface Utility Engineering (SUE) Quality Level B (QL-B)

2. Services will include:
 - a. Research of existing utilities.
 - b. Verify utility depths as directed by the engineer for the purpose of determining if utility conflicts exist with the proposed improvements.
 - c. Field exploration and location/identification of utilities present within the project extents. Utility locations will be provided to the engineer via CAD file tied to the survey.
 - d. Potholing as necessary to identify location horizontally and vertically. Potholes to be included in the cost of SUE.
3. Work shall be done in accordance with generally accepted practices.

F. Geotechnical Studies

1. Perform geotechnical work in accordance with "State of Oklahoma Department of Transportation Geotechnical Specifications for Roadway Design" (June 29, 2011), including:
 - a. Existing Pavement Survey: In the existing lanes the pavement will be cored, and Dynamic Cone Penetrometer (DCP) testing shall be performed in order to establish a CBR for the sub-grade. These cores will be on NW 27th Street located at approximate centerline at the following locations:
 - i. 500 ft. east of Hillcrest Avenue near Woodlawn Drive.
 - ii. 500 ft. west of the southbound I-35 Service Road near Poplar Drive.

In summary, a total of 2 cores of the existing pavement will be required. Existing pavement and base will be identified by thickness and type. Borings will be sampled to a depth of 24 inches, consisting of a sample in the top 6 inches and the bottom 18 inches. These samples will be tested for soil classification and soluble sulfates.
 - b. Subgrade and Pavement Recommendations: Subgrade and pavement recommendations will be provided in accordance with approved ODOT policies. The City of Moore will be contacted to discuss any geotechnical recommendations which might differ from the standard details to be utilized on each project. Based on information provided in the geotechnical report, City input, and final scoping/design decisions, the final pavement design will be confirmed. The pavement design will consist of either a concrete section anticipated to consist of a minimum of 9 inches of Dowel Jointed P.C. Pavement over 3 inches Asphalt over a stabilized subgrade, or an asphalt section consisting of a minimum of 11 inches of asphalt over a stabilized subgrade.

2. The Geotechnical work will be completed after a notice to proceed is issued by the City of Moore. The Geotechnical Consultant will submit the proposed sampling and drilling plan prior to mobilization. The proposed sampling and drilling plan will be on an aerial map showing the proposed access path locations and boring points, clearly shown at an appropriate scale (1"=50 ft or larger is preferred).

The Geotechnical Consultant shall notify the City of Moore prior to performing any field work. All work shall be performed within the existing City street right-of-way during off peak hours. The Geotechnical Consultant shall be responsible for restoring the pavement to the conditions existing prior to field work. These include but are not restricted to filling holes with a like material as the pavement surface.

G. Permits

1. This project does not appear to be located near any blue line streams. No 404 permitting is anticipated. If any 404 permitting is required, it will be submitted and approved prior to construction of the proposed improvements.
2. The project is located in an "area of minimal flood hazard" according to the FEMA Floodplain map. Any modifications to the drainage configuration which will affect the floodplain will be permitted as appropriate. No change is anticipated.
3. The Consultant will complete an Oklahoma Water Resource Board Permit Application if necessary.
4. The Consultant shall complete the Department of Environmental Quality (DEQ) Notice of Intent (NOI) form at the time of submittal of final plans and cost estimate.

H. Advertising, Bidding Services, & Construction Administration

1. Assist the City of Moore in the advertising and bidding of the project by doing the following:
 - a. Submit an Engineer's estimate of the construction cost for the project to the City of Moore a minimum of 28 days prior to the advertised bid opening date. Provide an updated estimate 7 days prior to the bid opening date, if necessary.
 - b. Provide 11"x17" black and white copies of plan sheets to prospective bidders as directed by the City of Moore.
 - c. Maintain the Plan-holder's list. Provide a copy of the Plan-holder's list to the City three (3) days prior to the Bid Opening.
 - d. Assist in the correct interpretation of the plans and specifications to any interested party.
 - e. Attend the pre-bid conference and generate a summary of the conference. Provide summary to the City within one (1) business day.
 - f. Issue addenda, as needed.

- g. Evaluate the bids and make recommendations to the City for award of the contract in compliance with applicable Oklahoma statutes.
- 2. Attend the pre-work conference, answer any Contractor questions relative to the plans, and generate a summary of the conference. Provide summary to the City within one (1) business day.
- 3. Schedule monthly site visits to the project locations for general inspections and observations during the construction stage and an additional one (1) day for the project's final inspection. If required by the City, provide a written report of each site visit including a summary of any corrective work to be performed.
- 4. If required, review and approve the contractor's shop drawings and all submittals including mix designs to ensure compliance with plans, specifications, and other contract documents.
- 5. Within three (3) business days of receipt, respond to request for information (RFI's) from the City's construction contractor for the above-described projects.
- 6. Within two (2) weeks of the final inspection, deliver ten (10) copies of the Report of Findings to the City. Supplement the Report with photos. The report shall include a summary of issues encountered, if any, and how the issues were resolved.

I. City of Moore Responsibilities

- 1. Make available as-built plans and city utility atlases.
- 2. Make available design traffic data, design speed, collision history, and other relevant design criteria.
- 3. Make available the latest changes to design policies, specifications, standards, etc.
- 4. Attend reviews.

J. Meetings and Milestones

- | | | |
|----|--------------------------------|---------------|
| 1. | Notice to Proceed | December 2023 |
| 2. | Complete Survey | February 2024 |
| 3. | Submit Preliminary Plans (50%) | November 2024 |
| 4. | Submit Final Plans (100%) | August 2026 |
| 5. | Advertising | November 2026 |

EXHIBIT "B"

BASIS OF COMPENSATION

**N.W. 27th STREET RECONSTRUCTION PROJECT FROM HILLCREST AVENUE EXTENDING EAST
TO THE
I-35 SERVICE ROAD**

Preliminary Plans			
a. Roadway	TEIM	\$104,780.00	LS
b. Traffic Control	TEC	\$6,250.00	LS
		Subtotal	\$111,030.00 LS
Final Plans			
a. Roadway	TEIM	\$69,860.00	LS
b. Traffic Control	TEC	\$6,250.00	LS
c. Traffic Signing & Striping	TEC	\$6,500.00	LS
		Subtotal	\$82,610.00 LS
Survey	CEC	\$22,000.00	LS
SUE	CEC	\$16,000.00	LS
Advertising, Bidding, Review, & Site Visits	TEIM	\$10,000.00	LS
Geotechnical	Standard Testing	\$2,600.00	Unit Cost
		Total	\$ 244,240.00 LS



**Agreement
For
Professional Services
City of Moore, Oklahoma
Project No. 2300804**



Contents

RECITALS	1
1. DEFINITIONS	1
2. SCOPE OF SERVICES	1
3. PAYMENT	2
4. AMENDMENTS	2
5. OWNER'S RESPONSIBILITIES.....	2
6. GENERAL REQUIREMENTS	3
7. INSURANCE.....	6
8. DOCUMENTS.....	6
9. INDEMNIFICATION / WAIVERS	6
10. DISPUTE RESOLUTION	7
11. TERMINATION	9
12. MISCELLANEOUS	9
13. EXHIBITS	10



THIS PROFESSIONAL SERVICES AGREEMENT (“Agreement”) is made as of the Effective Date by and between the **City of Moore, Oklahoma** hereinafter referred to as **“Owner”**), and **Garver, LLC** (hereinafter referred to as **“Garver”**). Owner and Garver may individually be referred to herein after as a **“Party”** and/or **“Parties”** respectively.

RECITALS

WHEREAS, Owner intends to widen Eastern Avenue from NE 12th Street to NE 27th Street to include roadway, storm sewer, and pedestrian improvements (the **“Project”**).

WHEREAS, Garver will provide professional Services related to the Project as further described herein.

NOW THEREFORE, in consideration of the mutual covenants herein contained and other good and valuable consideration, the receipt and adequacy of which are hereby acknowledged, the Parties agree as follows:

1. DEFINITIONS

In addition to other defined terms used throughout this Agreement, when used herein, the following capitalized terms have the meaning specified in this Section:

“Effective Date” means the date last set forth in the signature lines below.

“Damages” means any and all damages, liabilities, or costs (including reasonable attorneys’ fees recoverable under applicable law).

“Hazardous Materials” means any substance that, under applicable law, is considered to be hazardous or toxic or is or may be required to be remediated, including: (i) any petroleum or petroleum products, radioactive materials, asbestos in any form that is or could become friable, (ii) any chemicals, materials or substances which are now or hereafter become defined as or included in the definition of “hazardous substances,” “hazardous wastes,” “hazardous materials,” “extremely hazardous wastes,” “restricted hazardous wastes,” “toxic substances,” “toxic pollutants,” or any words of similar import pursuant to applicable law; or (iii) any other chemical, material, substance or waste, exposure to which is now or hereafter prohibited, limited or regulated by any governmental instrumentality, or which may be the subject of liability for damages, costs or remediation.

“Personnel” means affiliates, directors, officers, partners, members, employees, and agents.

2. SCOPE OF SERVICES

2.1. Services. Owner hereby engages Garver to perform the scope of service described in Exhibit A attached hereto (**“Services”**). Execution of this Agreement by Owner constitutes Owner’s written authorization to proceed with the Services. In consideration for such Services, Owner agrees to pay Garver in accordance with Section 3 below.



3. PAYMENT

- 3.1. Fee. For the Services described under Section 2.1, Owner will pay Garver in accordance with this Section 3 and Exhibit B. Owner represents that funding sources are in place with the available funds necessary to pay Garver in accordance with the terms of this Agreement.
- 3.2. Invoicing Statements. Garver shall invoice Owner on a monthly basis. Such invoice shall include supporting documentation reasonably necessary for Owner to know with reasonable certainty the proportion of Services accomplished. The Owner's terms and conditions set forth in a purchase order (or any similar document) are expressly rejected.
- 3.3. Payment.
 - 3.3.1. Due Date. Owner shall pay Garver all undisputed amounts within thirty (30) days after receipt of an invoice. Owner shall provide notice in writing of any portion of an invoice that is disputed in good faith within fifteen (15) days of receipt of an invoice. Garver shall promptly work to resolve any and all items identified by Owner relating to the disputed invoice. All disputed portions shall be paid promptly upon resolution of the underlying dispute.
 - 3.3.2. If any undisputed payment due Garver under this Agreement is not received within forty-five (45) days from the date of an invoice, Garver may elect to suspend Services under this Agreement without penalty.
 - 3.3.3. Payments due and owing that are not received within thirty (30) days of an invoice date will be subject to interest at the lesser of a one percent (1%) monthly interest charge (compounded) or the highest interest rate permitted by applicable law.

4. AMENDMENTS

- 4.1. Amendments. Garver shall be entitled to an equitable adjustment in the cost and/or schedule for circumstances outside the reasonable control of Garver, including modifications in the scope of Services, applicable law, codes, or standards after the Effective Date ("Amendment"). As soon as reasonably possible, Garver shall forward a formal Amendment, in the form set forth in Exhibit D, to Owner with backup supporting the Amendment. All Amendments should include, to the extent known and available under the circumstances, documentation sufficient to enable Owner to determine: (i) the factors necessitating the possibility of a change; (ii) the impact which the change is likely to have on the cost to perform the Services; and (iii) the impact which the change is likely to have on the schedule. All Amendments shall be effective only after being signed by the designated representatives of both Parties. Garver shall have no obligation to perform any additional services created by such Amendment until a mutually agreeable Amendment is executed by both Parties.

5. OWNER'S RESPONSIBILITIES

- 5.1. In connection with the Project, Owner's responsibilities shall include the following:
 - 5.1.1. Those responsibilities set forth in Exhibit A.
 - 5.1.2. Owner shall be responsible for all requirements and instructions that it furnishes to Garver pursuant to this Agreement, and for the accuracy and completeness of all programs, reports, data, and other information furnished by Owner to Garver pursuant to this



Agreement. Garver may use and rely upon such requirements, programs, instructions, reports, data, and information in performing or furnishing services under this Agreement, subject to any express limitations or reservations applicable to the furnished items as further set forth in Exhibit A.

5.1.3. Owner shall give prompt written notice to Garver whenever Owner observes or otherwise becomes aware of the presence at the Project site of any Hazardous Materials or any relevant, material defect, or nonconformance in: (i) the Services; (ii) the performance by any contractor providing or otherwise performing construction services related to the Project; or (iii) Owner's performance of its responsibilities under this Agreement.

5.1.4. Owner shall include "Garver, LLC" as an indemnified party under the contractor's indemnity obligations included in the construction contract documents.

5.1.5. Owner will not directly or indirectly solicit any of Garver's Personnel during performance of this Agreement and for a period of one (1) year beyond completion of this Agreement.

6. GENERAL REQUIREMENTS

6.1. Standards of Performance.

6.1.1. Industry Practice. Garver shall perform any and all Services required herein in accordance with generally accepted practices and standards employed by the applicable United States professional services industries as of the Effective Date practicing under similar conditions and locale. Such generally accepted practices and standards are not intended to be limited to the optimum practices, methods, techniques, or standards to the exclusion of all others, but rather to a spectrum of reasonable and prudent practices employed by the United States professional services industry.

6.1.2. Owner shall not be responsible for discovering deficiencies in the technical accuracy of Garver's services. Garver shall promptly correct deficiencies in technical accuracy without the need for an Amendment unless such corrective action is directly attributable to deficiencies in Owner-furnished information.

6.1.3. On-site Services. Garver and its representatives shall comply with Owner's and its separate contractor's Project-specific safety programs, which have been provided to Garver in writing in advance of any site visits.

6.1.4. Relied Upon Information. Garver may use or rely upon design elements and information ordinarily or customarily furnished by others including, but not limited to, specialty contractors, manufacturers, suppliers, and the publishers of technical standards.

6.1.5. Aside from Garver's direct subconsultants, Garver shall not at any time supervise, direct, control, or have authority over any contractor's work, nor shall Garver have authority over or be responsible for the means, methods, techniques, sequences, or procedures of construction selected or used by any such contractor, or the safety precautions and programs incident thereto, for security or safety at the Project site, nor for any failure of a contractor to comply with laws and regulations applicable to that contractor's services. Garver shall not be responsible for the acts or omissions of any contractor for whom it does not have a direct contract. Garver neither guarantees the performance of any contractor nor assumes responsibility for any contractor's failure to furnish and perform



its work in accordance with the construction contract documents applicable to the contractor's work, even when Garver is performing construction phase services.

6.1.6. In no event is Garver acting as a "municipal advisor" as set forth in the Dodd-Frank Wall Street Reform and Consumer Protection Act (2010) or the municipal advisor registration rules issued by the Securities and Exchange Commission. Garver's Services expressly do not include providing advice pertaining to insurance, legal, finance, surety-bonding, or similar services.

6.2. Instruments of Service.

6.2.1. Deliverables. All reports, specifications, record drawings, models, data, and all other information provided by Garver or its subconsultants, which is required to be delivered to Owner under Exhibit A (the "**Deliverables**"), shall become the property of Owner subject to the terms and conditions stated herein. Notwithstanding anything in this Agreement to the contrary, Garver shall have no obligation to deliver the Deliverables to Owner until payment has been received for the same.

6.2.2. Electronic Media. Owner hereby agrees that all electronic media, including CADD files ("**Electronic Media**"), are tools used solely for the preparation of the Deliverables. Upon Owner's written request, Garver will furnish to Owner copies of Electronic Media to the extent included as part of the Services. In the event of an inconsistency or conflict in the content between the Deliverables and the Electronic Media, however, the Deliverables shall take precedence in all respects. Electronic Media is furnished without guarantee of compatibility with the Owner's software or hardware. Because Electronic Media can be altered, either intentionally or unintentionally, by transcription, machine error, environmental factors, or by operators, it is agreed that, to the extent permitted by applicable law, Owner shall indemnify and hold Garver, Garver's subconsultants, and their Personnel harmless from and against any and all claims, liabilities, damages, losses, and costs, including, but not limited to, costs of defense arising out of changes or modifications to the Electronic Media form in Owner's possession or released to others by Owner. Garver's sole responsibility and liability for Electronic Media is to furnish a replacement for any non-functioning Electronic Media for reasons solely attributable to Garver within thirty (30) days after delivery to Owner.

6.2.3. Property Rights. All intellectual property rights of a Party, including copyright, patent, and reuse ("**Intellectual Property**"), shall remain the Intellectual Property of that Party. Garver shall obtain all necessary Intellectual Property from any necessary third parties in order to execute the Services. Any Intellectual Property of Garver or any third party embedded in the Deliverables shall remain so imbedded and may not be separated therefrom.

6.2.4. License. Upon Owner fulfilling its payment obligations under this Agreement, Garver hereby grants Owner a license to use the Intellectual Property, but only in the operation and maintenance of the Project for which it was provided. Use of such Intellectual Property for modification, extension, or expansion of this Project or on any other project, unless under the direction of Garver, shall be without liability to Garver and Garver's subconsultants. To the extent permitted by applicable law, Owner shall indemnify and hold Garver, Garver's subconsultants, and their Personnel harmless from and against any and all claims, liabilities, damages, losses, and costs, including but not limited to costs of defense arising out of Owner's use of the Intellectual Property contrary to the rights permitted herein.



6.3. Opinions of Cost.

6.3.1. Since Garver has no control over: (i) the cost of labor, materials, equipment, or services furnished by others; (ii) the contractor or its subcontractor(s)' methods of determining prices; (iii) competitive bidding; (iv) market conditions; or (v) similar material factors, Garver's opinions of Project costs or construction costs provided pursuant to Exhibit A, if any, are to be made on the basis of Garver's experience and qualifications and represent Garver's reasonable judgment as an experienced and qualified professional engineering firm, familiar with the construction industry. Garver cannot and does not guarantee that proposals, bids, or actual Project or construction costs will not vary from estimates prepared by Garver.

6.3.2. Owner understands that the construction cost estimates developed by Garver do not establish a limit for the construction contract amount. If the actual amount of the low construction bid or resulting construction contract exceeds the construction budget established by Owner, Garver will not be required to re-design the Services without additional compensation. In the event Owner requires greater assurances as to probable construction cost, then Owner agrees to obtain an independent cost estimate.

6.4. Underground Utilities. Except to the extent expressly included as part of the Services, Garver will not provide research regarding utilities or survey utilities located and marked by their owners. Furthermore, since many utility companies typically will not locate and mark their underground facilities prior to notice of excavation, Garver is not responsible for knowing whether underground utilities are present or knowing the exact location of such utilities for design and cost estimating purposes. In no event is Garver responsible for damage to underground utilities, unmarked or improperly marked, caused by geotechnical conditions, potholing, construction, or other contractors or subcontractors working under a subcontract to this Agreement.

6.5. Design without Construction Phase Services.

6.5.1. If the Owner requests in writing that Garver provide any specific construction phase services or assistance with resolving disputes or other subcontractor related issues, and if Garver agrees to provide such services, then Garver shall be compensated for the services as an Amendment in accordance with Sections 4 and 10.2.

6.6. Hazardous Materials. Nothing in this Agreement shall be construed or interpreted as requiring Garver to assume any role in the identification, evaluation, treatment, storage, disposal, or transportation of any Hazardous Materials. Notwithstanding any other provision to the contrary in this Agreement and to the fullest extent permitted by law, Owner shall indemnify and hold Garver and Garver's subconsultants, and their Personnel harmless from and against any and all losses which arise out of the performance of the Services and relating to the regulation and/or protection of the environment including without limitation, losses incurred in connection with characterization, handling, transportation, storage, removal, remediation, disturbance, or disposal of Hazardous Material, whether above or below ground.

6.7. Confidentiality. Owner and Garver shall consider: (i) all information provided by the other Party that is marked as "Confidential Information" or "Proprietary Information" or identified as confidential pursuant to this Section 6.7 in writing promptly after being disclosed verbally; and (ii) all documents resulting from Garver's performance of Services to be Confidential Information. Except as legally required, Confidential Information shall not be discussed with



or transmitted to any third parties, except on a “need to know basis” with equal or greater confidentiality protection or written consent of the disclosing Party. Confidential Information shall not include and nothing herein shall limit either Party’s right to disclose any information provided hereunder which: (i) was or becomes generally available to the public, other than as a result of a disclosure by the receiving Party or its Personnel; (ii) was or becomes available to the receiving Party or its representatives on a non-confidential basis, provided that the source of the information is not bound by a confidentiality agreement or otherwise prohibited from transmitting such information by a contractual, legal, or fiduciary duty; (iii) was independently developed by the receiving Party without the use of any Confidential Information of the disclosing Party; or (iv) is required to be disclosed by applicable law or a court order. All confidentiality obligations hereunder shall expire three (3) years after completion of the Services. Nothing herein shall be interpreted as prohibiting Garver from disclosing general information regarding the Project for future marketing purposes.

7. INSURANCE

7.1. Insurance.

7.1.1. Garver shall procure and maintain insurance as set forth in Exhibit C until completion of the Service. Upon request, Garver shall name Owner as an additional insured on Garver’s General Liability policy to the extent of Garver’s indemnity obligations provided in Section 9 of this Agreement.

7.1.2. Upon request, Garver shall furnish Owner a certificate of insurance evidencing the insurance coverages required in Exhibit C.

8. DOCUMENTS

8.1. Audit. Garver shall maintain all required records for the later of three (3) years after completion of the Services or Owner makes final payment and all other pending matters are closed.

8.2. Delivery. After completion of the Project, and prior to final payment, Garver shall deliver to the Owner all original documentation prepared under this Agreement, and one (1) set of the record drawing construction plans updated to reflect changes.

9. INDEMNIFICATION / WAIVERS

9.1. Indemnification.

9.1.1. Garver Indemnity. Subject to the limitations of liability set forth in Section 9.2, Garver agrees to indemnify and hold Owner, and Owner’s Personnel harmless from Damages due to bodily injury (including death) or third-party tangible property damage to the extent such Damages are caused by the negligent acts, errors, or omissions of Garver or any other party for whom Garver is legally liable, in the performance of the Services under this Agreement.

9.1.2. Owner Indemnity. Subject to the limitations of liability set forth in Section 9.2, Owner agrees to indemnify and hold Garver and Garver’s subconsultants and their Personnel harmless from Damages due to bodily injury (including death) or third-party tangible property damage to the extent caused by the negligent acts, errors, or omissions of Owner or any other party for whom Owner is legally liable, in the performance of Owner’s obligations under this Agreement.



9.1.3. In the event claims or Damages are found to be caused by the joint or concurrent negligence of Garver and the Owner, they shall be borne by each Party in proportion to its own negligence.

9.2. Waivers. Notwithstanding any other provision to the contrary, the Parties agree as follows:

9.2.1. The Parties agree that any claim or suit for Damages made or filed against the other Party will be made or filed solely against Garver or Owner respectively, or their successors or assigns, and that no Personnel shall be personally liable for Damages under any circumstances.

9.2.2. Mutual Waiver. To the fullest extent permitted by law, neither Owner, Garver, nor their respective Personnel shall be liable for any consequential, special, incidental, indirect, punitive, or exemplary damages, or damages arising from or in connection with loss of use, loss of revenue or profit (actual or anticipated), loss by reason of shutdown or non-operation, increased cost of construction, cost of capital, cost of replacement power or customer claims, and Owner hereby releases Garver, and Garver releases Owner, from any such liability.

9.2.3. Limitation. In recognition of the relative risks and benefits of the Project to both the Owner and Garver, Owner hereby agrees that Garver's and its Personnel's total liability under the Agreement shall be limited to one hundred percent (100%) of Garver's fee set forth in Exhibit B.

9.2.4. No Other Warranties. No other warranties or causes of action of any kind, whether statutory, express or implied (including all warranties of merchantability and fitness for a particular purpose and all warranties arising from course of dealing or usage of trade) shall apply. Owner's exclusive remedies and Garver's only obligations arising out of or in connection with defective Services (patent, latent or otherwise), whether based in contract, in tort (including negligence and strict liability), or otherwise, shall be those stated in the Agreement.

9.2.5. The limitations set forth in Section 9.2 apply regardless of whether the claim is based in contract, tort, or negligence including gross negligence, strict liability, warranty, indemnity, error and omission, or any other cause whatsoever.

10. DISPUTE RESOLUTION

10.1. Any controversy or claim ("**Dispute**") arising out of or relating to this Agreement or the breach thereof shall be resolved in accordance with the following:

10.1.1. Any Dispute that cannot be resolved by the project managers of Owner and Garver may, at the request of either Party, be referred to the senior management of each Party. If the senior management of the Parties cannot resolve the Dispute within thirty (30) days after such request for referral, then either Party may request mediation. If both Parties agree to mediation, it shall be scheduled at a mutually agreeable time and place with a mediator agreed to by the Parties. Should mediation fail, should either Party refuse to participate in mediation, or should the scheduling of mediation be impractical, either Party may file for arbitration in lieu of litigation.



- 10.1.2. Arbitration of the Dispute shall be administered by the American Arbitration Association (“AAA”) in accordance with its Construction Industry Arbitration Rules. EACH PARTY IRREVOCABLY WAIVES, TO THE FULLEST EXTENT PERMITTED BY APPLICABLE LAWS, ANY AND ALL RIGHT TO TRIAL BY JURY. The arbitration shall be conducted by a single arbitrator, agreed to by the Parties. In no event may a demand for arbitration be made if the institution of legal or equitable proceedings based on such dispute is barred by the applicable statute of limitations.
- 10.1.3. The site of the arbitration shall be Oklahoma. Each Party hereby consents to the jurisdiction of the federal and state courts within whose district the site of arbitration is located for purposes of enforcement of this arbitration provision, for provisional relief in aid of arbitration, and for enforcement of any award issued by the arbitrator.
- 10.1.4. To avoid multiple proceedings and the possibility of inconsistent results, either Party may seek to join third parties with an interest in the outcome of the arbitration or to consolidate arbitration under this Agreement with another arbitration. Within thirty (30) days of receiving written notice of such a joinder or consolidation, the other Party may object. In the event of such an objection, the arbitrator shall decide whether the third party may be joined and/or whether the arbitrations may be consolidated. The arbitrator shall consider whether any entity will suffer prejudice as a result of or denial of the proposed joinder or consolidation, whether the Parties may achieve complete relief in the absence of the proposed joinder or consolidation, and any other factors which the arbitrators conclude should factor on the decision.
- 10.1.5. The arbitrator shall have no authority to award punitive damages. Any award, order or judgment pursuant to the arbitration is final and may be entered and enforced in any court of competent jurisdiction.
- 10.1.6. The prevailing Party shall be entitled to recover its attorneys’ fees, costs, and expenses, including arbitrator fees and costs and AAA fees and costs.
- 10.1.7. The foregoing arbitration provisions shall be final and binding, construed and enforced in accordance with the Federal Arbitration Act, notwithstanding the provisions of this Agreement specifying the application of other law. Pending resolution of any Dispute, unless the Agreement is otherwise terminated, Garver shall continue to perform the Services under this Agreement that are not the subject of the Dispute, and Owner shall continue to make all payments required under this Agreement that are not the subject of the Dispute.
- 10.1.8. Owner and Garver further agree to use commercially reasonable efforts to include a similar dispute resolution provision in all agreements with independent contractors and subconsultants retained for the Project.
- 10.1. Litigation Assistance. This Agreement does not include costs of Garver for required or requested assistance to support, prepare, document, bring, defend, or assist in litigation undertaken or defended by Owner, unless litigation assistance has been expressly included as part of Services. In the event Owner requests such services of Garver, this Agreement shall be amended in writing by both Owner and Garver to account for the additional services and resulting cost in accordance with Section 4.



11. TERMINATION

- 11.1. Termination for Convenience. Owner shall have the right at its sole discretion to terminate this Agreement for convenience at any time upon giving Garver ten (10) days' written notice. In the event of a termination for convenience, Garver shall bring any ongoing Services to an orderly cessation. Owner shall compensate Garver in accordance with Exhibit B for: (i) all Services performed and reasonable costs incurred by Garver on or before Garver's receipt of the termination notice, including all outstanding and unpaid invoices, (ii) all costs reasonably incurred to bring such Services to an orderly cessation; and (iii) a cancellation fee equal to five percent (5%) of the value of the unperformed Services as a direct result of the termination.
- 11.2. Termination for Cause. This Agreement may be terminated by either Party in the event of failure by the other Party to perform any material obligation in accordance with the terms hereof. Prior to termination of this Agreement for cause, the terminating Party shall provide at least seven (7) business days written notice and a reasonable opportunity to cure to the non-performing Party. In all events of termination for cause due to an event of default by the Owner, Owner shall pay Garver for all Services properly performed prior to such termination in accordance with the terms, conditions and rates set forth in this Agreement.
- 11.3. Termination in the Event of Bankruptcy. Either Party may terminate this Agreement immediately upon notice to the other Party, and without incurring any liability, if the non-terminating Party has: (i) been adjudicated bankrupt; (ii) filed a voluntary petition in bankruptcy or had an involuntary petition filed against it in bankruptcy; (iii) made an assignment for the benefit of creditors; (iv) had a trustee or receiver appointed for it; (v) becomes insolvent; or (vi) any part of its property is put under receivership.

12. MISCELLANEOUS

- 12.1. Governing Law. This Agreement is governed by the laws of the State of Oklahoma, without regard to its choice of law provisions.
- 12.2. Successors and Assigns. Owner and Garver each bind themselves and their successors, executors, administrators, and assigns of such other party, in respect to all covenants of this Agreement; neither Owner nor Garver shall assign, sublet, or transfer their interest in this Agreement without the written consent of the other, which shall not be unreasonably withheld or delayed.
- 12.3. Independent Contractor. Garver is and at all times shall be deemed an independent contractor in the performance of the Services under this Agreement.
- 12.4. No Third-Party Beneficiaries. Nothing herein shall be construed to give any rights or benefits hereunder to anyone other than Owner and Garver. This Agreement does not contemplate any third-party beneficiaries.
- 12.5. Entire Agreement. This Agreement constitutes the entire agreement between Owner and Garver and supersedes all prior written or oral understandings and shall be interpreted as having been drafted by both Parties. This Agreement may be amended, supplemented, or modified only in writing by and executed by both Parties.



12.6. Severance. The illegality, unenforceability, or occurrence of any other event rendering a portion or provision of this Agreement void shall in no way affect the validity or enforceability of any other portion or provision of the Agreement. Any void provision of this Agreement shall be construed and enforced as if the Agreement did not contain the particular portion or provision held to be void.

12.7. Counterpart Execution. This Agreement may be executed in any number of counterparts, each of which shall be deemed to be an original and all of which taken together constitute one Agreement. Delivery of an executed counterpart of this Agreement by fax or transmitted electronically in legible form, shall be equally effective as delivery of a manually executed counterpart of this Agreement.

13. EXHIBITS

13.1. The following Exhibits are attached to and made a part of this Agreement:

- Exhibit A – Scope of Services
- Exhibit B – Compensation Schedule
- Exhibit C – Insurance

If there is an express conflict between the provisions of this Agreement and any Exhibit hereto, the terms of this Agreement shall take precedence over the conflicting provisions of the Exhibit.

Owner and Garver, by signing this Agreement, acknowledges that they have independently assured themselves and confirms that they individually have examined all Exhibits, and agrees that all of the aforesaid Exhibits shall be considered a part of this Agreement and agrees to be bound to the terms, provisions, and other requirements thereof, unless specifically excluded.

Acceptance of this proposed Agreement is indicated by an authorized agent of the Owner signing in the space provided below. Please return one signed original of this Agreement to Garver for our records.

[Signatures follow]



IN WITNESS WHEREOF, Owner and Garver have executed this Agreement effective as of the date last written below.

CITY OF MOORE, OKLAHOMA

GARVER, LLC

By: _____
Signature

By: _____
Signature

Name: _____
Printed Name

Name: _____
Printed Name

Title: _____

Title: _____

Date: _____

Date: _____

Attest: _____

Attest: _____



EXHIBIT A (SCOPE OF SERVICES)

Garver shall provide the following Services:

1. Conceptual Design

Upon obtaining written Notice to Proceed from the owner, Garver will begin Conceptual Design. During the conceptual design phase of the project, Garver will contract with a survey company to provide a survey of the project area. Garver will also contract with a geotechnical company to investigate the existing roadway section conditions.

The conceptual plan sheets will include:

- Title Sheet
- Pay Items
- Typical Sections
- Plan-and-Profile sheets consisting of survey data along with the following conceptual improvements:
 - Geometric roadway layout
 - Roadway widening/reconstruction areas
 - Sidewalks/trail on the east side
 - Drainage structures
 - Public sanitary sewer relocations as needed
- Special details as needed for discussion

The plans will be developed in accordance with ODOT drafting standards. The plan and profile sheets will be half-size (11"x17") and set to a 1"=30' plan scale.

2. Preliminary Design

Upon obtaining written approval from the Owner on the Conceptual Design, Garver will begin Preliminary Design. During the preliminary design phase of the project, Garver will prepare preliminary construction plans in accordance with ODOT and City of Moore specifications. The improvements within the project section are further described below:

- a. Widening of Eastern Avenue from NE 12th Street to NE 27th Street to a 5-lane typical section, including drainage improvements to meet current criteria.
- b. Installation of a 10-ft wide concrete trail along the eastern side of the roadway from NE 12th Street to NE 27th Street.
- c. Installation of a 6-ft wide sidewalk along the western side of the roadway from NE 12th Street to NE 27th Street as needed. Unless removed due to the roadway construction, the existing portions of the sidewalk will be retained and the gaps within the corridor filled for a continuous pedestrian path.
- d. Extension of the RCB between NE 18th Street and NE 19th Street to allow for the roadway widening and trail and sidewalk installation.
- e. Improvements will include ADA ramp replacements. Traffic signals will be replaced for the roadway widening and the traffic signals for the entire intersection will be upgraded to activation by Radar Detection.
- f. Garver will perform Subsurface Utility Engineering (SUE) Quality Level C (QL-C). This level of SUE will involve surveying visible utility facilities and correlating this information with existing utility records when available.
- g. Provide relocation plans for conflicting City of Moore sanitary sewers (city will relocate conflicting water mains as needed).



- h. Landscaping Improvements including street trees where allowable due to existing right-of-way and utilities constraints, brick pavers, and decorative bollards.
- i. Right-of-way & easement acquisition documents to be prepared for the improvements.

The Preliminary Design phase submittal for the project limits detailed above will include improvements of roadway, signalized intersections, drainage, public utility relocations and trail/sidewalk to include the following sheets:

- Title Sheet
- Typical Sections
- Construction Details
- Summary of Pay Items
- Construction Notes
- Roadway Summaries
- Drainage Summaries
- Drainage Area Maps
- Plan and Profile Sheets
- Survey Data Sheets
- Sanitary Sewer Relocation Sheets
- Trail/Sidewalk Details
- Traffic Signing
- Pavement Markings
- Temporary Traffic Control
- Audible Pedestrian Signal
- Phasing Diagram
- Wiring Diagram
- Cross Sections

The preliminary design will represent approximately 60 percent of final construction contract plans and include an opinion of probable costs. This submittal will not include technical specifications or “front end” contract documents. Garver will incorporate comments from the Owner on the Preliminary Design in the Final Design. Garver will proceed with Final Design after the Preliminary Design is approved by the Owner in writing.

2.1. Public Meeting

Garver will prepare exhibits and attend one (1) public meeting at a location determined by the Owner to present the preliminary design for each of the project phases. Comments will be recorded, and updates will be made to the plans at the discretion of the Owner based on public input.

3. Final Design

Once Garver receives written approval from the Owner on Preliminary Design, Garver will begin Final Design. During the final design phase of the project, Garver will prepare construction plans and specifications for the project.

The plans will include the following:

- Title Sheet
- Typical Sections
- Construction Details
- Summary of Pay Quantities and Construction Notes
- Roadway Summaries
- Drainage Summaries



- Drainage Area Maps
- Stormwater Pollution Prevention Plan
- Erosion Control
- Removals
- Plan and Profile Sheets
- Sanitary Sewer Relocation Sheets
- Sidewalk/Trail Details
- Storm Sewer Profiles
- Intersection Details
- Joint Layout Plan
- Structural Details
- Survey Data Sheets
- Traffic Signal Plans (one intersection)
- Phasing/Wiring Diagrams
- Traffic Signing Plans
- Sequence of Construction Details
- Temporary Traffic Control Plans
- Cross Sections

Final construction plans will be prepared for the RCB extension and repairs. A standard end section and apron is anticipated on either side of the roadway.

The final design will include special provisions and opinion of probable construction cost. Garver will also make any needed plan changes as a result of special easement acquisition considerations and prepare the construction documents as required to advertise for bids.

4. Bidding Services

During the bidding phase of the project, Garver will provide the following:

- A. Prepare and submit Advertisement for Bids to newspaper(s) for publication as directed by the Owner. Owner will pay advertising costs outside of this contract.
- B. Dispense construction contract documents to prospective bidders (at the approximate cost of reproduction and handling).
- C. Support the contract documents by preparing addenda as appropriate.
- D. Participate in a pre-bid meeting.
- E. Attend the bid opening.
- F. Prepare bid tabulation.
- G. Evaluate bids and recommend award.

5. Construction Phase Services

During the construction phase of work, Garver will accomplish the following:

- A. Issue a Notice to Proceed letter to the Contractor and attend preconstruction meeting.
- B. Attend three (3) progress/coordination meetings with the Owner/Contractor and provide the Owner brief reports of each visit.
- C. Evaluate and respond to construction material submittals and shop drawings. Corrections or comments made by Garver on the shop drawings during this review will not relieve Contractor from compliance with requirements of the drawings and specifications. The check will only be for review of general conformance with the design concept of the project and general compliance with the information given in the contract documents. The Contractor will be responsible for confirming and correlating all quantities and dimensions, selecting fabrication processes and techniques of construction, coordinating his work with that of all other trades, and performing his work in a safe



and satisfactory manner. Garver's review shall not constitute approval of safety precautions or constitute approval of construction means, methods, techniques, sequences, procedures, or assembly of various components. When certification of performance characteristics of materials, systems or equipment is required by the Contract Documents, either directly or implied for a complete and workable system, Garver shall be entitled to rely upon such submittal or implied certification to establish that the materials, systems or equipment will meet the performance criteria required by the Contract Documents.

- D. Issue instructions to the Contractor on behalf of the Owner and issue necessary clarifications (respond to RFIs) regarding the construction contract documents.
- E. Prepare and furnish record drawings to the Owner upon receipt of working drawings from Owner and/or Contractor.
- F. When authorized by the Owner, prepare change orders for changes in the work from that originally provided for in the construction contract documents. If redesign or substantial engineering or surveying is required in the preparation of these change order documents, the Owner will pay Garver an additional fee to be agreed upon by the Owner and Garver.
- G. Participate in final project inspection, prepare punch list, review final project closing documents, and submit final pay request.

6. Project Deliverables

The following will be submitted to the Owner, or others as indicated, by Garver:

- H. Five (5) hard copies of the Conceptual Plans.
- I. Three (3) hard copies of the Preliminary Design with opinion of probable construction cost.
- J. PDF copies of the Preliminary Plans to each potentially affected utility company for all project phases.
- K. Three (3) hard copies of the Final Design with opinion of probable construction cost.
- L. PDF copies of the Final Plans and Specifications to the Contractor.
- M. Three (3) hard copies of the right-of-way and/or easement acquisition documents.
- N. PDF copies of approved shop drawings/submittals from the Contractor.
- O. One (1) hard copy set of Record Drawings.
- P. Electronic files as requested.

7. Schedule

Garver shall begin design work under this Amendment within ten (10) days of a Notice to Proceed and shall complete the work in accordance with the schedule below:

Phase Description	Calendar Days
Conceptual Design	90 days from NTP
Preliminary Design (60%)	75 days from Approval of Conceptual Design
Final Design (100%)	60 days from Approval of Preliminary Design

8. Additional Services

In addition to those obligations set forth in the Agreement, Owner shall:

- 8.1.1 Give thorough consideration to all documents and other information presented by Garver and informing Garver of all decisions within a reasonable time so as not to delay the Services.
- 8.1.2 Make provision for the Personnel of Garver to enter public and private lands as required for Garver to perform necessary preliminary surveys and other investigations required under the applicable Work Order.
- 8.1.3 Obtain the necessary lands, easements and right-of-way for the construction of the work. All costs associated with securing the necessary land interests, including property acquisition and/or easement document preparation, surveys, appraisals, and abstract



work, shall be borne by the Owner outside of this Agreement, except as otherwise described in the Services under Section 2.1.

- 8.1.4 Furnish Garver such plans and records of construction and operation of existing facilities, available aerial photography, reports, surveys, or copies of the same, related to or bearing on the proposed work as may be in the possession of Owner. Such documents or data will be returned upon completion of the Services or at the request of Owner.
- 8.1.5 Furnish Garver a current boundary survey with easements of record plotted for the project property.
- 8.1.6 Pay all plan review and advertising costs in connection with the project.
- 8.1.7 Provide legal, accounting, and insurance counseling services necessary for the project and such auditing services as Owner may require.
- 8.1.8 Furnish permits, permit fees, and approvals from all governmental authorities having jurisdiction over the project and others as may be necessary for completion of the project.
- 8.1.9 Furnishing Garver a current geotechnical report for the proposed site of construction. Garver will coordinate with the geotechnical consultant, Owner has contracted with, on Owner's behalf for the project specific requested information.



**EXHIBIT B
(COMPENSATION SCHEDULE)**

<u>WORK DESCRIPTION</u>	<u>FEE AMOUNT</u>	<u>FEE TYPE</u>
Task 1 – Topographic Survey	\$40,964.00	LUMP SUM
Task 2 – Geotechnical Engineering	\$24,778.00	LUMP SUM
Task 3 – Subsurface Utility	\$36,128.00	LUMP SUM
Task 4 – Conceptual Design	\$44,148.00	LUMP SUM
Task 5 – Preliminary Design (60%)	\$170,097.00	LUMP SUM
Task 6 – Final Design (100%)	\$93,212.00	LUMP SUM
Task 7 – Bidding Services	\$10,329.00	LUMP SUM
Task 8 – Construction Phase Services	\$34,268.00	LUMP SUM
TOTAL FEE	\$453,924.00	

The lump sum amount to be paid under this Agreement is \$453,924. For informational purposes, a breakdown of Garver’s estimated costs is included in this Exhibit B with approximate current hourly rates for each employee classification.

The Owner will pay Garver for Service rendered at the agreed upon rates for each classification of Garver’s personnel (may include contract staff classified at Garver’s discretion) plus reimbursable expenses including but not limited to printing, courier service, reproduction, and travel. The total amount paid to Garver under this Agreement is estimated to be \$453,924. The actual total fee may exceed this estimate. For informational purposes, a breakdown of Garver’s estimated cost is included in this Exhibit B with approximate current hourly rates for each employee classification. The agreed upon rates will be increased annually with the first increase effective on or about July 1, 2024. Notwithstanding the foregoing, Garver shall be entitled, in its sole discretion, to substitute a more qualified person (e.g., C-4) with a less qualified person (e.g., C-1); provided however, in such event Garver shall only be entitled to payment at the lesser rate.

Expenses other than salary costs that are directly attributable to performance of our Services will be billed as follows:

1. Direct cost for travel, long distance and wireless communications, outside reproduction and presentation material preparation, and mail/courier expenses.
2. Direct cost-plus ten percent (10%) for subcontract/subconsultant fees.
3. Charges similar to commercial rates for reports, plan sheets, presentation materials, etc.

Additional Services (Extra Work). For services not described or included in Section 2, but requested by the Owner in writing or otherwise permitted under Section 4, the Owner will pay Garver as expressly set forth in the applicable Amendment, or in the event the Amendment is silent, for the additional time spent on the Project, at the agreed upon rates for each classification of Garver’s personnel (may include contract staff classified at Garver’s discretion) plus reimbursable expenses including but not limited to printing, courier service, reproduction, and travel. The agreed upon rates will be increased annually with the first increase effective on or about [month day, year].

Garver shall provide Owner notice when Garver is within ten percent (10%) of the not-to-exceed amount. In which event, Owner may direct Garver to proceed with the Services up to the not-to-exceed budgetary threshold before ceasing performance of the Services or increase the not-to-exceed amount with notice to Garver. Underruns in any phase may be used to offset overruns in another phase as long as the overall Agreement amount is not exceeded. In no event shall the not-to-exceed amount be interpreted as a guarantee the Services can be performed for the not-to-exceed budgetary threshold.



Exhibit B
City of Moore, Oklahoma
Eastern Ave. Widening from 12th St. to 27th St.
Garver Hourly Rate Schedule: July 2023 - June 2024

Classification	Rates	Classification	Rates
Engineers / Architects		Resource Specialists	
E-1	\$ 130.00	RS-1	\$ 104.00
E-2	\$ 144.00	RS-2	\$ 137.00
E-3	\$ 174.00	RS-3	\$ 194.00
E-4	\$ 203.00	RS-4	\$ 268.00
E-5	\$ 247.00	RS-5	\$ 335.00
E-6	\$ 304.00	RS-6	\$ 411.00
E-7	\$ 422.00	RS-7	\$ 460.00
Planners		Environmental Specialists	
P-1	\$ 157.00	ES-1	\$ 104.00
P-2	\$ 196.00	ES-2	\$ 131.00
P-3	\$ 244.00	ES-3	\$ 168.00
P-4	\$ 273.00	ES-4	\$ 198.00
P-5	\$ 308.00	ES-5	\$ 248.00
		ES-6	\$ 318.00
		ES-7	\$ 398.00
		ES-8	\$ 450.00
Designers		Project Controls	
D-1	\$ 118.00	PC-1	\$ 106.00
D-2	\$ 135.00	PC-2	\$ 140.00
D-3	\$ 161.00	PC-3	\$ 178.00
D-4	\$ 193.00	PC-4	\$ 229.00
		PC-5	\$ 280.00
		PC-6	\$ 361.00
		PC-7	\$ 454.00
Technicians		Administration / Management	
T-1	\$ 95.00	AM-1	\$ 75.00
T-2	\$ 114.00	AM-2	\$ 96.00
T-3	\$ 139.00	AM-3	\$ 134.00
T-4	\$ 180.00	AM-4	\$ 171.00
		AM-5	\$ 209.00
		AM-6	\$ 272.00
		AM-7	\$ 320.00
		M-1	\$ 510.00
Surveyors			
S-1	\$ 58.00		
S-2	\$ 77.00		
S-3	\$ 103.00		
S-4	\$ 148.00		
S-5	\$ 187.00		
S-6	\$ 218.00		
2-Man Crew (Survey)	\$ 225.00		
3-Man Crew (Survey)	\$ 282.00		
2-Man Crew (GPS Survey)	\$ 245.00		
3-Man Crew (GPS Survey)	\$ 302.00		
Construction Observation			
C-1	\$ 112.00		
C-2	\$ 140.00		
C-3	\$ 171.00		
C-4	\$ 221.00		
C-5	\$ 259.00		



**EXHIBIT C
(INSURANCE)**

Pursuant to Section 7.1 of the Agreement, Garver shall maintain the following schedule of insurance until completion of the Services:

Worker's Compensation	Statutory Limit
Automobile Liability Combined Single Limit (Bodily Injury and Property Damage)	\$500,000
General Liability Each Occurrence	\$1,000,000
Aggregate	\$2,000,000
Professional Liability Each Claim Made	\$1,000,000
Annual Aggregate	\$2,000,000
Excess of Umbrella Liability Per Occurrence	\$1,000,000
General Aggregate	\$1,000,000

**STANDARD
FORM OF AGREEMENT
BETWEEN CITY OF MOORE
AND ENGINEER
FOR
PROFESSIONAL SERVICES**



Issued By
CITY MANAGEMENT DEPARTMENT
In conjunction with the
CITY'S LEGAL DEPARTMENT

CITY HALL, 301 N. Broadway
Moore, Oklahoma

**AGREEMENT
BETWEEN
CITY OF MOORE AND ENGINEER
FOR
PROFESSIONAL SERVICES**

FOR

**NE 27th STREET RECONSTRUCTION PROJECT
(I-35 SERVICE ROAD TO N. EASTERN AVE)**

**CITY OF MOORE
CLEVELAND COUNTY, OKLAHOMA**

DATE: December 18, 2023

PREPARED BY:
**City of Moore
City Management Department**

TABLE OF CONTENTS

Page No.

1.	SECTION 1 - BASIC SERVICES OF ENGINEER	4
1.1.	General.....	4
1.2.	Preliminary Design Phase.....	11
1.3.	Final Design Phase.....	11
1.4.	Advertising and Bidding Phase.....	12
1.5.	Construction Phase.....	13
2.	SECTION 2 - OWNER`S RESPONSIBILITIES	14
3.	SECTION 3 - PERIOD OF SERVICES.....	15
4.	SECTION 4 - PAYMENTS TO ENGINEER	16
4.1.	Methods of Payment for Services of Engineer.	16
4.2.	Times of Payment.	17
	EXHIBIT "A" SCOPE OF SERVICES	20
	EXHIBIT "B" ...FEE QUOTATION.....	29

**AGREEMENT
BETWEEN
CITY OF MOORE AND ENGINEER
FOR
PROFESSIONAL SERVICES**

THIS IS AN AGREEMENT made as of the 18th day of December in the year 2023 by and between the City of Moore, A Municipal Corporation in the State of Oklahoma (hereinafter called OWNER), and Olsson Inc. (hereinafter called ENGINEER). OWNER intends to employ a professional ENGINEER to provide professional engineering services and prepare contract documents for the NE 27th Street Reconstruction Project (I-35 Service Road to N. Eastern Ave), hereinafter referred to as the PROJECT.

The OWNER and ENGINEER in consideration of their mutual covenants herein agree in respect of the performance of professional engineering services by ENGINEER and the payment for those services by OWNER, as set forth below.

ENGINEER shall serve as OWNER's professional engineering representative in those phases of the Project to which this Agreement applies and will give consideration and advice to OWNER during the performance of his services.

1. SECTION 1 - BASIC SERVICES OF ENGINEER

1.1. General

- 1.1.1. ENGINEER shall perform professional services as hereinafter stated which include normal civil and surveying activities as required.
- 1.1.2. Laws, Licenses and Permits. The ENGINEER shall comply with all Federal, State and local laws, regulations and ordinances applicable to the contract.
- 1.1.3. Worker's Compensation Law. The ENGINEER shall comply with the Oklahoma Worker's Compensation Law and file a copy of his Worker's Compensation Insurance Policy, or, if a self-insurer, a copy

of the Industrial Commission's Order of Authorization with the OWNER.

- 1.1.4. ENGINEER's Liability. The ENGINEER shall assume responsibility for and save the OWNER harmless from claims for injury to, or death of persons, or damage to property arising from the ENGINEER's negligent acts, errors, or omissions, or those of their agents or employees, arising out of performance of the work.
- 1.1.5. Non-collusion. The ENGINEER warrants that they have not employed or retained any company or person, other than a bona fide employee working solely for the ENGINEER to solicit or secure this contract, and that they have not paid or agreed to pay any company, political group, or person, other than a bona fide employee working solely for the ENGINEER, any fee, commission, percentage, brokerage fee, gifts, or any other consideration, contingent upon or resulting from the award of this contract. For breach of violation of this warranty, the OWNER shall have the right to annul this contract without liability, or at its discretion to deduct from the contract price or consideration, or otherwise recover the full amount of such price or consideration, or otherwise recover the full amount of such fee, commission, percentage, brokerage fee, gift, or contingent fee.
- 1.1.6. Services Furnished, Performed and Submitted. The ENGINEER shall furnish all engineering services, labor and equipment as may be required in the performance of the contract, except as otherwise provided herein, and all work performed and submitted under the contract shall be done in a manner acceptable to the OWNER, and the ENGINEER shall sign the plans submitted to the OWNER and affix his Oklahoma seal thereto as proof that he is a Registered Professional Engineer in the State of Oklahoma.
- 1.1.7. Coordination of Work. The ENGINEER will coordinate their engineering work with other Engineers, if any, performing the immediately adjoining engineering work, and shall furnish and share survey and plan data in such a manner as will facilitate and expedite the completion of contracts in adjacent engineering work.
- 1.1.8. Maintaining All Records. The ENGINEER shall maintain all books, documents, papers, accounting records, and other evidence pertaining to cost incurred in the performance of this contract and to make such materials available to their respective offices at all reasonable times, during the contract period and for five (5) years from the date of final payment under the contract, for inspection by authorized representatives of the OWNER. Copies thereof shall be furnished if requested and the OWNER shall pay a reasonable cost of reproduction.

- 1.1.9. Responsibility for Accuracy. The ENGINEER will be held responsible for accuracy of engineering details and quantities of work to be performed. Plans received for review by the OWNER shall be accompanied by a written statement that a prior detailed check has been made. Frequent occurrence of irregularities in engineering details or quantities will be basis for withholding future engineering contracts from said ENGINEER or termination of this agreement upon failure to remedy the problem within a reasonable period of time. The ENGINEER shall furnish design data with computations for all improvements involved in this contract. The ENGINEER will be held responsible for any mistakes or omissions in the work of the ENGINEER, which appear during the final review by the OWNER or during construction and will be required to do any work necessary to correct the mistakes or omissions in their work, without additional compensation.
- 1.1.10. Major Revisions. For any major revisions ordered in writing by the OWNER in the PROJECT after the final survey has been completed, a supplemental agreement for additional payment shall be entered into between the parties hereto. For any major revision in the character or scope of the work in design ordered in writing by the OWNER after performance of a substantial amount of work on the plans, a Supplemental Agreement will be negotiated on the basis of all costs related to the salaries of employees for the time directly chargeable to the agreement, the salaries of principals for the time they are productively engaged in work necessary to fulfill the term of the agreement, direct non-salary cost incurred in fulfilling the terms of the agreement and the ENGINEER's overhead or indirect costs to the extent they are properly allowable to the agreement plus a lump sum for profit.
- 1.1.11. Right to Terminate. The OWNER reserves the right to terminate the contract at any time, and if this project should be abandoned, or the processing of same indefinitely postponed, or contract terminated for any other reasons, the ENGINEER shall be paid the reasonable value by the OWNER for the data delivered or ready for delivery upon receipt thereof based upon availability of funds for this work, and such determination by the OWNER shall be conclusive and binding. Prior to the award of the contract to the ENGINEER, the OWNER shall confirm to the ENGINEER and provide satisfactory proof that funds for the amount of the contract have been authorized, allocated, and reserved for payment of the ENGINEER's fee.
- 1.1.12. Right to Delete. The OWNER reserves the right to delete any portion of the contract at any time, and if such is done the total engineering fee shall be reduced in the same ratio as the estimated cost of the work deleted compares to the estimated cost of the work as originally planned, or when appropriate, the engineering fee shall be recomputed

for the reduced scope of work in the same manner used for determining the original contract fee, provided that if work has already been accomplished on that portion of the contract to be deleted the ENGINEER shall be paid for the deleted portion on the basis of the estimated percentage of completion of such portion.

- 1.1.13. Non-Discrimination. The ENGINEER will comply with all the requirements pertaining to the Section 3 Clause of the 1968 Housing and Urban Development Act (Affirmative Action Plan).
- 1.1.14. Assignments and Subleases. ENGINEER shall not assign, sublease, subcontract, transfer or convey any interest in this Agreement without the express and prior written consent of the OWNER. The ENGINEER's interest hereunder shall not be assignable in bankruptcy or by operation of law. In the event a transfer is approved by OWNER, any document by which an interest is granted shall indicate that the person acquiring the interest takes subject to the terms of this Agreement. OWNER may prescribe any conditions to such an assignment or transfer.
- 1.1.15. Waiver. No waiver of default by OWNER or ENGINEER of any terms, covenants or conditions herein to be performed, kept or observed by ENGINEER or OWNER shall be construed to be or act as a waiver of any subsequent default of any terms, covenants or conditions herein contained.
- 1.1.16. Merger. It is mutually understood and agreed by the parties hereto that this Agreement contains all the covenants, agreements, stipulations, and provisions agreed upon by said parties, and no agent or employee of either party to this Agreement has any authority to alter or change the terms hereof, except as provided herein, and neither party is or shall be bound by any statement or representation not in conformity herewith.

If in the event that any portion or portions of this Agreement are adjudged unlawful by a court of competent jurisdiction, the judgment of such court shall not affect the validity of the remaining portions hereof, which shall be and remain in full force and effect during the term of this Agreement.

- 1.1.17. Enforceability; Choice of Law; Choice of Forum. Litigation arising out of or connected with this Agreement may be instituted and maintained in the courts of the state of Oklahoma only, and the parties consent to jurisdiction over their person and over the subject matter of any such litigation.
- 1.1.18. Key Personnel. The ENGINEER shall have designated certain key personnel to be assigned specifically to the performance of this work (such as project manager, lead designer, operations specialist, etc.).

- 1.1.19. At the time of Agreement ratification, the OWNER shall have the right to specify those project key personnel for whom the ENGINEER shall not be allowed to substitute other personnel without prior written permission of the OWNER.
- 1.1.20. Detailed Scope of Services. A detailed scope of services is attached as Exhibit "A", which is hereby incorporated into this contract.
- 1.1.21. Insurance. The ENGINEER shall procure and maintain during the life of this agreement insurance of the types of minimum amounts as follows:

Worker's Compensation in full compliance with statutory requirements of Federal and State of Oklahoma law and Employer's Liability coverage in the amount of \$500,000.

Commercial General Liability and Bodily Injury:

Bodily Injury	\$ <u>125,000</u> each occurrence
Property Damage	\$ <u>100,000</u> each occurrence
Combined Single Limit	<u>\$1,000,000</u> aggregate

Comprehensive Automobile:

Liability, Bodily Injury	\$ <u>125,000</u> each occurrence
Property Damage	\$ <u>100,000</u> each occurrence
Combined Single Limit	<u>\$1,000,000</u> aggregate

<u>Professional Liability:</u>	\$ <u>500,000</u> per claim
<u>(Errors and Omissions):</u>	<u>\$1,000,000</u> aggregate

Certificate evidencing such insurance shall be furnished to the OWNER and shall contain the following statement: "The insurance evidenced by this certificate will not be canceled or altered except after ten (10) calendar days from receipt by the OWNER of written notice thereof." Should the insurance outlined above be canceled for any reason, and the Engineer fails to procure additional insurance, the OWNER shall have the right to purchase equivalent insurance coverage and charge the cost of that insurance against any amounts due the ENGINEER under the terms of this Agreement.

Said insurance shall be written by a company or companies licensed to do business in the State of Oklahoma and satisfactory to the OWNER.

1.1.22. Drug-Free Workplace

1.1.22.1. Definitions. As used in this clause, “controlled Substance” means a controlled substance in schedules I through V of section 202 of the Controlled Substance Act (21 U.S.C. 812) and as further defined in regulation 21 CFR 1308.11-1308.15. “Conviction” means a finding of guilt (including a plea of nolo contendere) or imposition of sentence, or both, by any judicial body charged with the responsibility to determine violations of the Federal or State criminal drug statutes. “Criminal drug statute” means a Federal or non-Federal criminal statute involving manufacture, distribution, dispensing, possession or use of any controlled substance.

“Drug-free workplace” means the site(s) for the performance of work done by the Contractor in connection with a specific contract at which employees of the contractor are prohibited from engaging in the unlawful manufacture, distribution, dispensing, possession, or use of a controlled substance.

“Employee” means an employee of a Contractor directly engaged in the performance of work under a government contract.

“Directly engaged” is defined to include all direct cost employees and any other employee who has other than a minimal impact or involvement in contract performance.

1.1.22.2. The ENGINEER, if other than an individual, shall--within thirty (30) calendar days after award (unless a longer period is agreed to in writing) for contracts of thirty (30) calendar days or more performance duration; or as soon as possible for contracts of less than thirty (30) calendar days of performance duration--

1. Publish a statement notifying its employees that the unlawful manufacture, distribution, dispensing, possession, or use of a controlled substance is prohibited in the ENGINEER’s workplace and specifying the actions that will be taken against employees for violation of such prohibition;
2. Establish an ongoing drug-free awareness program to inform such employees about –
 - (i) The dangers of drug abuse in the workplace
 - (ii) The ENGINEER’s policy of maintaining a drug-free workplace
 - (iii) Any available drug counseling, rehabilitation, and employee assistance programs; and
 - (iv) The penalties that may be imposed upon employees for drug abuse violations occurring in the workplace.

3. Provide all employees engaged in performance of the contract with a copy of the statement required by subparagraph 1.1.21.2.1. of this clause:
4. Notify such employees in writing of the statement required by subparagraph 1.1.21.2.1. of this clause, that as a condition of continued employment of this contract, the employee will
 - (i) Abide by the terms of the statement; and
 - (ii) Notify the employer in writing of the employee's conviction under a criminal drug statute for a violation occurring in the workplace no later than five (5) days after such conviction.
5. Notify the contracting officer in writing within ten (10) days after receiving notice under subdivision 1.1.21.2.4. (ii) of this clause from an employee or otherwise receiving actual notice of such conviction. The notice shall include the position title of the employee.
6. Within thirty (30) calendar days after receiving notice under subdivision 1.1.21.2.4. (ii) of this clause of a conviction, take one (1) of the following actions with respect to any employee who is convicted of a drug abuse violation occurring in the workplace.
 - (i) Take appropriate personnel action against such employee, up to and including termination; or
 - (ii) Require such employee to satisfactorily participate in a drug abuse assistance or rehabilitation program approved for such purposes by a Federal, State, or local health, law enforcement, or other appropriate agency.
7. Make a good faith effort to maintain a drug-free workplace through implementation of subparagraphs 1.1.21.2.1. through 1.1.21.2.6. of this clause.

1.1.22.3. The ENGINEER, if an individual, agrees by award of the contract or acceptance of a purchase order, not to engage in the unlawful manufacture, distribution, dispensing, possession, or use of a controlled substance in the performance of this contract.

1.1.22.4. In addition to other remedies available to the Owner, the ENGINEER's failure to comply with the requirements of paragraphs 1.1.21.2. and 1.1.21.3. of this clause may, pursuant to FAR 23.506, render the ENGINEER subject to suspension of contract payments, termination of the contract for default, and suspension or debarment.

1.2. Preliminary Design Phase.

After written authorization to proceed with the Preliminary Design Phase, ENGINEER shall:

- 1.2.1. In consultation with the OWNER and on the basis of the detailed scope of services (Exhibit "A"), prepare preliminary design documents consisting of final design criteria, preliminary drawings and outline specifications.
- 1.2.2. Based on the preliminary design plans, submit an opinion of probable cost for the project including construction cost, contingencies, compensation for all professionals and consultant services.
- 1.2.3. Furnish three (3) copies of the above preliminary design plans and present and review them in person with the OWNER.

1.3. Final Design Phase.

After written authorization to proceed with the Final Design Phase, ENGINEER shall:

- 1.3.1. On the basis of the accepted preliminary design documents, incorporate contract documents, final plans, quantities, construction estimates and specifications to show the character and scope of the work to be performed by Contractors on the PROJECT.
- 1.3.2. Furnish to OWNER such documents and design data as may be required for, and assist in the preparation of, the required documents so that OWNER may obtain approvals of such governmental authorities as have jurisdiction over design criteria applicable to the PROJECT and assist in obtaining such approvals by participating in submissions to and negotiations with appropriate authorities.
- 1.3.3. Advise OWNER of any adjustments to his latest opinion of probable project cost caused by changes in design requirements or construction costs and furnish a revised opinion of probable project cost based on the drawings and specifications.
- 1.3.4. Prepare bid forms, notice to bidders, instruction to bidders, general conditions and supplementary conditions and assist in the preparation of other related documents.
- 1.3.5. Furnish three (3) copies of the above documents and present and review them in person with OWNER.
- 1.3.6. Furnish five (5) copies of the approved final design documents to the OWNER.
- 1.3.7. Assist OWNER in acquisition of the required local, State and Federal government permits (Health Department, ODOT, etc.) and private permits (railroad, utility, etc.). The ENGINEER shall at no additional

cost to OWNER provide sets of construction plans and specifications as may be necessary for application of such permits.

1.4. Advertising and Bidding Phase.

After written authorization to proceed with the Advertising and Bidding Phase, ENGINEER shall:

- 1.4.1. Assist OWNER in obtaining bids or negotiating proposals for the construction contract. The ENGINEER shall supply prospective bidders with the project plans and contract documents for a fee to be retained by the ENGINEER to cover the costs for reproduction, etc.; the amount of the fee to be agreed upon by the ENGINEER and the OWNER. The ENGINEER shall record the name, address and telephone number of each prospective bidder obtaining the contract documents.
- 1.4.2. Attend the Pre-Bid Conference to assist the OWNER in answering any questions pertaining to the project which the prospective bidders may have.
- 1.4.3. Consult with and advise OWNER as to the acceptability of subcontractors and other persons or organizations proposed by the contractor(s) (hereinafter called "Contractor(s)") for those portions of the work as to which such acceptability is required by the contract documents.
- 1.4.4. Consult with and advise OWNER as to the acceptability of substitute materials and equipment proposed by Contractor(s) when substitution is permitted by the contract documents.
- 1.4.5. Assist OWNER in evaluating bids or proposals and in assembling and awarding contracts.

1.5. Construction Phase.

During the Construction Phase, the ENGINEER shall:

- 1.5.1. Consult with and advise OWNER and act as his representative. All of OWNER's instructions to Contractor(s) will be issued through the Assistant City Manager or his designated representative.
- 1.5.2. Make monthly visits to the site to observe as an experienced and qualified design professional, the progress and quality of the executed work and to determine in general if the work is proceeding in accordance with the contract document; they shall not be required to make exhaustive or continuous on-site inspections to check the quality

or quantity of work; they shall not be responsible for the means, methods, techniques, sequences or procedures of construction selected by Contractor(s) or the safety precautions and programs incident to the work of Contractor(s). Their efforts will be directed toward providing assurance for OWNER that the completed PROJECT will conform to the contract documents; but they shall not be responsible for the failure of Contractor(s) to perform construction work in accordance with the contract documents. During such visits and on the basis of their on-site observances, they shall provide OWNER written reports on the progress, performance and quality of the work. The ENGINEER shall endeavor to guard OWNER against defects and deficiencies in the work of Contractor(s) and may recommend to OWNER the disapproval or rejection of work as failing to conform to the contract documents.

- 1.5.3. Review and approve shop drawings and samples, the results of tests and inspections and other data which any Contractor is required to submit, but only for conformance with the design concept of the PROJECT and compliance with the information given in the contract documents; determine the acceptability of substitute materials and equipment proposed by Contractor(s); and receive and review (for general content as required by the specifications) maintenance and operating instructions, schedules, guarantees, bonds and certificates of inspection which are to be assembled by Contractor(s) in accordance with the contract documents.
- 1.5.4. Conduct, when notified by OWNER, a final inspection of the project and provide the OWNER a written report indicating the ENGINEER's opinion as to the conformance of the completed work to the contract documents, quality of the work performed, performance of the Contractor(s) and a list of any deficient items.
- 1.5.5. Perform such additional services as may be set forth under this phase of the work as shown in Exhibit "A".

2. SECTION 2 - OWNER'S RESPONSIBILITIES

OWNER shall:

- 2.1. Provide full information as to his requirements for the project.
- 2.2. Assist the ENGINEER by placing at their disposal all available information pertinent to the project including previous reports and any other data relative to design and construction of the PROJECT.
- 2.3. Examine all studies, reports, sketches, estimates, specifications, drawings, proposals, and other documents presented by the ENGINEER and render in writing decisions

pertaining within a reasonable time so as not to delay the services of the ENGINEER.

- 2.4. Pay all advertising costs incident to obtaining bids or proposals from Contractor(s).
- 2.5. Return to the ENGINEER submitted project documents for OWNER's review on which the ENGINEER has not substantially addressed previously noted provisions and comments. The ENGINEER's contract time will not be suspended for submission of project documents which do not contain substantial revisions.
- 2.6. Provide a testing firm and pay all costs for testing, as required for design of the PROJECT, unless specified otherwise.
- 2.7. Designate in writing a person to act as OWNER's representative with respect to the work to be performed under this agreement. Such person shall have complete authority to transmit instructions, receive information and interpret and define OWNER's policies and decisions with respect to materials, equipment, elements, and systems pertinent to ENGINEER's services.
- 2.8. Issue all instructions to the ENGINEER; act as interpreter of the requirements of the contract documents and judge of the performance thereunder by the parties thereto and shall make decisions on all claims of the ENGINEER relating to the execution and progress of the work and all other matters and questions related thereto.
- 2.9. In consultation with the ENGINEER, issue all instructions to Contractor(s); prepare routine change orders as required; require, if deemed appropriate, special inspection or testing of the work; act as interpreter of the requirements of the contract documents and judge of the performance thereunder by the parties thereto and shall make decisions on all claims of OWNER and Contractor(s) relating to the execution and progress of the work and all other matters and questions related thereto.
- 2.10. Have the Assistant City Manager or their designated representative, based on his on-site observations and project inspection reports, determine the amounts owing to Contractor(s).
- 2.11. Conduct an inspection to determine if the PROJECT is substantially complete and a final inspection to determine if the project has been completed in accordance with the contract documents and if each Contractor has fulfilled all of his obligations thereunder so that OWNER may approve, in writing, final payment to each Contractor.

3. SECTION 3 - PERIOD OF SERVICES

- 3.1. The provisions of 3.2. through 3.5. inclusive, and the various rates of compensation for ENGINEER's services provided for elsewhere in this agreement have been agreed to in anticipation of the orderly and continuous progress of the PROJECT through completion of the Construction Phase. The ENGINEER's obligation to

render services hereunder will extend for a period which may be reasonably required for the design, award of contracts and construction of the PROJECT.

3.2. The PROJECT scope of services shall be completed by the schedule set forth in Exhibit "A" Section H following authorization to proceed. This schedule assumes authorization to proceed is received in December 2023. Specific time frames and requirements for completion of various items within the basic scope of services shall be completed as specified in the following paragraphs:

3.2.1. The services called for in the Surveying and Preliminary Design Phase shall be completed by February 1, 2024, in accordance with Exhibit "A" Section H.

3.2.2. After acceptance by OWNER of the preliminary design plans, opinion of probable project cost, indicating any specific modifications or changes desired by OWNER, and upon written authorization from OWNER, ENGINEER shall proceed with the performance of the services called for in the Final Design Phase, so as to deliver final contract documents and a revised opinion of project cost for all authorized work by February 1, 2025.

3.2.3. ENGINEER's services under the Preliminary Design Phase and Final Design Phase shall each be considered complete at the date when the submissions for that phase have been accepted and approved by the OWNER.

3.2.4. After acceptance of OWNER of the final construction plans and the ENGINEER's most recent opinion of probable project cost and upon written authorization to proceed, the ENGINEER shall proceed with performance of the services called for in the Advertising and Bidding Phase. This Phase shall terminate and the services to be rendered thereunder shall be considered complete upon award of the contract.

3.2.5. The Construction Phase will commence with the execution of the awarded construction contract for the work of the PROJECT or any part thereof and will terminate upon written approval by Assistant City Manager or their designated representative of final payment of the contract.

3.2.6. In the event that the work of the project is to be performed under more than one contract, OWNER and ENGINEER shall, prior to commencement of the Final Design Phase, develop a schedule for performance of ENGINEER's services during the Final Design and Advertising and Bidding Phases in order to sequence and coordinate properly such services as applicable to the work under such separate contracts. This schedule is to be prepared whether or not the work under such contracts is to proceed concurrently and is to be attached

as an exhibit to and made a part of this agreement and the provisions of paragraphs 3.4. and 3.5. will be modified accordingly.

- 3.3. If OWNER has requested significant modifications or changes in the PROJECT, the time of performance of ENGINEER`s services shall be adjusted appropriately.
- 3.4. If ENGINEER is delayed at any time in the progress of any phase of the project by any act or neglect of the OWNER, or by any separate contractor employed by the OWNER, or by any act or neglect of regulatory agencies, or by labor disputes, fire, unusual delay in transportation, adverse weather conditions not reasonably anticipatable, unavoidable casualties, or any causes beyond the ENGINEER's control, then the Contract completion date shall be extended by Supplemental Agreement (Amendment) for a reasonable time equaling the amount of delay.
- 3.5. Waiver in Case of Delay. In the event of delay in proceeding with the work hereunder or any portion thereof, whether such delay be caused by the OWNER or any other agency, the ENGINEER hereby agrees that he will not exert any claim against the OWNER by reason of such delay, and all such claims are hereby waived.

4. SECTION 4 - PAYMENTS TO ENGINEER

4.1. Methods of Payment for Services of Engineer.

- 4.1.1. Services as a Witness. The OWNER will pay the ENGINEER for the services of the principals and employees as witnesses at the rate of \$220.00 per hour for a principal's time and \$170.00 per hour for a senior engineer or any portion thereof plus all reimbursable expenses, except that no payment shall be made for services as a witness in any case wherein the OWNER is an adverse party, to the ENGINEER.
- 4.1.2. For services described herewith, exclusive of fees for services as witnesses, the ENGINEER will be paid the fee(s) as outlined in Exhibit "B".

4.2. Times of Payment.

- 4.2.1. ENGINEER shall submit monthly statements for services rendered. Compensation will be based on the ENGINEER`s estimate of the proportion of the total services actually completed at the time of billing and agreed upon by the Assistant City Manager or their designated representative. The OWNER shall make prompt monthly payments in response to ENGINEER`s monthly statements.
- 4.2.2. OWNER shall, upon conclusion of the Preliminary Design, Final Design, Advertising and Bidding Phase, and Construction Phase services, pay according to the Phases and Unit Quantities set forth in Exhibit "B" Basis of Compensation.

Additional cost to the OWNER caused by error or omission of items in the construction documents will not be included in final construction cost for determination of the ENGINEER's fee unless the ENGINEER is instructed by the OWNER to prepare the additional contract documents to address the error or omission.

- 4.2.3. ENGINEER shall submit to the OWNER, prior to commencement of the Advertising and Bidding Phase, Deliverables including digital files of the project in PDF format, relevant project drawings in CAD format, and specifications referenced in the final plans.
- 4.2.4. Prior to receiving final payment, the ENGINEER shall also submit to OWNER one (1) set of ½ size "As-Built Record Drawings" (hereinafter referred to "As-Builts") plans including digital files in PDF and CAD format. The "As-Built" drawings shall represent any changes that occurred during construction. The OWNER shall supply to the ENGINEER all changes that occurred during construction, in sufficient detail to allow the ENGINEER to prepare the "As-Built" drawings, unless the ENGINEER is responsible for construction management.

IN WITNESS WHEREOF, the parties hereto have executed this Agreement the day and year first above written.

On Behalf of ENGINEER:

(FOR CORPORATIONS ONLY)

OLSSON Inc.
Name of Corporation

By _____
Title _____

ATTEST:

Title _____

(AFFIX SEAL)

(FOR PARTNERSHIPS AND PROPRIETORSHIPS)

Name of Partnership or Proprietorship

By _____

Title _____

COUNTY OF CL }
STATE OF OKLAHOMA }

Before me the undersigned, a Notary Public in and for said state, on this ____ day of _____, 2023, personally appeared _____, a member of the partnership/proprietorship OLSSON Inc. to me known to be the identical person who executed the within and foregoing instrument on behalf of said partnership/proprietorship and acknowledged to me that _____ (he/she) executed the same as _____ (his/her) free and voluntary act and deed, and for the free and voluntary act and deed of said partnership/proprietorship, for the uses and purposes therein set forth.

Notary Public

My Commission Expires _____

CITY OF MOORE, OKLAHOMA
A Municipal Corporation

Glenn Lewis, MAYOR

ATTEST:

Vanessa Kemp, CITY CLERK

APPROVED as to form and legality on behalf of the City of Moore, Oklahoma,
this _____ day of _____, 2023.

Brian Miller, CITY ATTORNEY

EXHIBIT “A”

SCOPE OF SERVICES

CITY OF MOORE

**NE 27th STREET RECONSTRUCTION
(I-35 SERVICE ROAD TO N EASTERN AVE)**

PROJECT DESCRIPTION AND LOCATION

Project will be located at: NE 27th St from I-35 to N Eastern Ave

Project Description: Purpose of the project is to widen and reconstruct the existing 4-lane roadway to 5-lanes and provide intersection improvements.

SCOPE OF SERVICES

ENGINEER shall provide the following services (Scope of Services) to OWNER for the Project:

Task 1	Project Management
Task 2	Survey
Task 3	Design
Task 4	Traffic Design
Task 5	Environmental Clearance
Task 6	Geotechnical Services (Optional)
Task 7	Utility Coordination
Task 8	Utility Relocations
Task 9	Bidding Assistance / Construction Support / As-Builts

CONSTRUCTION DOCUMENTS

Quality Control reviews for all design submittals will be completed by the consulting engineer using an independent review team.

Task 1 - Project Management

ENGINEER shall have a Project Manager to oversee project.

Project management duties will include:

- Coordination with “OWNER” for plan submittals, schedules and approvals
- Maintaining and tracking of a project schedule.
- Attending owner meetings (every month anticipated) and other meetings as needed throughout the life of the project requested by the owner or other agencies.
- Provide monthly progress reports detailing the project status, schedule, and upcoming work.

- Processing of monthly invoices

Task 2 - Survey Services

Olsson shall provide the following Land Surveying services (Scope of Services) to the Client for the Project

Topographic Survey

Olsson shall perform and prepare a right-of-way and topographic survey of NE 27th St in Moore, Oklahoma. The corridor to be surveyed is approximately 6,000 feet in length with the width being 200 feet (100 feet on each side of the centerline of NE 27th St) and located along the North section line of section 11, Township 10 North, Range 3 West of the IB&M. The project site and survey limits are shown on Exhibit "A" with the scope being further defined below:

The project shall be based upon the Oklahoma State Plane Coordinate System, South Zone (NAD83) with vertical datum being referenced to NAVD88. Vertical and horizontal control shall derive from City of Moore Control Monument Network and/or static GPS observations processed through OPUS and shall be shown in grid distances and bearings. Olsson will provide three (4) project control points.

The NE 27th St right-of-way will be determined beginning 400 feet West of I35 continuing East between I35 and N Eastern Ave based on field investigation and research performed at the Cleveland County Assessor and Clerk's offices. Only right-of-way lines and the immediate property line which tie into the right-of-way shall be surveyed. This does not constitute a boundary survey on each individual property. Survey work shall be done under the direction and supervision of a Licensed Professional Land Surveyor licensed in the State of Oklahoma.

The survey shall depict topographic features including showing contours at a 1' vertical interval, physical improvements including buildings, finished floor elevations, roads, driveways, parking, fencing, general vegetation, outline of treed areas (no individual trees), and visible above ground utilities as well utility locations marked by an 811 locate request. Utility companies will be contacted through the Oklahoma One Call (811) system and utilities marked will be shown on the topography survey. Olsson will locate and detail sanitary and storm utility structures to show pipe sizes and direction.

NOTE: Utility location and mapping is for horizontal location of above ground and underground utilities only. Other than sanitary and storm inverts, utility depths will not be obtained or indicated on the survey. Survey of utilities will be based on tracing and marking by a 811 One Call utility locate and provided or available maps. By signing this contract, the client understands and acknowledges that utility mapping is not exact and it is possible that not all utility lines will be located. Olsson is not responsible for miss-marked or unmarked utilities.

Private Utility Survey

Olsson shall use a subconsultant to perform a private utility locate to locate, to the best of their abilities, utilities on site as shown on the survey limits on Exhibit "A". Other than sanitary and storm inverts, utility depths will not be obtained or indicated on the survey. The location of sanitary sewer laterals is not included in this fee as the locating methods cannot reliably locate these lines.

- Upon completion of this locate, Olsson will survey marked lines and incorporate that information into the survey drawing.
- This phase shall be done at the same time as the topographic survey in order to provide the best pricing and minimize additional trips to the project site. Should it be done at a later date, additional fees will apply.

Legal Descriptions

Olsson will write legal descriptions in support of the project. Each description will be in a metes and bounds format describing the requested tract/area of land. Each description will be accompanied by an exhibit which graphically depicts and shows the corresponding description as it relates to the property in which it is in.

- This phase assumes 20 legal descriptions will be needed for the project. Additional descriptions can be written for additional fee.

Deliverables

Olsson shall provide the following deliverables to the client:

- MicroStation DGN file of the survey.
- PDF of the final topographic survey.
- Survey data sheets will be provided in a format consistent with City of Moore requirements.

Assumptions/Exclusion

- Client responsible for coordination and site access prior to commencing survey.
- Any changes to survey scope may affect the cost and schedule of the survey. All additional work shall be approved by the client prior to commencement of that additional work.
- Only the right-of-way information as described hereon shall be shown on the survey. No other boundary information outside of what is described is included in this scope.

Task 3 – Roadway Design

The design shall be split into two (2) tasks. The Preliminary Design Task 3A, which includes the Preliminary Design Report and 30% plan submittal and the Final Design Task 3B, which includes the remaining design effort for the 60%, 90% and Final plan submittals.

Roadway

NE 27th St will be converted from a 4-lane roadway to a 5-lane roadway from I-35 to N Eastern Ave. The facility has a posted speed limit of 40 mph, which will be used as the design speed. It is anticipated that the roadway will be constructed with a concrete section with curb and gutter. 6-foot ADA compliant sidewalks will also be included along one side of the roadway and 10-foot shared use path on the other side.

Erosion Control

Erosion Control plans will be provided for permanent and temporary erosion and sediment control. Silt fencing and inlet sediment filters will be utilized to control erosion.

Street / Roadway Drainage & Localized Hydraulics

Roadway drainage will be evaluated for the roadway improvements as needed based upon standard hydraulics and hydrology analyses as necessary to accommodate the proposed improvements and prevent standing water from accumulating on the roadway.

Existing storm sewer locations and drainage areas will be analyzed and updated to ensure it meets drainage standards.

ADA / Sidewalks / Bicycle Lanes

ADA compliant sidewalks will be included along the corridor. It is anticipated that 6-foot wide sidewalks will extend along one side of the roadway and a 10-foot wide shared use path will extend along the other.

Signing and Striping / Traffic Control

The scope includes the preparation of signing and striping plans through the project extents. Plans will be developed in accordance with the latest City of Moore and ODOT standards and specifications.

The scope includes the preparation of sequencing and traffic control plans for each construction phase of the project. The design intent will be to maintain 2 lanes of traffic at all times throughout construction and to allow access to all residences and main entrances within the project limits. Temporary traffic signals will be provided at the I-35 frontage road intersections if needed. Plans will be developed in accordance with the latest City of Moore and ODOT standards and specifications.

Task 4 – Traffic Design

Traffic Study/Analysis

Intersection turning movement counts will be collected from 7:00 am to 7:00 pm at the intersections of NE 27th St at both the east and west I-35 frontage roads. Existing signal timings will be recorded and observed in the field at different peak periods (AM, noon, and PM peaks) throughout the day versus observed queue extents and delays. Any observed operational issues will be recorded. Traffic operational analyses will be

conducted on the intersections based on the peak hour traffic counts at the two intersections for current year base conditions and for a design horizon year of 2045.

Following the base conditions traffic analysis, improvements will be considered at the intersection to improve certain lane use groups. Operational analysis will be conducted for the improved scenario for current year and design horizon conditions and compared and contrasted versus the unimproved base conditions. The results of the analysis will be summarized in a traffic study memo or as a section of the Preliminary Engineering Report.

Traffic signal clearance intervals for pedestrians and vehicles will be calculated and timing recommendations provided. Time-of-day signal timing plans will be provided for the two intersections; signal operations are anticipated to be driven by a single controller and either video or radar detection.

Existing access in the vicinity of the interchange area will be assessed, and recommendations for improving access management for the area to improve overall safety a simpler driving task will be provided in the study memo.

Traffic Signal Modifications

The scope includes the preparation of traffic signal plans, a signal phasing sheet, signal wiring diagrams, and any additional details needed for the modifications to the existing traffic signals. Signal plans will cover both NE 27th St intersections at both the east and west I-35 frontage roads. The anticipation is that the existing signal poles and controller will be replaced as part of this project. Plans will be developed in accordance with the latest City of Moore and ODOT standards and specifications.

Task 5 - Environmental Clearance

Regulatory Provisions Checklist

ENGINEER's responsibility for environmental clearance shall be limited to preparing/completing ODOT's Regulatory Provisions Checklist for Non-FHWA Funded Projects. The environmental review necessary to acquire right-of-way and construct the PROJECT shall be submitted and obtained by ODOT as is the ordinary practice for ACOG/ODOT/FHWA funded projects. Specifically, the ENGINEER will perform the following tasks:

- Complete ODOT's regulatory provisions for Standard Environmental review, including field investigations and reports for waters and wetlands, ESA Section 7 assessment, migratory birds and hazardous waste and a cultural resource study
- A noise study will also be completed if necessary.
- Prepare the Adjacent Ownership List and prepare the notification mailout for right-of-entry for environmental clearance. Review & update as necessary.
- Coordinate with ODOT as necessary

Public Meeting

ENGINEER is responsible for facilitating and assisting the OWNER in conducting and documenting Public Meeting(s) associated with the project. Specifically, the ENGINEER will perform the following tasks:

- Conduct the required Public Meeting
- Prepare and publish the required Public Notice advertisement
- Prepare Power Point Presentation and submit to OWNER at least 10 days prior to public meeting and revise as requested
- Attend and present at the Public Meeting as requested by the OWNER
- Prepare responses to questions raised at the Public Meeting
- Prepare meeting minutes
- Prepare various meeting exhibits
- Notify Moore City Council and Politicians of Public Meeting schedule
- Take site pictures of PROJECT

Task 6 - Geotechnical Services (Optional)

Geotechnical Services will be only be utilized by the ENGINEER upon the written approval of the OWNER. It is anticipated that the City's standard typical section will be used, however should Geotechnical Service be required, 2 boring locations have been identified approximately 500 feet from each end on each project, for a total of 4 locations to determine the required pavement design.

Task 7 - Utility Coordination

Utility Map (color-coded)

ENGINEER will provide a color-coded set of plan and profile sheets to each utility company affected as determined and necessary to coordinate the project construction and utility relocations

Utility Relocation Coordination

ENGINEER will coordinate the relocation of utilities and required for the project and will request written approval from all utility companies as to the accuracy of all facilities on the plans.

Utility Meetings

ENGINEER will attend utility relocation meetings with each utility. The meeting will be coordinated with the City of Moore. CONSULANT will prepare the meeting minutes.

Utility Relocation Plan Review

ENGINEER will ensure any utility relocations plans meet the requirements of the project.

Task 8 - Utility Relocations

ENGINEER will determine the horizontal location for waterlines that may need to be relocated prior to construction and provide those locations to the OWNER. The final vertical design and relocation plans will be provided by others.

ENGINEER will include adjustments to waterline and sanitary sewer meters and manholes as part of the design plans for the street improvements.

Task 9 - Bidding Assistance / Construction Supp / As-builts - Roadway

Bidding Assistance

After acceptance by the OWNER of the bidding documents and the most recent opinion of probable Construction Cost as determined in the Final Design Phase, and upon written authorization by OWNER to proceed, ENGINEER shall:

- Attend the Pre-Bid Meeting and provide information as appropriate to clarify, correct, or change the bidding documents.
- Provide information or assistance needed in the course of any bid reviews and/or negotiations with prospective contractors.
- If bidding documents require, ENGINEER shall evaluate and determine the acceptability of "or equals" and substitute materials and equipment proposed by bidders.

Construction Support

Construction Support will consist of the pre-construction meeting, required field meetings, assistance with payment application approvals, RFI reviews, shop drawing review, and periodic (monthly) oversight of construction.

Monthly field meetings and final inspection are anticipated to the site to observe the progress and quality of the work. Written reports on the progress, performance and quality of work shall be provided based upon the visits.

Construction inspection is not included.

As-builts / Record Drawings

Record drawings will be completed based upon field notes, revisions and, changes in plan during construction once the project is closed out. As-built or Record Drawings will be Drawings will be provided in PDF format and electronic (AutoCAD) format.

MEETINGS

ENGINEER shall schedule monthly design progress meetings or conference calls with the OWNER to discuss current project status, upcoming milestones, and any issues arising on the project.

DESIGN CRITERIA

The design and plans shall conform to current (at the time of bidding) Federal, State of Oklahoma, City of Moore, and American Association of State Highway and Transportation Officials (AASHTO) policies and standards unless modified in writing at the direction of the OWNER.

DELIVERABLES

ENGINEER shall provide monthly project status updates that include (but are not limited to) opinion of probable cost updates, schedule updates, action items, and the anticipated submittal date for upcoming milestones. ENGINEER shall make available all design calculations upon request. ENGINEER shall complete thorough quality control reviews prior to the submittal of all deliverables.

Three (3) Review meetings are anticipated for each project; A Preliminary Plan and Design Report Review (30%) and Right-of-Way/Utilities Review (60%) and the Final Field Review (90%). Each submittal will include the appropriate number of plan sets, updated construction cost estimate, and electronic files as required.

The plan sheets below are anticipated for each project: (Sheets anticipated for each submittal in addition to the Final submittal are shown)

- | | |
|--|--|
| 1. Title Sheet (30%, 60%, 90%) | 9. Roadway Details (90%) |
| 2. Typical Sections (30%, 60%, 90%) | 10. Removals (90%) |
| 3. Pay Items List, Quantities and Notes (90%) | 11. Drainage Details (90%) |
| 4. Summary of Quantities (90%) | 12. Signing and Striping (90%) |
| 5. Drainage Map (30%, 60%, 90%) | 13. Sequence of Construction (30%, 60%, 90%) |
| 6. Storm Water Pollution Prevention Plan (90%) | 14. Traffic Control (90%) |
| 7. Erosion Control (90%) | 15. Survey Data Sheets (30%, 60%, 90%) |
| 8. Roadway Plan and Profiles (30%, 60%, 90%) | 16. Cross Sections (60%, 90%) |

The preliminary plan submittal at 30% will be accompanied by a written design analysis (preliminary report). The report will summarize the project scope, approach and design considerations. Proposed solutions will be presented in the report along with estimates and a recommendation. The content of the deliverable will be coordinated with City staff.

SCHEDULE

Unless otherwise agreed, ENGINEER expects to perform its services under the Agreement as follows:

Anticipated Start Date: January 2, 2024
Anticipated Completion Date: April 1, 2025

Project Milestones:

Survey Complete – March 2024
30% Submittal – June 2024
60% Submittal – September 2024
Environmental Complete – October 2024
90% Submittal – January 2025
Final 100% PS&E – March 2025

ENGINEER will endeavor to start its services on the Anticipated Start Date and to complete its services on the Anticipated Completion Date. However, the Anticipated Start Date, the Anticipated Completion Date, and any milestone dates are approximate only, and ENGINEER reserves the right to adjust its schedule and any or all of those dates at its sole discretion, for any reason, including, but not limited to, delays caused by OWNER or delays caused by third parties.

ADDITIONAL SERVICES NOT INCLUDED

Environmental Mitigation Plans
Full time construction inspection or observation
Construction surveying or surveying for as-built conditions
Appraisals, Negotiations & Acquisitions
Utility Relocation Plans

Should OWNER request work in addition to the Scope of Services, ENGINEER shall prepare an amendment for such additional services (Optional Additional Services). ENGINEER shall not commence work on Optional Additional Services without OWNER's prior written approval.

ENGINEER agrees to provide all of its services in a timely, competent and professional manner, in accordance with applicable standards of care, for projects of similar geographic location, quality and scope.

EXHIBIT "B"

FEE TABLE

NE 27th St IMPROVEMENTS

(I-35 to N Eastern Ave)

LUMP SUM FEE REQUEST

NE 27th St IMPROVEMENTS

TASK 1	PROJECT MANAGEMENT	<u>\$ 12,000 LS</u>
TASK 2	SURVEY	<u>\$ 88,500 LS</u>
TASK 3A	PRELIMINARY DESIGN	<u>\$ 100,000 LS</u>
TASK 3B	FINAL DESIGN	<u>\$ 220,000 LS</u>
TASK 4	TRAFFIC DESIGN	<u>\$ 33,400 LS</u>
TASK 5A	ENVIRON. CLEARANCE	<u>\$ 23,925 LS</u>
TASK 5B	ENVIRON. CLEARANCE (PUBLIC MTGS.)	<u>\$ 12,000 LS</u>
TASK 6	GEOTECHNICAL SERVICES (OPTIONAL)	<u>\$ 15,000 LS</u>
TASK 7	UTILITY COORDINATION	<u>\$ 20,000 LS</u>
TASK 8	UTILITY RELOCATION	<u>\$ 6,000 LS</u>
TASK 9	BIDDING, CONSTRUCTION, AS-BUILTS	<u>\$ 20,000 LS</u>
TOTAL AMOUNT		<u>\$ 550,825 LS</u>



Savannah Harris
savannah.harris@jamarshall.com
405.990.1848 cell

John A. Marshall Company, OKC
11400 N I-35 Service Road, Suite E
Oklahoma City, OK 73131

Quote Valid For 30 Days

All Sales Final

Tax Not Included

Revised Quote - Moore Animal Shelter New Location Furniture - 11.22.2023

Line #	Qty	Part Number	Part Description	Sell	Ext Sell
109 MULTIPURPOSE					
1	50	1011FT2.US	Lumin, Wire Rod Frame, Upholstered Seat & Plastic Back, Armless	\$195.50	\$9,775.00
		Frame Information	FC1 Black Frame		
		Caster/Glide Option Selection	CGR Clear Glides		
		Tablet Option Selection	~ No Tablet Upgrade		
		Plastic Shell Color Selection	SC1 Black		
		CA Technical Bulletin 133 Fire Std Option for Fabric	~ No Selection		
		Fabric Grade Selection	FG2 Fabric Grade 2		
		Fabric Grade 2 Selection	ELEMENT Element Standard Color Selection		
		Element Color Selections	ONYX Element Onyx		
		Packaging Options	~ Std Packaging		
2	25	DT5AS.2460LT	+Everywhere Flip-Top Rect Table,Squared Edge,Lam Top/Thermo Edge,T-Leq 24D 60W	\$854.24	\$21,356.00
		Top Finish	LBD @dark brown walnut (non-promote)		
		Edge Finish	LBD @dark brown walnut (non-promote)		
		Leg Finish	BK +black		
		Casters/Glides	20 +casters		
				Subtotal	\$31,131.00

111 MISC. ANIMALS

3	3	1011FT2.US	Lumin, Wire Rod Frame, Upholstered Seat & Plastic Back, Armless	\$195.50	\$586.50
		Frame Information	FC1 Black Frame		
		Caster/Glide Option Selection	CGR Clear Glides		
		Tablet Option Selection	~ No Tablet Upgrade		
		Plastic Shell Color Selection	SC1 Black		
		CA Technical Bulletin 133 Fire Std Option for Fabric	~ No Selection		
		Fabric Grade Selection	FG2 Fabric Grade 2		
		Fabric Grade 2 Selection	ELEMENT Element Standard Color Selection		
		Element Color Selections	ONYX Element Onyx		
		Packaging Options	~ Std Packaging		

Line #	Qty	Part Number	Part Description	Sell	Ext Sell
4	1	DT5AS.1860LT	+Everywhere Flip-Top Rect Table,Squared Edge,Lam Top/Thermo Edge,T-Leq 18D 60W	\$836.38	\$836.38
		Top Finish	LBD @dark brown walnut (non-promote)		
		Edge Finish	LBD @dark brown walnut (non-promote)		
		Leg Finish	BK +black		
		Casters/Glides	20 +casters		
				Subtotal	\$1,422.88

112 ADMIN

5	9	1011FT2.US	Lumin, Wire Rod Frame, Upholstered Seat & Plastic Back, Armless	\$195.50	\$1,759.50
		Frame Information	FC1 Black Frame		
		Caster/Glide Option Selection	CGR Clear Glides		
		Tablet Option Selection	~ No Tablet Upgrade		
		Plastic Shell Color Selection	SC1 Black		
		CA Technical Bulletin 133 Fire Std Option for Fabric	~ No Selection		
		Fabric Grade Selection	FG2 Fabric Grade 2		
		Fabric Grade 2 Selection	ELEMENT Element Standard Color Selection		
		Element Color Selections	ONYX Element Onyx		
		Packaging Options	~ Std Packaging		
				Subtotal	\$1,759.50

154 MANAGER

6	2	1011FT2.US	Lumin, Wire Rod Frame, Upholstered Seat & Plastic Back, Armless	\$195.50	\$391.00
		Frame Information	FC1 Black Frame		
		Caster/Glide Option Selection	CGR Clear Glides		
		Tablet Option Selection	~ No Tablet Upgrade		
		Plastic Shell Color Selection	SC1 Black		
		CA Technical Bulletin 133 Fire Std Option for Fabric	~ No Selection		
		Fabric Grade Selection	FG2 Fabric Grade 2		
		Fabric Grade 2 Selection	ELEMENT Element Standard Color Selection		
		Element Color Selections	ONYX Element Onyx		
		Packaging Options	~ Std Packaging		
7	1	5-1621MPC	Impulse G2 15.625X20.75X21.3125 Mobile Pedestal with Cushion	\$960.12	\$960.12
		Grain Pattern	B4Z Quartered		
		Finish, Quartered Veneer	MMC Mocha (MMC)		
		Pull	Era Era		
		Pull Finish	BKO Onyx		
		Lock	LCK1 Requires 1 Lock Core - Specific Key (Lock Sets Ordered Separately)		
		Grade, 1yd	3 Grade 3 Material		

Line #	Qty	Part Number	Part Description	Sell	Ext Sell
		Grade 3 Material	SWH Spradling Whisper		
		Fabric, Spradling Whisper	3062726 Storm Whi-2155		
8	1	5-2290MCT2	Impulse G2 22x90 Short Grain Modular Cabinet Top	\$552.72	\$552.72
		Grain Pattern	B4Z Quartered		
		Finish, Quartered Veneer	MMC Mocha (MMC)		
		Edge	DN Square - 1"		
		Grommet	G1 No Grommet		
		Grommet Finish	G1 No Grommet		
		Grommet	G1 No Grommet		
		Grommet Finish	G1 No Grommet		
9	1	5-2812SP2	Impulse G2 12"w Support Panel	\$171.36	\$171.36
		Grain Pattern	B4Z Quartered		
		Finish, Quartered Veneer	MMC Mocha (MMC)		
10	1	5-2922MEP2	Impulse G2 20.9375"w End Panel for 22"d Top	\$212.10	\$212.10
		Grain Pattern	B4Z Quartered		
		Finish, Quartered Veneer	MMC Mocha (MMC)		
11	1	5-2990MCB2	Impulse G2 90"w Back Panel	\$490.14	\$490.14
		Grain Pattern	B4Z Quartered		
		Finish, Quartered Veneer	MMC Mocha (MMC)		
		Back	LX Finished Back		
		Wire Access Slot	V7 No Wire Access Slot		
12	1	5-3021MBFC	Impulse G2 30x20.75 Box/Box/File Pedestal	\$821.52	\$821.52
		Grain Pattern	B4Z Quartered		
		Finish, Quartered Veneer	MMC Mocha (MMC)		
		Charging Drawer	X9 None		
		Pull	Era Era		
		Pull Finish	BKO Onyx		
		Lock	LCK1 Requires 1 Lock Core - Specific Key (Lock Sets Ordered Separately)		
13	1	5-3021MFC2	Impulse G2 30x20.75 Lateral File Pedestal	\$821.52	\$821.52
		Grain Pattern	B4Z Quartered		
		Finish, Quartered Veneer	MMC Mocha (MMC)		
		Pull	Era Era		
		Pull Finish	BKO Onyx		
		Lock	LCK1 Requires 1 Lock Core - Specific Key (Lock Sets Ordered Separately)		
14	1	5-4222MCT2	Impulse G2 42x22 Modular Cabinet Top	\$258.30	\$258.30
		Grain Pattern	B4Z Quartered		
		Finish, Quartered Veneer/HPL	MMC Mocha (MMC) -- Ven		

Line #	Qty	Part Number	Part Description	Sell	Ext Sell
		Edge	DN Square - 1"		
		Grommet	G1 No Grommet		
		Grommet Finish	G1 No Grommet		
15	1	5-7230ERTL	Impulse G2 72x30 Executive Left Rectangular Table	\$1,584.66	\$1,584.66
		Grain Pattern	B4Z Quartered		
		Finish, Quartered Veneer/HPL	MMC Mocha (MMC) -- Ven		
		Edge	DN Square - 1"		
		Grommet	G1 No Grommet		
		Modesty Type	KC Wood Veneer		
		Modesty Insert/Color	KC Wood Veneer, No Insert		
		Base	BKO Onyx		
16	1	5-9424HDW6	Impulse G2 94x23.5 6-Door Wallmnt Org w/Paper Management	\$2,359.98	\$2,359.98
		Grain Pattern	B4Z Quartered		
		Finish, Quartered Veneer	MMC Mocha (MMC)		
		Door Type	HC Wood Panel		
		Door Insert/Color	HC Wood Panel/No Insert		
		Lock	NL No Lock (Standard)		
17	1	83043G	Rowen Conversation Sofa w/Arms - Single Textile	\$2,547.72	\$2,547.72
		Button Position	X9 None		
		Button Finish	X9 None		
		Seated Height	LNGH Lounge Height Leg		
		Leg	MAL Metal		
		Leg Finish, Powdercoat	BKO Onyx		
		Ferrule Finish	X9 None		
		Grade	3 Grade 3 Material		
		Grade 3 Material	SWH Spradling Whisper		
		Fabric, Spradling Whisper	3062726 Storm Whi-2155		
18	1	FT2159	Impulse G2 94x18.75 Tackboard	\$376.32	\$376.32
		Grade, Tackboard/VPBoard - 3yds	2 Grade 2 Material		
		Grade 2 Material	OFSR OFS Roam		
		Fabric, OFS Roam	3076081 Rainer		
19	1	LOCK-SET-3	Set of 3 locks and keys. (pack of 3)	\$30.00	\$30.00
		Finish	BLACK Black		
		Key Type	ALIKE Alike		
		Starting Key #, Black	154 154 Non-Standard		
		# of Lock sets	3 3		

Line #	Qty	Part Number	Part Description	Sell	Ext Sell
				Subtotal	\$11,577.46

159 BREAK ROOM

20	3	1011FT2.US	Lumin, Wire Rod Frame, Upholstered Seat & Plastic Back, Armless	\$195.50	\$586.50
		Frame Information	FC1 Black Frame		
		Caster/Glide Option Selection	CGR Clear Glides		
		Tablet Option Selection	~ No Tablet Upgrade		
		Plastic Shell Color Selection	SC1 Black		
		CA Technical Bulletin 133 Fire Std Option for Fabric	~ No Selection		
		Fabric Grade Selection	FG2 Fabric Grade 2		
		Fabric Grade 2 Selection	ELEMENT Element Standard Color Selection		
		Element Color Selections	ONYX Element Onyx		
		Packaging Options	~ Std Packaging		
				Subtotal	\$586.50

163 WAITING/COUNSELING

21	3	1011FT2.US	Lumin, Wire Rod Frame, Upholstered Seat & Plastic Back, Armless	\$195.50	\$586.50
		Frame Information	FC1 Black Frame		
		Caster/Glide Option Selection	CGR Clear Glides		
		Tablet Option Selection	~ No Tablet Upgrade		
		Plastic Shell Color Selection	SC1 Black		
		CA Technical Bulletin 133 Fire Std Option for Fabric	~ No Selection		
		Fabric Grade Selection	FG2 Fabric Grade 2		
		Fabric Grade 2 Selection	ELEMENT Element Standard Color Selection		
		Element Color Selections	ONYX Element Onyx		
		Packaging Options	~ Std Packaging		
22	1	5-1621MFFC2	Impulse G2 15.625X20.75 File/File Pedestal	\$711.06	\$711.06
		Grain Pattern	B4Z Quartered		
		Finish, Quartered Veneer	MMC Mocha (MMC)		
		Pull	Era Era		
		Pull Finish	BKO Onyx		
		Lock	LCK1 Requires 1 Lock Core - Specific Key (Lock Sets Ordered Separately)		
23	1	5-1621MPC	Impulse G2 15.625X20.75X21.3125 Mobile Pedestal with Cushion	\$960.12	\$960.12
		Grain Pattern	B4Z Quartered		
		Finish, Quartered Veneer	MMC Mocha (MMC)		
		Pull	Era Era		
		Pull Finish	BKO Onyx		
		Lock	LCK1 Requires 1 Lock Core - Specific Key (Lock Sets Ordered Separately)		

Line #	Qty	Part Number	Part Description	Sell	Ext Sell
		Grade, 1yd	3 Grade 3 Material		
		Grade 3 Material	SWH Spradling Whisper		
		Fabric, Spradling Whisper	3062726 Storm Whi-2155		
24	1	5-3624HDW2	Impulse G2 36x23.5 2-Door Wallmnt Org w/Paper Management	\$960.54	\$960.54
		Grain Pattern	B4Z Quartered		
		Finish, Quartered Veneer	MMC Mocha (MMC)		
		Door Type	HC Wood Panel		
		Door Insert/Color	HC Wood Panel/No Insert		
		Lock	NL No Lock (Standard)		
25	1	5-4222MCT2	Impulse G2 42x22 Modular Cabinet Top	\$258.30	\$258.30
		Grain Pattern	B4Z Quartered		
		Finish, Quartered Veneer/HPL	MMC Mocha (MMC) -- Ven		
		Edge	DN Square - 1"		
		Grommet	G1 No Grommet		
		Grommet Finish	G1 No Grommet		
26	1	5-6630ERTR	Impulse G2 66x30 Executive Right Rectangular Table	\$1,438.50	\$1,438.50
		Grain Pattern	B4Z Quartered		
		Finish, Quartered Veneer/HPL	MMC Mocha (MMC) -- Ven		
		Edge	DN Square - 1"		
		Grommet	G1 No Grommet		
		Modesty Type	KC Wood Veneer		
		Modesty Insert/Color	KC Wood Veneer, No Insert		
		Base	BKO Onyx		
27	1	FT2169	Impulse G2 36x18.75 Tackboard	\$212.52	\$212.52
		Grade, Tackboard/VPBoard - 1.5yds	2 Grade 2 Material		
		Grade 2 Material	OFSR OFS Roam		
		Fabric, OFS Roam	3076081 Rainer		
28	1	LOCK-SET-2	Set of 2 locks and keys. (pack of 2)	\$30.00	\$30.00
		Finish	BLACK Black		
		Key Type	ALIKE Alike		
		Starting Key #, Black	163 163 Non-Standard		
		# of Lock sets	2 2		

Subtotal \$5,157.54

164 MANAGER

29	1	5-1621MPC	Impulse G2 15.625X20.75X21.3125 Mobile Pedestal with Cushion	\$960.12	\$960.12
		Grain Pattern	B4Z Quartered		

Line #	Qty	Part Number	Part Description	Sell	Ext Sell
		Finish, Quartered Veneer	MMC Mocha (MMC)		
		Pull	Era Era		
		Pull Finish	BKO Onyx		
		Lock	LCK1 Requires 1 Lock Core - Specific Key (Lock Sets Ordered Separately)		
		Grade, 1yd	3 Grade 3 Material		
		Grade 3 Material	SWH Spradling Whisper		
		Fabric, Spradling Whisper	3062726 Storm Whi-2155		
30	1	5-2812SP2	Impulse G2 12"w Support Panel	\$171.36	\$171.36
		Grain Pattern	B4Z Quartered		
		Finish, Quartered Veneer	MMC Mocha (MMC)		
31	1	5-2922MEP2	Impulse G2 20.9375"w End Panel for 22"d Top	\$212.10	\$212.10
		Grain Pattern	B4Z Quartered		
		Finish, Quartered Veneer	MMC Mocha (MMC)		
32	1	5-2930MCB2	Impulse G2 30"w Back Panel	\$226.80	\$226.80
		Grain Pattern	B4Z Quartered		
		Finish, Quartered Veneer	MMC Mocha (MMC)		
		Back	LX Finished Back		
		Wire Access Slot	V7 No Wire Access Slot		
33	1	5-2978MCB2	Impulse G2 78"w Back Panel	\$580.02	\$580.02
		Grain Pattern	B4Z Quartered		
		Finish, Quartered Veneer	MMC Mocha (MMC)		
		Back	LX Finished Back		
		Wire Access Slot	V8 With Wire Access Slot		
34	1	5-3021MBFC	Impulse G2 30x20.75 Box/Box/File Pedestal	\$821.52	\$821.52
		Grain Pattern	B4Z Quartered		
		Finish, Quartered Veneer	MMC Mocha (MMC)		
		Charging Drawer	X9 None		
		Pull	Era Era		
		Pull Finish	BKO Onyx		
		Lock	LCK1 Requires 1 Lock Core - Specific Key (Lock Sets Ordered Separately)		
35	1	5-3021MFC2	Impulse G2 30x20.75 Lateral File Pedestal	\$821.52	\$821.52
		Grain Pattern	B4Z Quartered		
		Finish, Quartered Veneer	MMC Mocha (MMC)		
		Pull	Era Era		
		Pull Finish	BKO Onyx		
		Lock	LCK1 Requires 1 Lock Core - Specific Key (Lock Sets Ordered Separately)		
36	1	5-3022MCT2	Impulse G2 30x22 Modular Cabinet Top	\$235.62	\$235.62

Line #	Qty	Part Number	Part Description	Sell	Ext Sell
		Grain Pattern	B4Z Quartered		
		Finish, Quartered Veneer/HPL	MMC Mocha (MMC) -- Ven		
		Edge	DN Square - 1"		
		Grommet	G1 No Grommet		
		Grommet Finish	G1 No Grommet		
37	1	5-3043WSC	Impulse G2 30x42.5 Worksurface Cabinet w/Doors	\$1,315.02	\$1,315.02
		Grain Pattern	B4Z Quartered		
		Finish, Quartered Veneer	MMC Mocha (MMC)		
		Back	LW Unfinished Back		
		Door Type	HC Wood Panel		
		Door Insert/Color	HC Wood Panel/No Insert		
		Pull	A5 No Pull		
		Pull Finish	X9 None		
		Lock	NL No Lock (Standard)		
38	1	5-4222MCT2	Impulse G2 42x22 Modular Cabinet Top	\$258.30	\$258.30
		Grain Pattern	B4Z Quartered		
		Finish, Quartered Veneer/HPL	MMC Mocha (MMC) -- Ven		
		Edge	DN Square - 1"		
		Grommet	G1 No Grommet		
		Grommet Finish	G1 No Grommet		
39	1	5-6630ERTL	Impulse G2 66x30 Executive Left Rectangular Table	\$1,438.50	\$1,438.50
		Grain Pattern	B4Z Quartered		
		Finish, Quartered Veneer/HPL	MMC Mocha (MMC) -- Ven		
		Edge	DN Square - 1"		
		Grommet	G1 No Grommet		
		Modesty Type	KC Wood Veneer		
		Modesty Insert/Color	KC Wood Veneer, No Insert		
		Base	BKO Onyx		
40	1	5-7822MCT2	Impulse G2 78x22 Modular Cabinet Top	\$484.26	\$484.26
		Grain Pattern	B4Z Quartered		
		Finish, Quartered Veneer/HPL	MMC Mocha (MMC) -- Ven		
		Edge	DN Square - 1"		
		Grommet	G1 No Grommet		
		Grommet Finish	G1 No Grommet		
41	1	5-7824HDW4	Impulse G2 78x23.5 4-Door Walimnt Org w/Paper Management	\$1,745.52	\$1,745.52
		Grain Pattern	B4Z Quartered		
		Finish, Quartered Veneer	MMC Mocha (MMC)		

Line #	Qty	Part Number	Part Description	Sell	Ext Sell
		Door Type	HC Wood Panel		
		Door Insert/Color	HC Wood Panel/No Insert		
		Lock	NL No Lock (Standard)		
42	1	FT2162	Impulse G2 78x18.75 Tackboard	\$259.14	\$259.14
		Grade, Tackboard/VPBoard - 2.5yds	2 Grade 2 Material		
		Grade 2 Material	OFSR OFS Roam		
		Fabric, OFS Roam	3076081 Rainer		
43	1	LOCK-SET-3	Set of 3 locks and keys. (pack of 3)	\$30.00	\$30.00
		Finish	BLACK Black		
		Key Type	ALIKE Alike		
		Starting Key #, Black	164 164 Non-Standard		
		# of Lock sets	3 3		
				Subtotal	\$9,559.80

BENCHES

44	11	BWB-16-64-RTR-18	GRAND RAPIDS BOWEN OUTDOOR BENCH	\$1,035.00	\$11,385.00
		TOP	HDPE- WALNUT		
		BASE	STANDARD GRC POWDERCOAT: INK BLACK		
			PLASTIC GLIDES		
				Subtotal	\$11,385.00

TASK CHAIRS

45	4	1560-Y2-A7	Strata - Mid-Back, Synchro-Tilt Control, A7 Height & Width Adj. Arm with Pivot & Swivel Pad	\$682.53	\$2,730.12
		Fabric Grade Selection	GRADE-C Fabric Grade C		
		Grade C Fabrics	CANTER Momentum - Canter		
		Canter Colors	ONYX3022 Onyx 3022		
		Frame Color	BF Black Frame		
		Base Selection	BA2B BA2B 26" Aluminum Base - Black Powder Coat		
		Casters Selection	C1S C1S Hard Floor and Carpet Casters		
		Seat Slider Selection	SS Seat Slider 2.5" Side Paddle Activated		
		Heavy Duty Multi-Shift Option (350 lbs.) Selection	HD Heavy Duty Upgrade		
		CAL TB 133 Fire Barrier	~ No Cal TB 133 (standard upholstery)		
				Subtotal	\$2,730.12

X-FREIGHT

46	1		9 to 5 Fuel Surcharge	\$111.72	\$111.72
47	1		FREIGHT GRAND RAPIDS TO OKC	\$1,433.33	\$1,433.33
				Subtotal	\$1,545.05

Z - DELIVERY AND INSTALL

Line #	Qty	Part Number	Part Description	Sell	Ext Sell
48	1		Delivery and Install	\$6,695.00	\$6,695.00

Subtotal \$6,695.00

ZZ - TBD

49	1		PODIUM- PRODUCT TBD	\$0.00	\$0.00
----	---	--	---------------------	--------	--------

Subtotal \$0.00

Grand Total \$83,549.85

Customer Signature: _____

Medical Claims and Total Costs Summary 1-1-24

FIRM

Administrator		<u>Renewal</u> ABA
Stop Loss Carrier		Ironshore
Network Access Pharmacy (PBM/Formulary)		UnitedHealthcare Elixir
Specific Deductible		\$135,000
Aggregating Specific Laser		\$36,500 N/A
TOTAL FIXED COST		\$1,028,970.72
ESTIMATED CLAIMS - MAXIMUM		
Employee	89	\$820.43
Family	269	\$1,900.30
Annual Maximum Claims		\$7,010,387.64
Annual Dollar Difference		-\$291,989.28
Percent Change		-4.00%
ESTIMATED CLAIMS - EXPECTED		
Employee	89	\$656.34
Family	269	\$1,520.24
Monthly Claims		\$467,358.82
Annual Claims		\$5,608,305.84
Annual Dollar Difference		-\$234,812.88
Percent Change		-4.02%
TOTAL MAXIMUM PLAN COST		
Annual Total		\$8,039,358.36
Annual Dollar Difference		-\$293,359.44
Percent Change		-3.52%
TOTAL EXPECTED PLAN COST		
Annual Total		\$6,637,276.56
Annual Dollar Difference		-\$236,183.04
Percent Change		-3.44%
RX REBATES/CREDITS		
Annual Estimated Rebates/Credits		\$403,000.00
TOTAL MAXIMUM PLAN COST - RX REBATES/CREDITS		
Maximum Plan Cost after Rebates/Credits		\$7,636,358.36
Annual Dollar Difference		-\$326,359.44
Percent Change		-4.10%
TOTAL EXPECTED PLAN COST - RX REBATES/CREDITS		
Expected Plan Cost after Rebates/Credits		\$6,234,276.56
Annual Dollar Difference		-\$269,183.04
Percent Change		-4.14%



Employer	City of Moore	Quote ID	20743
Eff. Date	1/1/2024	Proposal ID	27026

The terms of this offer are tentative and subject to change based on receipt, review and approval of the following:

- Quote assumes utilization of the following network: UHC

If this changes rates and factors will be adjusted accordingly.

Proposal assumes ABA will administer all claims and Elixir will be the PBM vendor.

Proposal is firm/final until 11/10/23. After this time, updated information is required for review/approval.

Proposal is based on the current benefit plans.

Quote requires a conditional laser on . If dialysis occurs during the 2024 policy period, \$300,000 laser will apply.
- Specific Advance Funding is included
- Aggregating Specific Deductible is included.
 - * Only eligible claim amounts in excess of the Specific individual deductible/laser are applied to the Aggregating Specific coverage
 - * Does not accumulate towards the Aggregate Attachment Point.
- Only the amount up to the group specific deductible applies toward the aggregate for lasered individuals
- Requirements to finalize underwriting:
 - Updated disclosure reporting (i.e. large claimant report, pre-cert, CM and trigger dx reports, pending/unpaid reporting) NO earlier than 60 days prior to effective date
 - Completed and Signed Disclosure within 10 business days of firm proposal issuance
 - Monthly enrollment/claims reporting through the effective date
 - Medical Applications completed no earlier than 60 days prior to renewal if no experience available
 - Binder Premium on or before the effective date
 - Final census
 - Signed Proposal within 10 business days of firm proposal issuance
 - All final underwriting materials
- DRM reserves the right to revise rates, factors, deductibles, terms or conditions of the contract on any of the following circumstances
 - When the Contractholder adds or deletes any subsidiary or affiliate;
 - When there is a change in geographical area in which the Contractholder is located;
 - When there is a change in the nature of business in which the contractholder is engaged;
 - When there is a increase or decrease in the number of covered units which exceeds 10% in any one month or 20% over any period of three consecutive months.
 - When a proven medical misstatement has occurred on a Contractholder Individual Application or Disclosure.
- Any person who is disclosed as terminated from the plan or not active on the plan as of the effective date is excluded from coverage and would be subject to Medical Underwriting for consideration to rejoin the plan.
- If retiree coverage is requested, this proposal assumes that Medicare is primary for retirees age 65 and over.
- Administration costs and network access fees are not included in the stop loss costs or coverage



Employer	City of Moore	Quote ID	20743
Eff. Date	1/1/2024	Proposal ID	27026

The terms of this offer are tentative and subject to change based on receipt, review and approval of the following:

Claims negotiation fees for NON-Network claims are limited to 25% of savings.
LCM Fees are limited to \$ 145.00 per hour.

- DRM reserves the right to re-underwrite the case should a large claim(s), (non-reoccurring and/or ongoing) become known and the initial date of service is prior to the date of written acceptance by DRM.
- Enrollment Requirements:
An enrolled census as of the effective date is required to bind
This quote is based on the enrollment shown on the proposal page. If the actual enrollment varies by more than 15 % we reserve the right to re-rate the case
Maximum 5% COBRA Participation
Maximum 10% of enrolled population may be non-medicare primary retirees
Minimum participation of 70% of all eligible employees is required unless approved by Dallas Risk Management
- A final signed plan document and all signed amendments for the coverage period. We must review and approve all plan documents to verify that benefits correspond with those assumed when we prepared our quote. Any changes in benefits could result in changes to rates and factors.
- This quote is based on the information supplied. We reserve the right to make changes if any of the information that the quote is based on changes. This is not a binder or contract of insurance.
- This quote is subject to Dallas Risk Management's approval of the proposed TPA.
- Quote assumes producer holds adequate licensure in any required state
- YOU MUST NOTIFY IN WRITING THE UNDERWRITER OF THE QUOTE IF YOU DO NOT MEET THE ABOVE CONDITIONS / ASSUMPTIONS
- Administration and Network Access Fees are not eligible for reimbursement under the Specific or Aggregate Coverage

CLAIMS FOR RATIFICATION
MOORE PUBLIC WORKS AUTHORITY
COUNCIL MEETING DECEMBER 18, 2023

Moore City Council
M.P.W.A. 2023-2024
Vendor & Employee Claims

Moore, OK Purchase Order Claim Register



Fund: 02 - Risk Management

Check Run : 113023

Department: 025 - Risk Management

P.O. #	Vendor #	Name	Summary Description	Date	Invoice	Amount
240336	324	BARBARA ARNETT	MEDICARE REIMBURSEMENT JULY 2023-JUNE 2024	11/6/2023	100828	300.00
		02010250 - 52725 -	Medicare Reimbursement			
240284	493	ALMA BUMGARNER	MEDICARE REIMBURSEMENT JULY 2023-JUNE 2024	11/5/2023	100829	300.00
		02010250 - 52725 -	Medicare Reimbursement			
240273	180	KEN FRASER	MEDICARE REIMBURSEMENT JULY 2023-JUNE 2024	12/1/2023	100830	300.00
		02010250 - 52725 -	Medicare Reimbursement			
240302	1990	LYNDELL MITCHELL	MEDICARE REIMBURSEMENT JULY 2023-JUNE 2024	9/5/2023	100831	685.65
		02010250 - 52725 -	Medicare Reimbursement			
240314	2999	TIPPY W. PIERCE	MEDICARE REIMBURSEMENT JULY 2023-JUNE 2024	12/1/2023	100832	300.00
		02010250 - 52725 -	Medicare Reimbursement			
240341	530	SIMPSON, DENISE	MEDICARE REIMBURSEMENT JULY 2023-JUNE 2024	11/1/2023	100833	243.72
		02010250 - 52725 -	Medicare Reimbursement			
240990	3096	CLASSEN URGENT CARE CLINIC LLC	CITY OF MOORE EMPLOYEE ON- SITE FLU CLINIC	11/24/2023	100903	3,570.00
		02010250 - 52710 -	Health Claims			
240316	3096	CLASSEN URGENT CARE CLINIC LLC	MONTHLY PRE- EMPLOYMENT/RANDOM DRUG SCREENS	11/1/2023	100911	105.00
		02010250 - 52645 -	Physicals, Drug Testing, Etc.			

Department Total :	5,804.37
Fund Total :	5,804.37

Moore, OK Purchase Order Claim Register



Fund: 05 - Moore Public Works Authority

Check Run : 113023

Department: 000 - Undesignated

P.O. #	Vendor #	Name	Summary Description	Date	Invoice	Amount
	1	ONE TIME PAY VENDOR	DEREK CRAWFORD CASE # J009689 427.89	11/7/2023	100212	427.89
	5 - 13050 -		Utility Accounts Receivable			
Department Total :						427.89

Department: 035 - General Government

P.O. #	Vendor #	Name	Summary Description	Date	Invoice	Amount
240760	2855	PRESORT FIRST CLASS	PRINTING & MAILING OF WATER BILL, ESTIMATED	11/6/2023	100369	1,022.93
	05010350 - 52000 -		Printing & Publications			
241049	2172	OKLAHOMA ONE CALL SYSTEM INC	TICKET FEE COM	11/8/2023	100370	7,518.15
	05010350 - 52545 -		Miscellaneous Services & Charg			
240451	103	OKLAHOMA GAS & ELECTRIC	ELECTRICITY	11/16/2023	100666	300.28
	05010350 - 52100 -		Electricity			
241533	666	BANK OF OKLAHOMA	FAP-19-0003-L LOAN PAYMENTS	12/1/2023	100817	70,089.30
	05010350 - 54512 -		Debt Service - 2019 OWRB			
240082	666	BANK OF OKLAHOMA	ORF-08-0002-CW	12/1/2023	100819	13,177.91
	05010350 - 54500 -		Debt Service - 2009 OWRB			
240069	666	BANK OF OKLAHOMA	ORF-08-0002-CWA	12/1/2023	100820	228,966.29
	05010350 - 54505 -		Debt Service - OWRB \$42M Loan			
240081	666	BANK OF OKLAHOMA	ORF-10-0012-CW	12/1/2023	100821	35,002.58
	05010350 - 54510 -		Debt Service - OWRB \$6M Loan			
240200	1727	OKLAHOMA NATURAL GAS	NATURAL GAS, COMBINED	11/21/2023	100836	344.62
	05010350 - 52105 -		Natural Gas			
Department Total :						356,422.06

Department: 066 - Sanitation

P.O. #	Vendor #	Name	Summary Description	Date	Invoice	Amount
241949	2923	WARREN PRODUCTS, INC.	CALENDARS FOR 2024- SANITATION	11/7/2023	100232	23.24
	05040660 - 51000 -		General Office Supplies			
240547	3412	SIERRA CONTAINER GROUP LLC	Blanket PO for 1404 Polycarts for use during 2024	11/7/2023	100387	43,527.40
	05040660 - 51165 -		Poly Cart Purchases			
241998	4015	EXPRESS SERVICES INC	Express Employment for Temporary Employees	11/8/2023	100400	763.39
	05040660 - 52350 -		Temporary Labor			
242006	1214	MOORE TAG AGENCY, INC	TAG FOR NEW TRASH TRUCK	11/6/2023	100642	65.50
	05040660 - 51150 -		Minor Equipment			
Department Total :						44,379.53
Fund Total :						401,229.48

CLAIMS FOR RATIFICATION
MOORE PUBLIC WORKS AUTHORITY
COUNCIL MEETING DECEMBER 18, 2023

Moore City Council
M.P.W.A. 2023-2024
Vendor & Employee Claims

Moore, OK Purchase Order Claim Register



Fund: 02 - Risk Management

Check Run : 120723

Department: 025 - Risk Management

P.O. #	Vendor #	Name	Summary Description	Date	Invoice	Amount
242145	1222	BOSS PRINT DESIGN, INC	REPLACEMENT OF WRAP MATERIALS ON POLICE UNIT	11/15/2023	100644	65.00
		02010250 - 52362 -	Collision Repairs			
240421	1872	WRIGHT EXPRESS FSC	CITY WIDE FUEL USAGE	11/30/2023	101020	29.22
		02010250 - 51075 -	Fuel			
240279	326	GARY BENEFIELD	MEDICARE REIMBURSEMENT JULY 2023-JUNE 2024	12/1/2023	101093	279.70
		02010250 - 52725 -	Medicare Reimbursement			
240288	519	GENE MILLER	MEDICARE REIMBURSEMENT JULY 2023-JUNE 2024	10/2/2023	101094	900.00
		02010250 - 52725 -	Medicare Reimbursement			
240291	529	WILLIAM T SHULTZ	MEDICARE REIMBURSEMENT JULY 2023-JUNE 2024	10/5/2023	101095	900.00
		02010250 - 52725 -	Medicare Reimbursement			
240271	174	GARY TIPPS	MEDICARE REIMBURSEMENT JULY 2023-JUNE 2024	11/6/2023	101096	162.08
		02010250 - 52725 -	Medicare Reimbursement			
240277	316	STEWART, LINDA	MEDICARE REIMBURSEMENT JULY 2023-JUNE 2024	12/5/2023	101103	300.00
		02010250 - 52725 -	Medicare Reimbursement			
240270	161	KOONCE, LOUISE	MEDICARE REIMBURSEMENT JULY 2023-JUNE 2024	12/5/2023	101142	300.00
		02010250 - 52725 -	Medicare Reimbursement			
240298	990	JOHN BARNETT	MEDICARE REIMBURSEMENT JULY 2023-JUNE 2024	12/1/2023	101165	275.90
		02010250 - 52725 -	Medicare Reimbursement			
240301	1773	KEN STREETER	MEDICARE REIMBURSEMENT JULY 2023-JUNE 2024	7/3/2023	101177	1,800.00
		02010250 - 52725 -	Medicare Reimbursement			
240307	2671	TWO OAKS INVESTMENTS, LLC	MONTHLY TPA SERVICES FOR WC/GL 7-23-12-23	11/30/2023	101194	1,700.00
		02010250 - 52665 -	TPA WC/GL Services			
240286	500	STAN DRAKE	MEDICARE REIMBURSEMENT JULY 2023-JUNE 2024	9/6/2023	101195	505.41
		02010250 - 52725 -	Medicare Reimbursement			
240315	3032	BARBARA J. MEZA	MEDICARE REIMBURSEMENT JULY 2023-JUNE 2024	12/5/2023	101204	298.27
		02010250 - 52725 -	Medicare Reimbursement			

Department Total :	7,515.58
Fund Total :	7,515.58

Moore, OK Purchase Order Claim Register



Fund: 05 - Moore Public Works Authority

Check Run : 120723

Department: 035 - General Government

P.O. #	Vendor #	Name	Summary Description	Date	Invoice	Amount
240760	2855	PRESORT FIRST CLASS 05010350 - 52000 -	PRINTING & MAILING OF WATER BILL, ESTIMATED Printing & Publications	11/13/2023	100564	550.15
240260	2855	PRESORT FIRST CLASS 05010350 - 51200 -	MAILING FEES 1 YEAR ESTIMATED POSTAGE Postage	12/1/2023	100813	12,000.00
240451	103	OKLAHOMA GAS & ELECTRIC 05010350 - 52100 -	ELECTRICITY Electricity	11/22/2023	100905	140.39
241174	934	VEOLIA WATER NORTH AMERICA 05010350 - 52415 -	REPAIR & MAINTENANCE (costs in excess) R-Account (Parts/Repairs)	10/23/2023	100978	274,911.76
Department Total :						287,602.30

Department: 066 - Sanitation

P.O. #	Vendor #	Name	Summary Description	Date	Invoice	Amount
240638	1755	HOME DEPOT CREDIT SERVICES 05040660 - 51250 -	SUPPLIES FOR SANITATION TRUCKS i.e. RATCHET STRAP Misc. Materials & Supplies	11/16/2023	100598	26.98
241038	2533	SPARQ NATURAL GAS, LLC 05040660 - 51075 -	CNG USAGE FOR PUBLIC WORKS YEAR 2023-2024 Fuel	11/16/2023	100602	12,332.38
241998	4015	EXPRESS SERVICES INC 05040660 - 52350 -	Express Employment for Temporary Employees Temporary Labor	11/14/2023	100638	637.36
240421	1872	WRIGHT EXPRESS FSC 05040660 - 51075 -	CITY WIDE FUEL USAGE Fuel	11/30/2023	101020	655.26
Department Total :						13,651.98
Fund Total :						301,254.28

PROPOSAL OF INSURANCE

JAN. 1, 2024 – JAN. 1, 2025

PREPARED SPECIFICALLY FOR:

City of Moore & Public Works Authority
301 North Broadway
Moore, OK 73160



Presented By: Greg Finch

Glenn Harris & Associates Insurance
PO Box 21887 Oklahoma City, OK 73156
Ofc: (405) 842.5385
greg@ghainsurance.com

This Document is a Proposal of Insurance. Actual Terms and Conditions of Coverage Are Determined by The Insurance Policies.

YOUR SERVICE TEAM

Ensuring you and your employees receive prompt, professional and quality service is a key goal of Glenn Harris and Associates.

PERSONAL CONTACT INFORMATION:



Greg Finch, Producer
Phone: 405-842-5385, ext 111
Mobile: 405-323-2061
Email: greg@ghainsurance.com

Greg is your contact for identifying key coverage needs for your business, securing bids for review, and finalizing coverage based on your selections.



Richard Nickels, Account Manager
Phone: Office: 405-842-5385, **Cell:** 405-822-5607
Email: rnickels@ghainsurance.com

Richard is your main contact for all your day-to-day questions or needs including coverage questions, billing, claims support, insurance cards, certificates, and more.



Laurie Bly, Commercial Lines Manager
Phone: 405-842-5385, ext 115
Mobile: 405-740-5374
Email: lbly@ghainsurance.com

Laurie can assist with any detailed questions you may have regarding your policy, renewals, or additional coverage you may need throughout the year.

AGENCY CONTACT INFORMATION:

Glenn Harris and Associates Insurance, LLC
13800 Quail Pointe Dr
Oklahoma City, OK 73134
Main Line: 405-842-5385
Fax: 405-840-4655
www.ghainsurance.com

LIABILITY (PUBLIC OFFICIALS/EPLI)

INSURANCE CARRIER: INDIAN HARBOR INSURANCE COMPANY
TERM PERIOD: JANUARY 1, 2024 THRU JANUARY 1, 2025

Description	Limit
Public Official Management	\$3,000,000
Employment Practices Liability	\$3,000,000
Policy Aggregate	\$3,000,000
Non-Monetary Coverage – Defense Only	\$100,000
Non-Monetary Coverage – Defense Only Aggregate	\$100,000
Crisis Management	\$25,000
RETENTIONS	
Public Officials Management Retention	\$250,000
Employment Practices Liability Retention	\$250,000
Non-Monetary Coverage – Defense Only	\$250,000
Crisis Management	\$5,000

NOTES:

Claims Made Form

Retro Date – None, Full Prior Acts

SUMMARY OF PREMIUM

RENEWAL PREMIUM VS. EXPIRING PREMIUM

Line of Business	Expiring Premiums	Renewal Premiums
<i>EPLI/Public Officials Liability</i>	\$ 42,342.00	\$ 49,580.44
Total Premium	\$42,342.00	\$49,580.44

ADDITIONAL NOTES:

Policy written through Indian Harbor Insurance Company as expiring company (Hudson Insurance Company) no longer writing this type of coverage.

MARKETING SUMMARY

TERM PERIOD: JANUARY 1, 2024 THRU JANUARY 1, 2025

Coverage	Carrier	Quoted Premium	Declined	Declination Reason
Public Officials - EPLI	Superior Specialty Ins	\$53,410.22		
	Richmond National Ins	\$51,387.74		
	Kinsale Ins. Co.	\$65,034.18		
	Euclid Managers	n/a	X	Min prem 100k
	RPS	n/a	X	No quote recd.

PROPOSAL ACCEPTANCE

TERM PERIOD: JANUARY 1, 2024 THRU JANUARY 1, 2025

Acceptance of Proposal:

I agree that coverage outlined in this Proposal applies only to the Named Insureds, locations, scheduled vehicles, and lines of coverage detailed within this proposal. Coverage for entities not listed is written with other agents.

Notes / Exceptions:

Policyholder Signature:

Date:

PROPOSAL ACCEPTANCE

LINES OF BUSINESS	EXPIRING *	RENEWAL
Primary Property	\$351,317.00	\$446,856
Excess Property – Full \$70,000,000 XS of \$100,000,000	\$50,000.00	N/A
RSUI \$45,000,000 XS of \$100,000,000		\$100,000
Excess Flood - Property	\$44,061.02**	\$44,061.02**
Equipment Floater	\$66,245.00	\$160,000.00***
Cyber Liability	\$50,000.00***	\$50,000.00****
Policy Fee	\$500.00	\$500.00
Account Management Fee	\$50,000.00	\$50,000.00
Total Premium	\$612,123.02	\$851,417.02

- * Renewal premium basis x expiring rates
- ** includes agent commission totaling \$4,364.50.
- ***Minimum Premium \$50,000
- **** included agent commission totaling \$5,000.00

Excess Property policy is 25% minimum earned premium at inception.
 Cyber Policy all fees fully earned & No flat cancellation

*****Per Senate Bill No. 66, Section K.) Policies sold to any city or town in this state, incorporated pursuant to law, or to any school district, as defined in Section 1-108 of Title 70 of the Oklahoma Statutes, shall be exempt from the surplus lines premium tax. \$3,030.00 will be returned to you for the 2022-2023 policy term.

Premium Payment Options: Payment due at inception payable to Dillingham Insurance Agency

Contingencies:

- Property –
 - Signed Accord Form – due at binding
 - Signed SOV
 - Terrorism Coverage Form completed and signed
- Excess Property – Signed Acord application, signed and dated SOV, Signed and completed Terrorism form
- Excess Flood – Signed Offer letter and signed Loss history letter
- Equipment Floater – Signed Terrorism Form

**RISK MANAGEMENT PROGRAM CLAIMS AND EXPENSES FOR
DECEMBER 18, 2023**

<u>Description</u>	<u>Amount</u>
Health Claims	308,163.99
Workers' Compensation Claims	4,103.51
General Liability Claims	359.70
Total	\$312,627.20

DAILY CHECK REGISTER

First Fidelity Bank
City of Moore (70009)

Check Number	Chk/EFT	Check Date	Type Expense	Cvg Type	Emp/Dep	Over Spec	Check Amount	Claim Number	Employee	Payee
00715926	C	11/28/2023	DRUG	DRUG	EMP		\$43,347.10	2023-324000061-0000		HUNTER LANE, LLC
1 CHECKS PAID AMOUNTING TO \$43,347.10 ✓			1 PAYMENTS AMOUNTING TO \$43,347.10			ELECTRONIC PAYMENTS AMOUNTING TO \$0.00			0 TOTAL ADJUSTMENTS FOR \$0.00	
BREAKDOWN			Medical	Dental	Vision	Drug	Other	Excess		
CHECKS			0	0	0	1	0	0		
TOTALS			\$0.00	\$0.00	\$0.00	\$43,347.10	\$0.00	\$0.00		

DAILY CHECK REGISTER

City of Moore (70009)

First Fidelity Bank
City of Moore (79023)

Check Number	Chk/ EFT	Check Date	Type Expense	Cvg Type	Emp/ Dep	Over Spec	Check Amount	Claim Number	Employee	Payee
00715927	C	11/28/2023	MEDICAL	0011	EMP		\$247.50	2023-317001842-0000		HPI PHYSICIANS LLC
00715928	C	11/28/2023	MEDICAL	0018	EMP		\$81.00	2023-318000696-0000		SPARKS CLINIC
00715929	C	11/28/2023	MEDICAL	0010	DEP		\$97.76	2023-319004472-0000		INTEGRIS MEDICAL GROUP
00715930	C	11/28/2023	MEDICAL	0333	EMP		\$186.48	2023-312000933-0000		NORMAN REGIONAL HOSPITAL AUTI
00715931	C	11/28/2023	MEDICAL	0039	EMP		\$135.60	2023-320000964-0000		INTERNAL MEDICINE-DOCTOR'S PAF
00715932	C	11/28/2023	MEDICAL	0017	DEP		\$49.50	2023-314002169-0000		THERAPY IN MOTION OF OKLAHOM/
00715933	C	11/28/2023	MEDICAL	0017	DEP		\$49.50	2023-314002170-0000		THERAPY IN MOTION OF OKLAHOM/
00715934	C	11/28/2023	MEDICAL	0017	DEP		\$49.50	2023-320000970-0000		THERAPY IN MOTION OF OKLAHOM/
00715935	C	11/28/2023	MEDICAL	0010	DEP		\$81.70	2023-317001756-0000		XPRESS WELLNESS URGENT CARE
00715936	C	11/28/2023	MEDICAL	0010	DEP		\$96.58	2023-317001950-0000		INTEGRIS MEDICAL GROUP
00715937	C	11/28/2023	MEDICAL	0153	EMP		\$78.30	2023-313000834-0000		CLASSEN URGENT CARE CLINIC LLC
00715938	C	11/28/2023	MEDICAL	0010	EMP		\$73.65	2023-320001554-0000		CANADIAN VALLEY FAMILY CARE
00715939	C	11/28/2023	MEDICAL	0153	DEP		\$34.41	2023-313000635-0000		MEDICAL RESOURCE MANAGEMENT
00715940	C	11/28/2023	MEDICAL	0010	DEP		\$71.20	2023-312000515-0000		BODIN CHIROPRACTIC PLLC
00715941	C	11/28/2023	MEDICAL	0177	DEP		\$8.00	2023-312000694-0000		DIAGNOSTIC LABORATORY OF OKLU
00715942	C	11/28/2023	MEDICAL	0019	DEP		\$234.00	2023-319000329-0000		BODIN CHIROPRACTIC PLLC
00715943	C	11/28/2023	MEDICAL	0177	EMP		\$116.95	2023-319000599-0000		LABORATORY CORPORATION OF AN
00715944	C	11/28/2023	MEDICAL	0009	DEP		\$201.96	2023-314001990-0000		OU HEALTH PARTNERS INC
00715945	C	11/28/2023	MEDICAL	0073	DEP		\$47.97	2023-313000859-0000		PHYSICIAN MANAGEMENT SERVICES
00715946	C	11/28/2023	MEDICAL	0010	EMP		\$65.14	2023-319003940-0000		INTEGRIS MEDICAL GROUP
00715947	C	11/28/2023	MEDICAL	0153	DEP		\$78.30	2023-320001579-0000		CLASSEN URGENT CARE CLINIC LLC
00715948	C	11/28/2023	MEDICAL	0153	DEP		\$78.30	2023-320001580-0000		CLASSEN URGENT CARE CLINIC LLC
00715949	C	11/28/2023	MEDICAL	0153	DEP		\$78.30	2023-313000833-0000		CLASSEN URGENT CARE CLINIC LLC
00715950	C	11/28/2023	MEDICAL	0035	EMP		\$46.20	2023-319003280-0000		INTEGRIS MEDICAL GROUP
00715951	C	11/28/2023	MEDICAL	0153	EMP		\$78.30	2023-311001129-0000		CLASSEN URGENT CARE CLINIC LLC
00715952	C	11/28/2023	MEDICAL	0072	EMP		\$637.50	2023-268000135-0000		ORTHO CENTRAL SURGERY CENTER

DAILY CHECK REGISTER

City of Moore (70009)

First Fidelity Bank
 City of Moore (79023)

Check Number	Chk/EFT	Check Date	Type Expense	Cvg Type	Emp/Dep	Over Spec	Check Amount	Claim Number	Employee	Payee
00715953	C	11/28/2023	MEDICAL	0066	EMP		\$335.69	2023-317001195-0000		VANTAGE OPEN MRI DIAGNOSTIC IM
00715954	C	11/28/2023	MEDICAL	0010	DEP		\$91.39	2023-318000717-0000		COMPREHENSIVE PAIN CENTER
00715955	C	11/28/2023	MEDICAL	0153	DEP		\$78.30	2023-317001671-0000		CLASSEN URGENT CARE CLINIC LLC
00715956	C	11/28/2023	MEDICAL	0177	DEP		\$25.98	2023-320001637-0000		QUEST DIAGNOSTICS LENEXA
00715957	C	11/28/2023	MEDICAL	0177	EMP		\$41.55	2023-312000699-0000		DIAGNOSTIC LABORATORY OF OKLA
00715958	C	11/28/2023	M/N	0020	DEP		\$103.25	2023-312001022-0000		SPECTRUM BEHAVIORAL HEALTH GF
00715959	C	11/28/2023	MEDICAL	0010	DEP		\$87.31	2023-317001891-0000		STANBORO HEALTHCARE GROUP LL
00715960	C	11/28/2023	MEDICAL	0039	EMP		\$114.24	2023-319005317-0000		DR BRIAN E THATCHER
00715961	C	11/28/2023	MEDICAL	0004	DEP		\$212.40	2023-317000245-0000		OU MEDICINE INC
00715962	C	11/28/2023	MEDICAL	0153	EMP		\$78.30	2023-317001678-0000		CLASSEN URGENT CARE CLINIC LLC
00715963	C	11/28/2023	MEDICAL	0153	DEP		\$78.30	2023-317001682-0000		CLASSEN URGENT CARE CLINIC LLC
00715964	C	11/28/2023	MEDICAL	0153	DEP		\$78.30	2023-311001133-0000		CLASSEN URGENT CARE CLINIC LLC
00715965	C	11/28/2023	MEDICAL	0004	DEP		\$1,000.80	2023-314000701-0000		ST ANTHONY HOSPITAL SSM HEALTH
00715966	C	11/28/2023	MEDICAL	LAB3	DEP		\$9.91	2023-314001484-0000		OKLAHOMA ARTHRITIS CENTER
00715967	C	11/28/2023	MEDICAL	0010	DEP		\$116.64	2023-314001485-0000		OKLAHOMA ARTHRITIS CENTER
00715968	C	11/28/2023	MEDICAL	0010	DEP		\$69.42	2023-317001459-0000		ACCESS ENDOCRINE DIABETES
00715969	C	11/28/2023	MEDICAL	0010	DEP		\$122.34	2023-312000399-0000		OU HEALTH PARTNERS INC
00715970	C	11/28/2023	MEDICAL	0021	DEP		\$4.50	2023-311000715-0000		CHIROPRACTIC ARTS CENTER OF M
00715971	C	11/28/2023	MISC	DIRC	DEP		\$4,395.00	2023-321003789-0000		ATLAS BILLING COMPANY
00715972	C	11/28/2023	MEDICAL	0047	DEP		\$863.88	2023-258000943-0000		OKLAHOMA OTOLARYNGOLOGY ASE
00715973	C	11/28/2023	MEDICAL	XRY2	EMP		\$19.22	2023-313000463-0000		TOUCHSTONE IMAGING OKLAHOMA
00715974	C	11/28/2023	MEDICAL	0011	EMP		\$236.51	2023-318000805-0000		NGA ANESTHESIA PLLC
00715975	C	11/28/2023	MEDICAL	0004	EMP		\$177.82	2023-313000178-0000		NORMAN REGIONAL HOSPITAL
00715976	C	11/28/2023	MEDICAL	0035	EMP		\$88.18	2023-320000866-0000		NRHS RADIOLOGY ASSOCIATES
00715977	C	11/28/2023	MEDICAL	0153	DEP		\$78.30	2023-317001676-0000		CLASSEN URGENT CARE CLINIC LLC
00715978	C	11/28/2023	MEDICAL	0010	DEP		\$61.61	2023-319000624-0000		INTEGRIS MEDICAL GROUP

DAILY CHECK REGISTER

City of Moore (70009)

First Fidelity Bank
 City of Moore (79023)

Check Number	Chk/ EFT	Check Date	Type Expense	Cvg Type	Emp/ Dep	Over Spec	Check Amount	Claim Number	Employee	Payee
00715979	C	11/28/2023	MEDICAL	0010	DEP		\$65.14	2023-319004337-0000		INTEGRIS MEDICAL GROUP
00715980	C	11/28/2023	MEDICAL	0017	DEP		\$65.00	2023-314001345-0000		OPTC COMPLETE REHAB, LLC
00715981	C	11/28/2023	MEDICAL	0017	DEP		\$65.00	2023-314001352-0000		OPTC COMPLETE REHAB, LLC
00715982	C	11/28/2023	MEDICAL	0076	DEP		\$40.00	2023-314001353-0000		OPTC COMPLETE REHAB, LLC
00715983	C	11/28/2023	MEDICAL	0076	DEP		\$65.00	2023-314001354-0000		OPTC COMPLETE REHAB, LLC
00715984	C	11/28/2023	MEDICAL	OT	DEP		\$65.00	2023-314001355-0000		OPTC COMPLETE REHAB, LLC
00715985	C	11/28/2023	MEDICAL	OT	DEP		\$75.00	2023-314007082-0000		OKLAHOMA HCA
00715986	C	11/28/2023	MEDICAL	SPEC	DEP		\$95.00	2023-314007112-0000		OKLAHOMA HCA
00715987	C	11/28/2023	MEDICAL	0333	DEP		\$13.00	2023-318000884-0000		AVEANNA HEALTHCARE MEDICAL SC
00715988	C	11/28/2023	MEDICAL	0333	DEP		\$42.95	2023-318000886-0000		AVEANNA HEALTHCARE MEDICAL SC
00715989	C	11/28/2023	MEDICAL	SUP3	DEP		\$744.00	2023-319000258-0000		AVEANNA HEALTHCARE MEDICAL SC
00715990	C	11/28/2023	MEDICAL	0027	DEP		\$285.76	2023-319000312-0000		EMERGENCY SERVICES OF OKLAHO
00715991	C	11/28/2023	MEDICAL	0010	DEP		\$64.73	2023-319005123-0000		DONNA COSBY
00715992	C	11/28/2023	MEDICAL	0010	DEP		\$35.76	2023-319005285-0000		DONNA COSBY
00715993	C	11/28/2023	MEDICAL	WELL	DEP		\$24.76	2023-319003338-0000		OU MEDICINE INC
00715994	C	11/28/2023	M/N	0020	DEP		\$196.70	2023-317001104-0000		BALANCE WOMEN HEALTH
00715995	C	11/28/2023	M/N	0020	DEP		\$127.66	2023-320001853-0000		BALANCE WOMEN HEALTH
00715996	C	11/28/2023	MEDICAL	0047	DEP		\$598.84	2023-310000543-0000		OU HEALTH PARTNERS INC
00715997	C	11/28/2023	MEDICAL	0010	DEP		\$122.34	2023-317001838-0000		OU HEALTH PARTNERS INC
00715998	C	11/28/2023	MEDICAL	0066	EMP		\$647.36	2023-320000896-0000		ORTHO CENTRAL
00715999	C	11/28/2023	MEDICAL	LAB3	DEP		\$3.00	2023-313000643-0000		ACCESS ENDOCRINE DIABETES
00716000	C	11/28/2023	MEDICAL	0010	DEP		\$111.74	2023-314001338-0000		ACCESS ENDOCRINE DIABETES
00716001	C	11/28/2023	MEDICAL	0035	DEP		\$376.20	2023-314000720-0000		OU MEDICINE INC
00716002	C	11/28/2023	MEDICAL	0187	DEP		\$733.50	2023-292000057-0000		NORMAN ENDOSCOPY CENTER-LLC
00716003	C	11/28/2023	M/N	0020	DEP		\$46.31	2023-313001020-0000		NORMAN UROLOGY ASSOCIATES PC
00716004	C	11/28/2023	MEDICAL	0004	DEP		\$346.50	2023-317000261-0000		NORMAN REGIONAL HOSPITAL

DAILY CHECK REGISTER

City of Moore (70009)

First Fidelity Bank
 City of Moore (79023)

Check Number	Chk/EFT	Check Date	Type Expense	Cvg Type	Emp/Dep	Over Spec	Check Amount	Claim Number	Employee	Payee
00716005	C	11/28/2023	MEDICAL	0010	DEP		\$138.02	2023-320000631-0000		NRHS SURGICAL ASSOCIATES
00716006	C	11/28/2023	MEDICAL	0010	DEP		\$134.50	2023-314001809-0000		BALANCE WOMEN HEALTH
00716007	C	11/28/2023	MEDICAL	0039	EMP		\$156.48	2023-317000771-0000		MERCY CLINIC OKLAHOMA COMMUN
00716008	C	11/28/2023	MEDICAL	0076	DEP		\$36.00	2023-317001284-0000		HOLLAND PEDIATRIC THERAPY
00716009	C	11/28/2023	MEDICAL	ERHS	DEP		\$1,540.35	2023-320000186-0000		NORMAN REGIONAL HOSPITAL
00716010	C	11/28/2023	MEDICAL	0010	DEP		\$59.63	2023-320000298-0000		NORMAN PEDIATRIC ASSOCIATES
00716011	C	11/28/2023	MEDICAL	OT	DEP		\$36.00	2023-320000983-0000		HOLLAND PEDIATRIC THERAPY
00716012	C	11/28/2023	MEDICAL	0076	DEP		\$58.50	2023-320000984-0000		HOLLAND PEDIATRIC THERAPY
00716013	C	11/28/2023	MEDICAL	0153	EMP		\$78.30	2023-317001675-0000		CLASSEN URGENT CARE CLINIC LLC
00716014	C	11/28/2023	MEDICAL	0004	DEP		\$134.15	2023-314000851-0000		OKLAHOMA HEART HOSPITAL
00716015	C	11/28/2023	MEDICAL	0072	DEP		\$1,657.82	2023-314000863-0000		MERCY HOSPITAL OKLAHOMA CITY
00716016	C	11/28/2023	MEDICAL	0004	EMP		\$194.28	2023-257000031-0000		INTEGRIS SOUTHWEST MEDICAL
00716017	C	11/28/2023	MEDICAL	0010	DEP		\$49.89	2023-320001917-0000		WILLIAM BENDURE MD PLLC
00716018	C	11/28/2023	MEDICAL	0004	DEP		\$161.10	2023-314000887-0000		LAKESIDE WOMEN'S CENTER
00716019	C	11/28/2023	MEDICAL	0010	EMP		\$154.89	2023-318000167-0000		NR NORMAN LLC
00716020	C	11/28/2023	MEDICAL	0017	EMP		\$1,496.48	2023-318000169-0000		NR NORMAN LLC
00716021	C	11/28/2023	MEDICAL	0017	EMP		\$1,793.81	2023-318000211-0000		NR NORMAN LLC
00716022	C	11/28/2023	MEDICAL	0068	DEP		\$391.18	2023-318000431-0000		NORMAN PEDIATRIC ASSOCIATES
00716023	C	11/28/2023	MEDICAL	0017	EMP		\$1,766.48	2023-319000119-0000		NR NORMAN LLC
00716024	C	11/28/2023	MEDICAL	0017	EMP		\$1,766.48	2023-3190004826-0000		NR NORMAN LLC
00716025	C	11/28/2023	MEDICAL	0017	EMP		\$1,766.48	2023-319005108-0000		NR NORMAN LLC
00716026	C	11/28/2023	MEDICAL	0017	EMP		\$1,766.48	2023-319005548-0000		NR NORMAN LLC
00716027	C	11/28/2023	MEDICAL	0017	EMP		\$1,766.48	2023-320001294-0000		NR NORMAN LLC
00716028	C	11/28/2023	MEDICAL	0153	DEP		\$78.30	2023-313000830-0000		CLASSEN URGENT CARE CLINIC LLC
00716029	C	11/28/2023	MEDICAL	0010	DEP		\$151.66	2023-314002134-0000		NORMAN UROLOGY ASSOCIATES PC
00716030	C	11/28/2023	MEDICAL	WELL	DEP		\$168.94	2023-319003829-0000		ONECORE HEALTH

DAILY CHECK REGISTER

City of Mooré (70009)

First Fidelity Bank
 City of Moore (79023)

Check Number	Chk/EFT	Check Date	Type Expense	Cvg Type	Emp/Dep	Over Spec	Check Amount	Claim Number	Employee	Payee
00716031	C	11/28/2023	MEDICAL	0010	DEP		\$96.58	2023-319004077-0000		INTEGRIS MEDICAL GROUP
00716032	C	11/28/2023	MEDICAL	0039	DEP		\$95.97	2023-324002610-0000		HARMONY WOMEN'S HEALTHCARE
00716033	C	11/28/2023	MEDICAL	0153	EMP		\$78.30	2023-317001683-0000		CLASSEN URGENT CARE CLINIC LLC
00716034	C	11/28/2023	MEDICAL	0047	EMP		\$399.85	2023-311001677-0000		ORTHOPAEDIC SPORTS MEDICINE C
00716035	C	11/28/2023	MEDICAL	0004	EMP		\$148.94	2023-314000850-0000		OKLAHOMA HEART HOSPITAL
00716036	C	11/28/2023	M/N	0020	DEP		\$225.00	2023-320001213-0000		PSYCHIATRIC HEALTH CORPORATIO
00716037	C	11/28/2023	MEDICAL	0010	DEP		\$60.43	2023-317001034-0000		INTEGRIS MEDICAL GROUP
00716038	C	11/28/2023	MEDICAL	0010	DEP		\$36.65	2023-320001530-0000		OKLAHOMA OTOLARYNGOLOGY ASS
00716039	C	11/28/2023	MEDICAL	0010	EMP		\$139.15	2023-317000942-0000		SOUTHWEST GASTROENTEROLOGY
00716040	C	11/28/2023	MEDICAL	LAB3	EMP		\$22.41	2023-320003601-0000		PRIMARY CARE- WEST MOORE
00716041	C	11/28/2023	MEDICAL	LAB3	EMP		\$22.41	2023-320003621-0000		MOORE MEDICAL CENTER PHYSICIA
00716042	C	11/28/2023	MEDICAL	DXL2	DEP		\$56.47	2023-317001897-0000		CARDIOVASCULAR HEALTH CLINIC I
00716043	C	11/28/2023	MEDICAL	0010	DEP		\$145.98	2023-313000490-0000		ORTHO CENTRAL
00716044	C	11/28/2023	MEDICAL	0047	DEP		\$898.93	2023-297001744-0000		SOUTHWEST ORTHOPAEDIC RECON
00716045	C	11/28/2023	MEDICAL	0011	DEP		\$366.75	2023-312000391-0000		ORTHOMED STAFFING LLC
00716046	C	11/28/2023	MEDICAL	0035	DEP		\$108.65	2023-312000396-0000		ORTHOMED STAFFING LLC
00716047	C	11/28/2023	MEDICAL	0153	DEP		\$78.30	2023-317001677-0000		CLASSEN URGENT CARE CLINIC LLC
00716048	C	11/28/2023	MEDICAL	0010	DEP		\$32.33	2023-317000936-0000		ELITE WELLNESS PLLC SARA BOTCH
00716049	C	11/28/2023	MEDICAL	0047	DEP		\$272.83	2023-264000641-0000		BRANT BENNETT MD PLLC
00716050	C	11/28/2023	MEDICAL	0047	DEP		\$206.14	2023-264000818-0000		BRANT BENNETT MD PLLC
00716051	C	11/28/2023	MEDICAL	0072	DEP		\$829.25	2023-296000656-0000		NORMAN REGIONAL HOSPITAL
00716052	C	11/28/2023	MEDICAL	0072	DEP		\$39.45	2023-297001986-0000		BRANT BENNETT MD PLLC
00716053	C	11/28/2023	MEDICAL	0004	DEP		\$179.46	2023-311000571-0000		NORMAN REGIONAL HOSPITAL
00716054	C	11/28/2023	MEDICAL	0035	DEP		\$100.31	2023-317000969-0000		BRANT BENNETT MD PLLC
00716055	C	11/28/2023	MEDICAL	0010	DEP		\$178.11	2023-318000427-0000		DONALD P MAXWELL JR MD PLLC
00716056	C	11/28/2023	MEDICAL	0153	EMP		\$78.30	2023-320001578-0000		CLASSEN URGENT CARE CLINIC LLC

DAILY CHECK REGISTER

City of Moore (70009)

First Fidelity Bank
 City of Moore (79023)

Check Number	Chk/EFT	Check Date	Type Expense	Cvg Type	Emp/Dep	Over Spec	Check Amount	Claim Number	Employee	Payee
00716057	C	11/28/2023	MEDICAL	0047	DEP		\$1,018.28	2023-311001944-0000		GORDON J BEAN DPM INC
00716058	C	11/28/2023	MEDICAL	0010	DEP		\$60.43	2023-319003486-0000		INTEGRIS MEDICAL GROUP
00716059	C	11/28/2023	MEDICAL	0153	DEP		\$78.30	2023-320001576-0000		CLASSEN URGENT CARE CLINIC LLC
00716060	C	11/28/2023	MEDICAL	0018	DEP		\$189.00	2023-312000529-0000		JACKSON CHIROPRACTIC CLINIC.
00716061	C	11/28/2023	MEDICAL	0177	DEP		\$46.25	2023-313000557-0000		DIAGNOSTIC LABORATORY OF OKLA
00716062	C	11/28/2023	MEDICAL	WELL	DEP		\$59.12	2023-314001434-0000		BREAST CARE SPECIALISTS OF OK
00716063	C	11/28/2023	MEDICAL	WELL	DEP		\$405.00	2023-319003339-0000		OU MEDICINE INC
00716064	C	11/28/2023	MEDICAL	0010	EMP		\$69.42	2023-318000812-0000		RICK R SCHMIDT MD PC
00716065	C	11/28/2023	MEDICAL	0153	EMP		\$78.30	2023-317001664-0000		CLASSEN URGENT CARE CLINIC LLC
00716066	C	11/28/2023	MEDICAL	0153	DEP		\$91.80	2023-317001509-0000		MERCY OKLAHOMA AMBULATORY SE
00716067	C	11/28/2023	MEDICAL	0010	EMP		\$55.15	2023-319003402-0000		INTEGRIS MEDICAL GROUP
00716068	C	11/28/2023	MEDICAL	0073	EMP		\$60.21	2023-319003653-0000		INTEGRIS MEDICAL GROUP
00716069	C	11/28/2023	MEDICAL	0010	DEP		\$116.33	2023-317000981-0000		OU HEALTH PARTNERS INC
00716070	C	11/28/2023	M/N	0020	EMP		\$71.81	2023-317001330-0000		JESSICA SMITH
00716071	C	11/28/2023	MEDICAL	0010	DEP		\$53.37	2023-319000457-0000		DARREN ELENBURG DPM PC
00716072	C	11/28/2023	MEDICAL	0010	DEP		\$41.90	2023-320000669-0000		PREMIERE PEDIATRICS PLLC
00716073	C	11/28/2023	MEDICAL	0010	DEP		\$41.90	2023-320000670-0000		PREMIERE PEDIATRICS PLLC
00716074	C	11/28/2023	MEDICAL	0333	DEP		\$53.16	2023-314001017-0000		ROTECH HEALTH
00716075	C	11/28/2023	MEDICAL	0010	DEP		\$107.01	2023-313001287-0000		BALANCE WOMEN HEALTH
00716076	C	11/28/2023	MEDICAL	0010	DEP		\$82.90	2023-320000446-0000		THE PHYSICIANS GROUP LLC
00716077	C	11/28/2023	MEDICAL	0153	DEP		\$99.00	2023-320000577-0000		IMMEDIATE CARE OF OKLAHOMA LL
00716078	C	11/28/2023	MEDICAL	0072	DEP		\$1,278.90	2023-291000057-0000		INTEGRIS SOUTHWEST MEDICAL
00716079	C	11/28/2023	MEDICAL	0010	DEP		\$139.03	2023-319005187-0000		INTEGRIS MEDICAL GROUP
00716080	C	11/28/2023	MEDICAL	0010	EMP		\$108.20	2023-320001042-0000		JENNIFER B ROBERTS, MD PLLC
00716081	C	11/28/2023	MEDICAL	0010	DEP		\$21.15	2023-314002131-0000		NORMAN PEDIATRIC ASSOCIATES
00716082	C	11/28/2023	MEDICAL	WELL	EMP		\$50.85	2023-313000547-0000		DIAGNOSTIC LABORATORY OF OKLA

DAILY CHECK REGISTER

City of Moore (70009)

First Fidelity Bank
 City of Moore (79023)

Check Number	Chk/ EFT	Check Date	Type Expense	Cvg Type	Emp/ Dep	Over Spec	Check Amount	Claim Number	Employee	Payee
00716083	C	11/28/2023	MEDICAL	0073	EMP		\$47.97	2023-317000918-0000		PHYSICIAN MANAGEMENT SERVICES
00716084	C	11/28/2023	MEDICAL	0177	EMP		\$9.32	2023-320000982-0000		DIAGNOSTIC LABORATORY OF OKLA
00716085	C	11/28/2023	MEDICAL	0153	DEP		\$78.30	2023-313000827-0000		CLASSEN URGENT CARE CLINIC LLC
00716086	C	11/28/2023	MEDICAL	0010	DEP		\$53.24	2023-313000826-0000		CLASSEN FAMILY PRACTICE LLC
00716087	C	11/28/2023	MEDICAL	0153	EMP		\$78.30	2023-317001663-0000		CLASSEN URGENT CARE CLINIC LLC
00716088	C	11/28/2023	MEDICAL	0177	DEP		\$10.52	2023-318000478-0000		DIAGNOSTIC LABORATORY OF OKLA
00716089	C	11/28/2023	MEDICAL	0004	EMP		\$50.00	2023-320000094-0000		OKLAHOMA HEART HOSPITAL SOUTH
00716090	C	11/28/2023	MEDICAL	0010	DEP		\$41.09	2023-320001092-0000		ORTHO CENTRAL
00716091	C	11/28/2023	MEDICAL	0010	EMP		\$71.06	2023-320001458-0000		MERCY CLINIC OKLAHOMA COMMUN
00716092	C	11/28/2023	MEDICAL	WELL	EMP		\$316.61	2023-319003483-0000		INTEGRIS MEDICAL GROUP
00716093	C	11/28/2023	MEDICAL	0068	DEP		\$111.74	2023-314001723-0000		PREMIERE PEDIATRICS PLLC
00716094	C	11/28/2023	MEDICAL	0010	DEP		\$58.21	2023-317001792-0000		KIMBERLY M WISE MD PC
00716095	C	11/28/2023	MEDICAL	WELL	DEP		\$42.26	2023-313000548-0000		DIAGNOSTIC LABORATORY OF OKLA
00716096	C	11/28/2023	MEDICAL	0010	DEP		\$97.76	2023-317001852-0000		INTEGRIS MEDICAL GROUP
00716097	C	11/28/2023	MEDICAL	0076	DEP		\$36.00	2023-317001336-0000		HOLLAND PEDIATRIC THERAPY
00716098	C	11/28/2023	MEDICAL	0076	DEP		\$36.00	2023-318000471-0000		HOLLAND PEDIATRIC THERAPY
00716099	C	11/28/2023	MEDICAL	0153	DEP		\$78.30	2023-320001582-0000		CLASSEN URGENT CARE CLINIC LLC
00716100	C	11/28/2023	MEDICAL	LAB3	DEP		\$43.36	2023-320000812-0000		DIAGNOSTIC LABORATORY OF OKLA
00716101	C	11/28/2023	MEDICAL	0010	EMP		\$76.89	2023-320001926-0000		DEAN MC GEE EYE INSTITUTE
00716102	C	11/28/2023	MISC	DIRC	DEP		\$225.00	2023-321003791-0000		ATLAS BILLING COMPANY
00716103	C	11/28/2023	MEDICAL	0153	DEP		\$78.30	2023-311001137-0000		CLASSEN URGENT CARE CLINIC LLC
00716104	C	11/28/2023	MEDICAL	0010	DEP		\$20.05	2023-314001149-0000		SAINTS MEDICAL GROUP LLC
00716105	C	11/28/2023	MEDICAL	0010	DEP		\$248.50	2023-312000489-0000		ORTHO CENTRAL
00716106	C	11/28/2023	MEDICAL	0010	DEP		\$41.09	2023-317001277-0000		ORTHO CENTRAL
00716107	C	11/28/2023	MEDICAL	0047	DEP		\$108.86	2023-320001115-0000		ORTHO CENTRAL
00716108	C	11/28/2023	MEDICAL	0010	DEP		\$144.05	2023-319003279-0000		INTEGRIS MEDICAL GROUP

DAILY CHECK REGISTER

City of Moore (7009)

First Fidelity Bank
 City of Moore (79023)

Check Number	Chk/ EFT	Check Date	Type Expense	Cvg Type	Emp/ Dep	Over Spec	Check Amount	Claim Number	Employee	Payee
00716109	C	11/28/2023	MEDICAL	0153	DEP		\$78.30	2023-313000831-0000		CLASSEN URGENT CARE CLINIC LLC
00716110	C	11/28/2023	MEDICAL	0017	DEP		\$161.10	2023-314000762-0000		INTEGRIS BAPTIST MEDICAL CENTE
00716111	C	11/28/2023	MEDICAL	0017	EMP		\$10.80	2023-320000589-0000		ORTHOPEDIC SPINE AND SPORTS PI
00716112	C	11/28/2023	M/N	0020	DEP		\$71.81	2023-320000363-0000		RESTORE BEHAVIORAL HEALTH LLC
00716113	C	11/28/2023	MEDICAL	0177	EMP		\$32.11	2023-313000560-0000		DIAGNOSTIC LABORATORY OF OKLA
00716114	C	11/28/2023	MEDICAL	0010	EMP		\$39.10	2023-313000709-0000		OKLAHOMA CITY VAMC
00716115	C	11/28/2023	MEDICAL	0035	EMP		\$459.63	2023-314000864-0000		OKLAHOMA CITY VAMC
00716116	C	11/28/2023	MEDICAL	0035	EMP		\$73.41	2023-314000920-0000		OKLAHOMA CITY VAMC
00716117	C	11/28/2023	M/N	0020	DEP		\$71.81	2023-312000961-0000		LINDSEY DEAL
00716118	C	11/28/2023	M/N	0020	DEP		\$71.81	2023-318000081-0000		LINDSEY DEAL
00716119	C	11/28/2023	MEDICAL	0177	DEP		\$24.64	2023-317000429-0000		DIAGNOSTIC LABORATORY OF OKLA
00716120	C	11/28/2023	MEDICAL	0333	EMP		\$58.76	2023-312000934-0000		NORMAN REGIONAL HOSPITAL AUTI
00716121	C	11/28/2023	MEDICAL	DXL2	EMP		\$6.93	2023-317000632-0000		PHYSICIAN HOUSECALLS LLC
00716122	C	11/28/2023	MEDICAL	0333	EMP		\$334.52	2023-313001295-0000		INTEGRIS MEDICAL SUPPLY
00716123	C	11/28/2023	MEDICAL	0010	DEP		\$91.79	2023-318000598-0000		MARIE J CARTER DO
00716124	C	11/28/2023	MEDICAL	0010	EMP		\$60.43	2023-319004140-0000		INTEGRIS MEDICAL GROUP
00716125	C	11/28/2023	MEDICAL	0010	EMP		\$94.64	2023-319003916-0000		INTEGRIS MEDICAL GROUP
00716126	C	11/28/2023	MEDICAL	0153	EMP		\$34.41	2023-317000633-0000		MEDICAL RESOURCE MANAGEMENT
00716127	C	11/28/2023	MEDICAL	0010	EMP		\$57.01	2023-320001065-0000		CARLEY MCLAUGHLIN APRN CNP PLI
00716128	C	11/28/2023	MEDICAL	0153	DEP		\$78.30	2023-313000825-0000		CLASSEN URGENT CARE CLINIC LLC
00716129	C	11/28/2023	MEDICAL	0010	EMP		\$55.33	2023-313001177-0000		BALANCE HORMONE OKLAHOMA PLI
00716130	C	11/28/2023	MEDICAL	0073	DEP		\$36.75	2023-314002132-0000		NORMAN PEDIATRIC ASSOCIATES
00716131	C	11/28/2023	MEDICAL	0073	DEP		\$32.95	2023-314002133-0000		NORMAN PEDIATRIC ASSOCIATES
00716132	C	11/28/2023	MEDICAL	0013	EMP		\$90.70	2023-317000870-0000		LABORATORY CORPORATION OF AP
00716133	C	11/28/2023	MEDICAL	0177	EMP		\$311.74	2023-318000312-0000		OKLAHOMA CITY VAMC
00716134	C	11/28/2023	MEDICAL	0017	EMP		\$49.50	2023-318000411-0000		THERAPY IN MOTION OF OKLAHOM/

DAILY CHECK REGISTER

City of Moore (70009)

First Fidelity Bank
 City of Moore (79023)

Check Number	Chk/ EFT	Check Date	Type Expense	Cvg Type	Emp/ Dep	Over Spec	Check Amount	Claim Number	Employee	Payee
00716135	C	11/28/2023	MEDICAL	0010	DEP		\$61.16	2023-320001541-0000		RONALD R HOPKINS DO PLLC
00716136	C	11/28/2023	MEDICAL	0010	EMP		\$67.61	2023-320001542-0000		RONALD R HOPKINS DO PLLC
00716137	C	11/28/2023	MEDICAL	WELL	DEP		\$145.95	2023-320001954-0000		LABORATORY CORPORATION OF AM
00716138	C	11/28/2023	MEDICAL	0010	EMP		\$97.76	2023-317001949-0000		INTEGRIS MEDICAL GROUP
00716139	C	11/28/2023	MEDICAL	WELL	EMP		\$133.62	2023-319004092-0000		INTEGRIS MEDICAL GROUP
00716140	C	11/28/2023	MEDICAL	0010	EMP		\$139.03	2023-319004318-0000		INTEGRIS MEDICAL GROUP
00716141	C	11/28/2023	MEDICAL	0010	EMP		\$115.65	2023-320000965-0000		NORMAN CARDIOVASCULAR SURGE
00716142	C	11/28/2023	MEDICAL	0010	EMP		\$70.84	2023-314002171-0000		SUMMIT HEALTH AND WELLNESS CEI
00716143	C	11/28/2023	MEDICAL	0073	DEP		\$50.05	2023-317001383-0000		EDMOND PEDIATRICS
00716144	C	11/28/2023	MEDICAL	0018	DEP		\$40.50	2023-319000099-0000		VIBRANT SOL CHIROPRACTIC
00716145	C	11/28/2023	MEDICAL	0010	DEP		\$41.26	2023-314001978-0000		HOMETOWN HEALTHCARE
00716146	C	11/28/2023	MEDICAL	0010	EMP		\$66.75	2023-319000112-0000		HOMETOWN HEALTHCARE
00716147	C	11/28/2023	MEDICAL	0010	DEP		\$189.01	2023-313001009-0000		HEALTHCARE EXPRESS LLP
00716148	C	11/28/2023	MEDICAL	0080	DEP		\$63.94	2023-312000914-0000		OKLAHOMA ALLERGY AND ASTHMA C
00716149	C	11/28/2023	MEDICAL	0177	EMP		\$20.76	2023-313000545-0000		DIAGNOSTIC LABORATORY OF OKLA
00716150	C	11/28/2023	MEDICAL	0010	EMP		\$122.98	2023-312000488-0000		NEUROSCIENCE SPECIALISTS PC
00716151	C	11/28/2023	MEDICAL	0080	DEP		\$127.87	2023-312000917-0000		OKLAHOMA ALLERGY AND ASTHMA C
00716152	C	11/28/2023	MEDICAL	0010	EMP		\$98.12	2023-317001648-0000		LUMINARY DERMATOLOGY OF OKLA
00716153	C	11/28/2023	MEDICAL	0039	DEP		\$238.35	2023-319003908-0000		INTEGRIS MEDICAL GROUP
00716154	C	11/28/2023	MEDICAL	WELL	EMP		\$3.00	2023-319004278-0000		INTEGRIS MEDICAL GROUP
00716155	C	11/28/2023	MEDICAL	0153	EMP		\$23.40	2023-314000907-0000		CLASSEN URGENT CARE CLINIC LLC
00716156	C	11/28/2023	MEDICAL	0010	EMP		\$97.76	2023-317000987-0000		INTEGRIS MEDICAL GROUP
00716157	C	11/28/2023	MEDICAL	0010	DEP		\$150.18	2023-313000633-0000		CENTRAL OKLAHOMA AMER IND
00716158	C	11/28/2023	MEDICAL	0010	DEP		\$48.68	2023-317000349-0000		CENTRAL OKLAHOMA AMER IND
00716159	C	11/28/2023	MEDICAL	0080	DEP		\$7.79	2023-318000349-0000		OKLAHOMA ALLERGY AND ASTHMA C
00716160	C	11/28/2023	MEDICAL	0010	EMP		\$46.74	2023-320000968-0000		OKLAHOMA WOUND CARE

DAILY CHECK REGISTER

City of Moore (70009)

First Fidelity Bank
 City of Moore (79023)

Check Number	Chk/EFT	Check Date	Type Expense	Cvg Type	Emp/Dep	Over Spec	Check Amount	Claim Number	Employee	Payee
00716161	C	11/28/2023	MEDICAL	0076	DEP		\$36.00	2023-317001282-0000		HOLLAND PEDIATRIC THERAPY
00716162	C	11/28/2023	MEDICAL	0076	DEP		\$36.00	2023-320000985-0000		HOLLAND PEDIATRIC THERAPY
00716163	C	11/28/2023	MEDICAL	0010	DEP		\$138.02	2023-321003741-0000		PRIMARY CARE- SOUTH OKC
00716164	C	11/28/2023	MEDICAL	0010	DEP		\$138.02	2023-321004135-0000		MOORE MEDICAL CENTER PHYSICIA
00716165	C	11/28/2023	MEDICAL	0080	DEP		\$7.79	2023-312000916-0000		OKLAHOMA ALLERGY AND ASTHMA (
00716166	C	11/28/2023	MEDICAL	LAB3	EMP		\$424.48	2023-320000299-0000		PATHOLOGY LAB ASSOCIATES
00716167	C	11/28/2023	MEDICAL	0073	DEP		\$49.52	2023-320000630-0000		MOORE MEDICAL CENTER PHYSICIA
00716168	C	11/28/2023	MEDICAL	0010	DEP		\$90.64	2023-320000966-0000		MOORE MEDICAL CENTER PHYSICIA
00716169	C	11/28/2023	MEDICAL	0010	DEP		\$34.49	2023-319003482-0000		INTEGRIS MEDICAL GROUP
00716170	C	11/28/2023	MEDICAL	0010	EMP		\$34.49	2023-319004074-0000		INTEGRIS MEDICAL GROUP
00716171	C	11/28/2023	MEDICAL	0010	DEP		\$65.14	2023-319004303-0000		INTEGRIS MEDICAL GROUP
00716172	C	11/28/2023	M/N	0020	DEP		\$71.81	2023-320001794-0000		JESSICA CAUDLE
00716173	C	11/28/2023	MEDICAL	0010	DEP		\$83.84	2023-313000786-0000		SAINTS MEDICAL GROUP LLC
00716174	C	11/28/2023	MEDICAL	0010	DEP		\$56.99	2023-320001411-0000		SAINTS MEDICAL GROUP LLC
00716175	C	11/28/2023	MEDICAL	WELL	DEP		\$168.00	2023-313000179-0000		NORMAN REGIONAL HOSPITAL
00716176	C	11/28/2023	MEDICAL	0047	EMP		\$552.01	2023-313000519-0000		OCULAR PHYSICIANS ASSOCIATES I
00716177	C	11/28/2023	MEDICAL	WELL	DEP		\$79.21	2023-313001063-0000		NRHS RADIOLOGY ASSOCIATES
00716178	C	11/28/2023	MEDICAL	0013	DEP		\$50.09	2023-317001526-0000		DIAGNOSTIC PATHOLOGY SERVICES
00716179	C	11/28/2023	MEDICAL	WELL	DEP		\$128.64	2023-320000830-0000		DIAGNOSTIC LABORATORY OF OKLA
00716180	C	11/28/2023	MISC	DIRC	EMP		\$5,765.00	2023-321003788-0000		ATLAS BILLING COMPANY
00716181	C	11/28/2023	MEDICAL	0010	DEP		\$35.76	2023-317000856-0000		OK FOOT AND ANKLE SPECIALISTS
00716182	C	11/28/2023	MEDICAL	0177	DEP		\$7.96	2023-313000553-0000		DIAGNOSTIC LABORATORY OF OKLA
00716183	C	11/28/2023	MEDICAL	0177	EMP		\$42.32	2023-313000556-0000		DIAGNOSTIC LABORATORY OF OKLA
00716184	C	11/28/2023	MEDICAL	0010	DEP		\$81.59	2023-317001645-0000		TOTAL HEALTHCARE PARTNERS
00716185	C	11/28/2023	MEDICAL	0039	DEP		\$134.71	2023-317001888-0000		OKLAHOMA CITY GYNECOLOGY & OI
00716186	C	11/28/2023	MEDICAL	LAB3	DEP		\$87.44	2023-319000640-0000		ROBERT REYNOLDS MD PC

DAILY CHECK REGISTER

City of Moore (70009)

First Fidelity Bank
 City of Moore (79023)

Check Number	Chk/ EFT	Check Date	Type Expense	Cvg Type	Emp/ Dep	Over Spec	Check Amount	Claim Number	Employee	Payee
00716187	C	11/28/2023	MEDICAL	0039	EMP		\$157.59	2023-319000621-0000		INTEGRIS MEDICAL GROUP
00716188	C	11/28/2023	MEDICAL	SUR3	EMP		\$302.53	2023-320001766-0000		DERMATOLOGY AND COSMETIC CEN
00716189	C	11/28/2023	MEDICAL	0010	EMP		\$344.70	2023-313001017-0000		FOREFRONT DERMATOLOGY
00716190	C	11/28/2023	MEDICAL	0010	EMP		\$140.91	2023-319000487-0000		SAINTS MEDICAL GROUP LLC
00716191	C	11/28/2023	MEDICAL	0010	DEP		\$24.00	2023-311001452-0000		YOUNG CHIROPRACTIC PC
00716192	C	11/28/2023	M/N	0020	DEP		\$71.81	2023-317001385-0000		AMANDA BRANDON
00716193	C	11/28/2023	MEDICAL	0018	DEP		\$120.00	2023-318000944-0000		YOUNG CHIROPRACTIC PC
00716194	C	11/28/2023	MEDICAL	0153	DEP		\$78.30	2023-320001575-0000		CLASSEN URGENT CARE CLINIC LLC
00716195	C	11/28/2023	MEDICAL	0012	EMP		\$42.33	2023-311000688-0000		EAGLE PARTNERS PLLC
00716196	C	11/28/2023	MEDICAL	0017	EMP		\$36.00	2023-317000755-0000		YUKON WOUND CARE REHAB PLLC
00716197	C	11/28/2023	MEDICAL	0017	EMP		\$36.00	2023-319000772-0000		YUKON WOUND CARE REHAB PLLC
00716198	C	11/28/2023	MEDICAL	0010	EMP		\$101.43	2023-319004858-0000		INTEGRIS MEDICAL GROUP
00716199	C	11/28/2023	MEDICAL	0153	EMP		\$78.30	2023-317001651-0000		CLASSEN URGENT CARE CLINIC LLC
00716200	C	11/28/2023	MEDICAL	0021	DEP		\$531.08	2023-314002165-0000		MOORE MEDICAL CENTER PHYSICIA
00716201	C	11/28/2023	MEDICAL	0076	DEP		\$36.00	2023-318000442-0000		ALEXANDRA ROY
00716202	C	11/28/2023	MEDICAL	0076	DEP		\$36.00	2023-319004079-0000		ALEXANDRA ROY
00716203	C	11/28/2023	MEDICAL	0076	DEP		\$36.00	2023-319004268-0000		ALEXANDRA ROY
00716204	C	11/28/2023	MEDICAL	0076	DEP		\$36.00	2023-319004857-0000		ALLISON DEIMUND
00716205	C	11/28/2023	MEDICAL	0076	DEP		\$36.00	2023-319004901-0000		ALEXANDRA ROY
00716206	C	11/28/2023	MEDICAL	0076	DEP		\$36.00	2023-319005107-0000		ALEXANDRA ROY
00716207	C	11/28/2023	MEDICAL	0076	DEP		\$36.00	2023-319005199-0000		ALEXANDRA ROY
00716208	C	11/28/2023	MEDICAL	0076	DEP		\$36.00	2023-319005325-0000		ALEXANDRA ROY
00716209	C	11/28/2023	MEDICAL	0153	DEP		\$30.60	2023-313000206-0000		CLASSEN URGENT CARE CLINIC LLC
00716210	C	11/28/2023	MEDICAL	0177	DEP		\$285.53	2023-320000408-0000		LABORATORY CORPORATION OF AI
00716211	C	11/28/2023	MEDICAL	WELL	EMP		\$9.19	2023-305003942-0000		DIAGNOSTIC LABORATORY OF OKLA
00716212	C	11/28/2023	MEDICAL	WELL	DEP		\$55.64	2023-317001279-0000		MATTISON PATHOLOGY LLP DBA AVI

DAILY CHECK REGISTER

City of Moore (70009)

First Fidelity Bank
 City of Moore (79023)

Check Number	Chk/ EFT	Check Date	Type Expense	Cvg Type	Emp/ Dep	Over Spec	Check Amount	Claim Number	Employee	Payee
00716213	C	11/28/2023	MEDICAL	0019	EMP		\$63.00	2023-317001531-0000		BROOKWOOD CHIROPRACTIC
00716214	C	11/28/2023	MEDICAL	0010	DEP		\$222.95	2023-311000951-0000		MERCY CLINIC OKLAHOMA COMMUN
00716215	C	11/28/2023	MEDICAL	0153	DEP		\$56.00	2023-317000638-0000		MEDICAL RESOURCE MANAGEMENT
00716216	C	11/28/2023	MEDICAL	0010	DEP		\$97.76	2023-319003895-0000		INTEGRIS MEDICAL GROUP
00716217	C	11/28/2023	MEDICAL	WELL	EMP		\$133.62	2023-319004778-0000		INTEGRIS MEDICAL GROUP
00716218	C	11/28/2023	MEDICAL	WELL	EMP		\$3.00	2023-319004926-0000		INTEGRIS MEDICAL GROUP
00716219	C	11/28/2023	MEDICAL	0017	DEP		\$36.00	2023-320000592-0000		ORTHOPEDIC SPINE AND SPORTS PI
00716220	C	11/28/2023	MEDICAL	0017	DEP		\$36.00	2023-320000594-0000		ORTHOPEDIC SPINE AND SPORTS PI
00716221	C	11/28/2023	MEDICAL	0153	DEP		\$78.30	2023-313000836-0000		CLASSEN URGENT CARE CLINIC LLC
00716222	C	11/28/2023	MEDICAL	0010	DEP		\$59.46	2023-314002049-0000		DIGESTIVE DISEASE SPECIALISTS
00716223	C	11/28/2023	MEDICAL	0010	EMP		\$83.84	2023-319000486-0000		SAINTS MEDICAL GROUP LLC
00716224	C	11/28/2023	MEDICAL	0010	EMP		\$86.62	2023-324002599-0000		OKLAHOMA MEDICAL PAIN MANAGE
00716225	C	11/28/2023	MEDICAL	0010	EMP		\$60.43	2023-319004922-0000		INTEGRIS MEDICAL GROUP
00716226	C	11/28/2023	MEDICAL	0066	DEP		\$95.82	2023-291000219-0000		EAGLE PARTNERS PLLC
00716227	C	11/28/2023	MEDICAL	0004	EMP		\$110.14	2023-313000157-0000		MERCY HOSPITAL OKLAHOMA CITY
00716228	C	11/28/2023	MEDICAL	WELL	DEP		\$405.00	2023-320000217-0000		OU MEDICINE INC
00716229	C	11/28/2023	MEDICAL	0010	EMP		\$166.40	2023-319003282-0000		INTEGRIS MEDICAL GROUP
00716230	C	11/28/2023	MEDICAL	0010	EMP		\$97.76	2023-319004075-0000		INTEGRIS MEDICAL GROUP
00716231	C	11/28/2023	MEDICAL	0153	EMP		\$78.30	2023-313000829-0000		CLASSEN URGENT CARE CLINIC LLC
00716232	C	11/28/2023	MEDICAL	0010	DEP		\$87.31	2023-317001547-0000		MERCY CLINIC OKLAHOMA COMMUN
00716233	C	11/28/2023	M/N	0020	DEP		\$71.81	2023-320000574-0000		TANNER UNDERWOOD
00716234	C	11/28/2023	MEDICAL	0177	EMP		\$32.37	2023-317001290-0000		DIAGNOSTIC LABORATORY OF OKLA

308 CHECKS PAID AMOUNTING TO \$63,761.00 ✓
 308 PAYMENTS AMOUNTING TO \$63,761.00

ELECTRONIC PAYMENTS AMOUNTING TO \$0.00

0 TOTAL ADJUSTMENTS FOR \$0.00

DAILY CHECK REGISTER

0

First Fidelity Bank

0

Check Number	Chk/ EFT	Check Date	Type Expense	Cvg Type	Emp/ Dep	Over Spec	Check Amount	Claim Number	Employee	Payee
<u>BREAKDOWN</u>			<u>Medical</u>	<u>Dental</u>	<u>Vision</u>	<u>Drug</u>	<u>Other</u>	<u>Excess</u>		
CHECKS			293	0	0	0	15	0		
TOTALS			\$52,174.41	\$0.00	\$0.00	\$0.00	\$11,586.59	\$0.00		

DAILY CHECK REGISTER

City of Moore (70009)

First Fidelity Bank
 City of Moore (79024)

Check Number	Chk/ EFT	Check Date	Type Expense	Cvg Type	Emp/ Dep	Over Spec	Check Amount	Claim Number	Employee	Payee
00716235	C	11/28/2023	MEDICAL	0153	EMP		\$12.80	2023-314000906-0000		CLASSEN URGENT CARE CLINIC.LLC
00716236	C	11/28/2023	MEDICAL	0153	DEP		\$61.60	2023-313000832-0000		CLASSEN URGENT CARE CLINIC LLC
00716237	C	11/28/2023	MEDICAL	0010	DEP		\$35.41	2023-320000667-0000		PREMIERE PEDIATRICS PLLC
00716238	C	11/28/2023	MEDICAL	0153	EMP		\$61.60	2023-317001685-0000		CLASSEN URGENT CARE CLINIC.LLC
00716239	C	11/28/2023	MEDICAL	0068	DEP		\$688.67	2023-320001457-0000		MERCY CLINIC OKLAHOMA COMMUN
00716240	C	11/28/2023	MEDICAL	0039	DEP		\$166.45	2023-319003654-0000		INTEGRIS MEDICAL GROUP
00716241	C	11/28/2023	MEDICAL	0153	EMP		\$61.60	2023-317001684-0000		CLASSEN URGENT CARE CLINIC LLC
00716242	C	11/28/2023	MEDICAL	0153	EMP		\$61.60	2023-320001581-0000		CLASSEN URGENT CARE CLINIC LLC
00716243	C	11/28/2023	MEDICAL	0153	EMP		\$61.60	2023-313000821-0000		CLASSEN URGENT CARE CLINIC LLC

9 CHECKS PAID AMOUNTING TO \$1,211.33 ✓
 9 PAYMENTS AMOUNTING TO \$1,211.33

ELECTRONIC PAYMENTS AMOUNTING TO \$0.00

0 TOTAL ADJUSTMENTS FOR \$0.00

BREAKDOWN	Medical	Dental	Vision	Drug	Other	Excess
CHECKS	9	0	0	0	0	0
TOTALS	\$1,211.33	\$0.00	\$0.00	\$0.00	\$0.00	\$0.00

DAILY CHECK REGISTER

City of Moore (70009)

First Fidelity Bank
City of Moore (79025)

Check Number	Chk/EFT	Check Date	Type Expense	Cvg Type	Emp/Dep	Over Spec	Check Amount	Claim Number	Employee	Payee
00716244	C	11/28/2023	MEDICAL	0153	EMP		\$152.93	2023-312000461-0000		FIRST MED URGENT CARE LLC
			1 CHECKS PAID AMOUNTING TO \$152.93 ✓				ELECTRONIC PAYMENTS AMOUNTING TO \$0.00			
			1 PAYMENTS AMOUNTING TO \$152.93				0 TOTAL ADJUSTMENTS FOR \$0.00			

BREAKDOWN	Medical	Dental	Vision	Drug	Other	Excess
CHECKS	1	0	0	0	0	0
TOTALS	\$152.93	\$0.00	\$0.00	\$0.00	\$0.00	\$0.00

DAILY CHECK REGISTER

First Fidelity Bank
 City of Moore (70009)

Check Number	Chk/EFT	Check Date	Type Expense	Cvg Type	Emp/Dep	Over Spec	Check Amount	Claim Number	Employee	Payee
00716245	C	11/28/2023	EXPENSE	EX22	EMP		\$18,388.87	2023-317002462-0000		DELTA DENTAL OF OKLAHOMA
00716246	C	11/28/2023	EXPENSE	EX22	EMP		\$1,974.50	2023-317002484-0000		TELADOC INC
00716247	C	11/28/2023	EXPENSE	EX22	EMP		\$1,996.50	2023-317002485-0000		TELADOC INC
00716248	C	11/28/2023	EXPENSE	EX22	EMP		\$1,991.00	2023-317002486-0000		TELADOC INC

4 CHECKS PAID AMOUNTING TO \$24,350.87 ✓
 4 PAYMENTS AMOUNTING TO \$24,350.87

ELECTRONIC PAYMENTS AMOUNTING TO \$0.00

0 TOTAL ADJUSTMENTS FOR \$0.00

BREAKDOWN	Medical	Dental	Vision	Drug	Other	Excess
CHECKS	0	0	0	0	4	0
TOTALS	\$0.00	\$0.00	\$0.00	\$0.00	\$24,350.87	\$0.00

DAILY CHECK REGISTER

City of Moore (70009)

First Fidelity Bank
 City of Moore (79023)

Check Number	Chk/ EFT	Check Date	Type Expense	Cvg Type	Emp/ Dep	Over Spec	Check Amount	Claim Number	Employee	Payee
00716249	C	11/28/2023	MEDICAL	0039	EMP		\$158.40	2023-279000990-0000		JERAMIAH WALKER APRN CNP PLL
00716250	C	11/28/2023	MEDICAL	WELL	EMP		\$117.22	2023-286001099-0000		CLINICAL PATHOLOGY LABS INC
00716251	C	11/28/2023	MEDICAL	WELL	EMP		\$212.78	2023-310001617-0000		HPI PHYSICIANS LLC
00716252	C	11/28/2023	MEDICAL	0018	EMP		\$81.00	2023-306000788-0000		SPARKS CLINIC
00716253	C	11/28/2023	MEDICAL	0018	EMP		\$103.50	2023-311001738-0000		SPARKS CLINIC
00716254	C	11/28/2023	MEDICAL	0333	EMP		\$241.23	2023-310000759-0000		NORMAN REGIONAL HOSPITAL AUTI
00716255	C	11/28/2023	MEDICAL	0017	DEP		\$49.50	2023-310001843-0000		THERAPY IN MOTION OF OKLAHOMA
00716256	C	11/28/2023	MEDICAL	ERHS	DEP		\$1,389.60	2023-228000278-0000		NORMAN REGIONAL HOSPITAL
00716257	C	11/28/2023	MEDICAL	0177	DEP		\$16.35	2023-268001600-0000		DIAGNOSTIC LABORATORY OF OKLA
00716258	C	11/28/2023	MEDICAL	0177	DEP		\$27.43	2023-289002478-0000		DIAGNOSTIC LABORATORY OF OKLA
00716259	C	11/28/2023	MEDICAL	0177	DEP		\$9.98	2023-299001486-0000		DIAGNOSTIC LABORATORY OF OKLA
00716260	C	11/28/2023	MEDICAL	0177	DEP		\$65.04	2023-299001487-0000		DIAGNOSTIC LABORATORY OF OKLA
00716261	C	11/28/2023	MEDICAL	0177	DEP		\$207.29	2023-299001489-0000		DIAGNOSTIC LABORATORY OF OKLA
00716262	C	11/28/2023	MEDICAL	0010	DEP		\$103.29	2023-285001030-0000		BODIN CHIROPRACTIC PLLC
00716263	C	11/28/2023	MEDICAL	0018	DEP		\$186.60	2023-291001082-0000		BODIN CHIROPRACTIC PLLC
00716264	C	11/28/2023	MEDICAL	0018	DEP		\$83.30	2023-305003159-0000		BODIN CHIROPRACTIC PLLC
00716265	C	11/28/2023	MEDICAL	0010	DEP		\$70.99	2023-311001930-0000		GORDON J BEAN DPM INC
00716266	C	11/28/2023	M/N	0020	DEP		\$71.81	2023-311001315-0000		ASSESSMENT INC
00716267	C	11/28/2023	MEDICAL	0012	EMP		\$8.87	2023-256000663-0000		NRHS RADIOLOGY ASSOCIATES
00716268	C	11/28/2023	MEDICAL	0004	EMP		\$108.89	2023-262000337-0000		NORMAN REGIONAL PROVIDERS SPI
00716269	C	11/28/2023	MEDICAL	0066	EMP		\$64.35	2023-262000464-0000		NRHS RADIOLOGY ASSOCIATES
00716270	C	11/28/2023	MEDICAL	ERHS	EMP		\$1,302.62	2023-264000156-0000		NORMAN REGIONAL HOSPITAL
00716271	C	11/28/2023	MEDICAL	0010	EMP		\$50.70	2023-283000531-0000		JESSICA BOSSART (E)
00716272	C	11/28/2023	MEDICAL	0009	EMP		\$104.96	2023-286000607-0000		NORMAN REGIONAL PROVIDERS SPI
00716273	C	11/28/2023	MEDICAL	0066	EMP		\$97.47	2023-297000351-0000		NORMAN NEUROSCIENCE PHYSICIA
00716274	C	11/28/2023	MEDICAL	0010	DEP		\$32.33	2023-310000562-0000		SOUTHWEST ORTHOPAEDIC RECON

DAILY CHECK REGISTER

City of Moore (70009)

First Fidelity Bank
 City of Moore (79023)

Check Number	Chk/ EFT	Check Date	Type Expense	Cvg Type	Emp/ Dep	Over Spec	Check Amount	Claim Number	Employee	Payee
00716275	C	11/28/2023	MEDICAL	0004	DEP		\$243.58	2023-311000413-0000		NORMAN REGIONAL HOSPITAL
00716276	C	11/28/2023	MEDICAL	0004	DEP		\$711.83	2023-311000414-0000		NORMAN REGIONAL HOSPITAL
00716277	C	11/28/2023	MEDICAL	WELL	DEP		\$8.58	2023-251000289-0000		LABORATORY CORPORATION OF AM
00716278	C	11/28/2023	MEDICAL	0039	DEP		\$123.19	2023-313001525-0000		OKLAHOMA CITY GYNECOLOGY & OI
00716279	C	11/28/2023	MEDICAL	0177	EMP		\$41.55	2023-279000816-0000		DIAGNOSTIC LABORATORY OF OKLA
00716280	C	11/28/2023	MEDICAL	0153	DEP		\$80.66	2023-311001134-0000		CLASSEN URGENT CARE CLINIC LLC
00716281	C	11/28/2023	MEDICAL	0012	EMP		\$9.86	2023-275000977-0000		NRHS RADIOLOGY ASSOCIATES
00716282	C	11/28/2023	MEDICAL	0035	EMP		\$130.54	2023-283000376-0000		NRHS PHYSICIAN OFFICE NETWORK
00716283	C	11/28/2023	MEDICAL	0021	EMP		\$102.43	2023-310001856-0000		ORTHO CENTRAL
00716284	C	11/28/2023	MEDICAL	0010	EMP		\$115.65	2023-311001494-0000		NRHS SURGICAL ASSOCIATES
00716285	C	11/28/2023	MEDICAL	WELL	EMP		\$58.78	2023-310000491-0000		CLASSEN FAMILY PRACTICE LLC
00716286	C	11/28/2023	MEDICAL	0010	EMP		\$196.70	2023-311001035-0000		BALANCE WOMEN HEALTH
00716287	C	11/28/2023	MEDICAL	WELL	EMP		\$34.65	2023-282000582-0000		QUEST DIAGNOSTICS LENEXA
00716288	C	11/28/2023	MEDICAL	0010	EMP		\$55.33	2023-310001485-0000		BALANCE HORMONE OKLAHOMA PLI
00716289	C	11/28/2023	MEDICAL	0177	EMP		\$412.18	2023-262000576-0000		EXACT SCIENCES LABORATORIES
00716290	C	11/28/2023	MEDICAL	0177	DEP		\$6.77	2023-268001955-0000		QUEST DIAGNOSTICS ATLANTA
00716291	C	11/28/2023	MEDICAL	WELL	DEP		\$21.78	2023-268001956-0000		QUEST DIAGNOSTICS ATLANTA
00716292	C	11/28/2023	MEDICAL	0177	EMP		\$6.77	2023-275001355-0000		QUEST DIAGNOSTICS LENEXA
00716293	C	11/28/2023	MEDICAL	WELL	EMP		\$72.72	2023-275002630-0000		QUEST DIAGNOSTICS LENEXA
00716294	C	11/28/2023	MEDICAL	0066	DEP		\$27.20	2023-296001003-0000		OU HEALTH PARTNERS INC.
00716295	C	11/28/2023	MEDICAL	0004	DEP		\$12.69	2023-296001566-0000		SAINTS MEDICAL GROUP LLC
00716296	C	11/28/2023	MEDICAL	LAB3	EMP		\$2.70	2023-314001580-0000		MERCY CLINIC OKLAHOMA COMMUN
00716297	C	11/28/2023	MEDICAL	0177	DEP		\$5.15	2023-285000731-0000		LABORATORY CORPORATION OF AM
00716298	C	11/28/2023	MEDICAL	0035	EMP		\$21.96	2023-297000119-0000		NORMAN REGIONAL HOSPITAL
00716299	C	11/28/2023	MEDICAL	0010	EMP		\$143.55	2023-311000763-0000		ORTHO CENTRAL
00716300	C	11/28/2023	MEDICAL	WELL	EMP		\$301.00	2023-314001332-0000		NORMAN ENDOSCOPY CENTER LLC

DAILY CHECK REGISTER

City of Moore (70009)

First Fidelity Bank
 City of Moore (79023)

Check Number	Chk/EFT	Check Date	Type Expense	Cvg Type	Emp/Dep	Over Spec	Check Amount	Claim Number	Employee	Payee
00716301	C	11/28/2023	MEDICAL	0066	EMP		\$10.58	2023-298000032-0000		EAGLE PARTNERS PLLC
00716302	C	11/28/2023	MEDICAL	0177	EMP		\$142.18	2023-282001973-0000		EXACT SCIENCES LABORATORIES
00716303	C	11/28/2023	MEDICAL	0010	DEP		\$159.46	2023-310000708-0000		INTEGRIS MEDICAL GROUP
00716304	C	11/28/2023	MEDICAL	0003	DEP		\$71,596.74	2023-240000279-0000		INTEGRIS BAPTIST MEDICAL
00716305	C	11/28/2023	MEDICAL	0015	DEP		\$400.52	2023-258002763-0000		AVEANNA HEALTHCARE MEDICAL SC
00716306	C	11/28/2023	MEDICAL	0333	DEP		\$7.80	2023-282002378-0000		AVEANNA HEALTHCARE MEDICAL SC
00716307	C	11/28/2023	MEDICAL	0333	DEP		\$7.80	2023-282002379-0000		AVEANNA HEALTHCARE MEDICAL SC
00716308	C	11/28/2023	MEDICAL	0012	DEP		\$15.86	2023-310000878-0000		RADIOLOGY ASSOCIATES LLC
00716309	C	11/28/2023	MEDICAL	LAB3	DEP		\$2.70	2023-311001929-0000		CLASSEN FAMILY PRACTICE LLC
00716310	C	11/28/2023	MEDICAL	0153	DEP		\$78.30	2023-299001379-0000		CLASSEN URGENT CARE CLINIC LLC
00716311	C	11/28/2023	MEDICAL	WELL	DEP		\$18.17	2023-249000688-0000		DIAGNOSTIC LABORATORY OF OKLA
00716312	C	11/28/2023	MEDICAL	WELL	EMP		\$54.49	2023-311001490-0000		GI OF NORMAN
00716313	C	11/28/2023	MEDICAL	0010	EMP		\$98.16	2023-312000664-0000		PRIMARY CARE SOUTH OKC
00716314	C	11/28/2023	MEDICAL	0177	DEP		\$7.37	2023-258000888-0000		DIANON SYSTEMS INC
00716315	C	11/28/2023	MEDICAL	0177	DEP		\$69.46	2023-264000257-0000		DIAGNOSTIC LABORATORY OF OKLA
00716316	C	11/28/2023	MEDICAL	0066	DEP		\$1,080.00	2023-275000259-0000		NORMAN REGIONAL HOSPITAL
00716317	C	11/28/2023	MEDICAL	0066	DEP		\$72.19	2023-305004122-0000		NRHS RADIOLOGY ASSOCIATES
00716318	C	11/28/2023	MEDICAL	DXL3	DEP		\$72.00	2023-311000809-0000		THERAPY IN MOTION OF OKLAHOMA
00716319	C	11/28/2023	MEDICAL	0153	DEP		\$99.00	2023-312000846-0000		IMMEDIATE CARE OF OKLAHOMA LL
00716320	C	11/28/2023	MEDICAL	WELL	DEP		\$16.38	2023-250001284-0000		PATHOLOGY CONSULTATION SERVI
00716321	C	11/28/2023	MEDICAL	WELL	DEP		\$39.74	2023-250001285-0000		PATHOLOGY CONSULTATION SERVI
00716322	C	11/28/2023	MEDICAL	WELL	DEP		\$344.84	2023-296000975-0000		BLAIR KIRKPATRICK, MD
00716323	C	11/28/2023	MEDICAL	0010	DEP		\$171.77	2023-310001392-0000		MERCY CLINIC OKLAHOMA COMMUN
00716324	C	11/28/2023	M/N	0020	EMP		\$73.27	2023-312001014-0000		MERCY CLINIC OKLAHOMA COMMUN
00716325	C	11/28/2023	MEDICAL	0076	DEP		\$36.00	2023-310000959-0000		HOLLAND PEDIATRIC THERAPY
00716326	C	11/28/2023	MEDICAL	0010	DEP		\$41.09	2023-310001193-0000		NORMAN PEDIATRIC ASSOCIATES

DAILY CHECK REGISTER

City of Moore (70009)

First Fidelity Bank
 City of Moore (79023)

Check Number	Chk/EFT	Check Date	Type Expense	Cvg Type	Emp/Dep	Over Spec	Check Amount	Claim Number	Employee	Payee
00716327	C	11/28/2023	MEDICAL	DXL3	DEP		\$58.50	2023-312000964-0000		HOLLAND PEDIATRIC THERAPY
00716328	C	11/28/2023	MEDICAL	0076	DEP		\$36.00	2023-312000965-0000		HOLLAND PEDIATRIC THERAPY
00716329	C	11/28/2023	MEDICAL	0010	DEP		\$64.12	2023-275001580-0000		OKLAHOMA PAIN CENTER
00716330	C	11/28/2023	MEDICAL	0013	DEP		\$33.79	2023-289002163-0000		PATHOLOGY GROUP PC
00716331	C	11/28/2023	MEDICAL	0177	DEP		\$13.53	2023-296001519-0000		DIAGNOSTIC LABORATORY OF OKLAHOMA
00716332	C	11/28/2023	MEDICAL	0010	EMP		\$94.33	2023-311001915-0000		OHH PHYSICIANS, LLC
00716333	C	11/28/2023	MEDICAL	WELL	DEP		\$60.51	2023-314001868-0000		OHH PHYSICIANS, LLC
00716334	C	11/28/2023	MEDICAL	0004	DEP		\$415.80	2023-257000030-0000		INTEGRIS SOUTHWEST MEDICAL
00716335	C	11/28/2023	MEDICAL	0153	EMP		\$58.06	2023-310001191-0000		FIRST MED URGENT CARE LLC
00716336	C	11/28/2023	MEDICAL	0012	DEP		\$24.36	2023-310002010-0000		SOUTHWEST RADIOLOGY ASSOCIATES
00716337	C	11/28/2023	MEDICAL	0177	DEP		\$9.08	2023-305002797-0000		DIAGNOSTIC LABORATORY OF OKLAHOMA
00716338	C	11/28/2023	MEDICAL	0004	DEP		\$249.33	2023-310000253-0000		LAKESIDE WOMEN'S CENTER
00716339	C	11/28/2023	MEDICAL	0004	DEP		\$446.40	2023-311000427-0000		LAKESIDE WOMEN'S CENTER
00716340	C	11/28/2023	MEDICAL	0153	EMP		\$78.30	2023-311001132-0000		CLASSEN URGENT CARE CLINIC LLC
00716341	C	11/28/2023	MEDICAL	0177	EMP		\$63.59	2023-251000379-0000		DIGESTIVE DISEASE PATHOLOGY LLC
00716342	C	11/28/2023	MEDICAL	0047	EMP		\$412.33	2023-251000380-0000		DIGESTIVE DISEASE SPECIALISTS
00716343	C	11/28/2023	MEDICAL	0011	EMP		\$261.00	2023-258000944-0000		DIGESTIVE DISEASE SPECIALISTS
00716344	C	11/28/2023	MEDICAL	PRNR	DEP		\$2.99	2023-240001406-0000		NORMAN REGIONAL HOSPITAL
00716345	C	11/28/2023	MEDICAL	0021	DEP		\$652.86	2023-268000686-0000		NORMAN ANESTHESIA PROVIDERS INC
00716346	C	11/28/2023	MEDICAL	0009	DEP		\$383.27	2023-268001043-0000		OU HEALTH PARTNERS INC
00716347	C	11/28/2023	MEDICAL	0005	DEP		\$96.85	2023-275003594-0000		NORMAN PEDIATRIC ASSOCIATES
00716348	C	11/28/2023	MEDICAL	0009	DEP		\$95.01	2023-275003595-0000		NORMAN PEDIATRIC ASSOCIATES
00716349	C	11/28/2023	MEDICAL	0013	DEP		\$21.14	2023-275003597-0000		OU HEALTH PARTNERS INC
00716350	C	11/28/2023	MEDICAL	0009	DEP		\$192.24	2023-275003600-0000		OU HEALTH PARTNERS INC
00716351	C	11/28/2023	MEDICAL	0005	DEP		\$78.93	2023-282000472-0000		NORMAN PEDIATRIC ASSOCIATES
00716352	C	11/28/2023	MEDICAL	0002	DEP		\$1,015.20	2023-311000357-0000		NORMAN REGIONAL HOSPITAL

DAILY CHECK REGISTER

City of Moore (70009)

First Fidelity Bank
City of Moore (79023)

Check Number	Chk/ EFT	Check Date	Type Expense	Cvg Type	Emp/ Dep	Over Spec	Check Amount	Claim Number	Employee	Payee
00716353	C	11/28/2023	MEDICAL	0010	DEP		\$120.67	2023-310000858-0000		FOREFRONT DERMATOLOGY
00716354	C	11/28/2023	MEDICAL	LAB3	DEP		\$92.39	2023-312000880-0000		FOREFRONT DERMATOLOGY
00716355	C	11/28/2023	MEDICAL	0010	EMP		\$122.34	2023-313001495-0000		OU HEALTH PARTNERS INC
00716356	C	11/28/2023	MEDICAL	0177	EMP		\$11.73	2023-291001369-0000		DIANON SYSTEMS INC
00716357	C	11/28/2023	MEDICAL	WELL	DEP		\$59.12	2023-299000822-0000		BREAST CARE SPECIALISTS OF OK
00716358	C	11/28/2023	MEDICAL	0187	EMP		\$301.00	2023-292000051-0000		NORMAN ENDOSCOPY CENTER LLC
00716359	C	11/28/2023	MEDICAL	0011	EMP		\$132.26	2023-305003138-0000		NGA ANESTHESIA PLLC
00716360	C	11/28/2023	MEDICAL	0177	EMP		\$129.64	2023-258004434-0000		DIAGNOSTIC LABORATORY OF OKLA
00716361	C	11/28/2023	MEDICAL	0012	DEP		\$47.77	2023-258000171-0000		RADIOLOGY ASSOCIATES LLC
00716362	C	11/28/2023	MEDICAL	0177	DEP		\$22.18	2023-264000265-0000		DIAGNOSTIC LABORATORY OF OKLA
00716363	C	11/28/2023	MEDICAL	0177	DEP		\$9.30	2023-268001605-0000		DIAGNOSTIC LABORATORY OF OKLA
00716364	C	11/28/2023	MEDICAL	0177	DEP		\$114.73	2023-285001471-0000		DIAGNOSTIC LABORATORY OF OKLA
00716365	C	11/28/2023	MEDICAL	0177	DEP		\$56.60	2023-289002445-0000		DIAGNOSTIC LABORATORY OF OKLA
00716366	C	11/28/2023	MEDICAL	0073	DEP		\$522.17	2023-256000859-0000		PHYSICIAN MANAGEMENT SERVICES
00716367	C	11/28/2023	MEDICAL	0010	DEP		\$103.97	2023-310000600-0000		CARDIOVASCULAR HEALTH CLINIC I
00716368	C	11/28/2023	MEDICAL	0177	DEP		\$262.45	2023-289000900-0000		GENOVA DIAGNOSTICS INC
00716369	C	11/28/2023	MEDICAL	ERHS	DEP		\$805.50	2023-310000204-0000		NORMAN REGIONAL HOSPITAL
00716370	C	11/28/2023	MEDICAL	0004	EMP		\$148.94	2023-250000122-0000		OKLAHOMA HEART HOSPITAL
00716371	C	11/28/2023	MEDICAL	0177	DEP		\$4.81	2023-285000366-0000		DIAGNOSTIC LABORATORY OF OKLA
00716372	C	11/28/2023	MEDICAL	SUP2	DEP		\$68.95	2023-306000206-0000		SOUTHWEST ORTHOPAEDIC RECON
00716373	C	11/28/2023	MEDICAL	0177	EMP		\$83.54	2023-307000904-0000		DIAGNOSTIC LABORATORY OF OKLA
00716374	C	11/28/2023	MEDICAL	SUR3	EMP		\$201.05	2023-310000923-0000		OKLAHOMA OTOLARYNGOLOGY ASS
00716375	C	11/28/2023	MEDICAL	0010	EMP		\$87.31	2023-311001398-0000		FARHAN JAWED MD PLLC
00716376	C	11/28/2023	MEDICAL	0012	DEP		\$84.91	2023-255000574-0000		OU HEALTH PARTNERS INC
00716377	C	11/28/2023	MEDICAL	0009	DEP		\$260.78	2023-263000538-0000		OU HEALTH PARTNERS INC
00716378	C	11/28/2023	MEDICAL	0012	DEP		\$161.11	2023-263000539-0000		OU HEALTH PARTNERS INC

DAILY CHECK REGISTER

City of Moore (70009)

First Fidelity Bank
City of Moore (79023)

Check Number	Chk/EFT	Check Date	Type Expense	Cvg Type	Emp/Dep	Over Spec	Check Amount	Claim Number	Employee	Payee
00716379	C	11/28/2023	MEDICAL	0066	DEP		\$110.16	2023-297002306-0000		OU HEALTH PARTNERS INC
00716380	C	11/28/2023	MEDICAL	0177	DEP		\$22.04	2023-296001520-0000		DIAGNOSTIC LABORATORY OF OKLA
00716381	C	11/28/2023	MEDICAL	0010	DEP		\$48.91	2023-311001970-0000		SAINTS MEDICAL GROUP LLC
00716382	C	11/28/2023	MEDICAL	0013	DEP		\$19.06	2023-258003451-0000		PATHOLOGY GROUP PC
00716383	C	11/28/2023	MEDICAL	0072	DEP		\$829.25	2023-262000181-0000		NORMAN REGIONAL HOSPITAL
00716384	C	11/28/2023	MEDICAL	0021	DEP		\$832.00	2023-262000330-0000		AFFILIATED ANESTHESIOLOGIST, LI
00716385	C	11/28/2023	MEDICAL	0047	DEP		\$183.91	2023-289002658-0000		BRANT BENNETT MD PLLC
00716386	C	11/28/2023	MEDICAL	0028	DEP		\$29.71	2023-291001110-0000		ARGENCIS MEDICAL INC
00716387	C	11/28/2023	MEDICAL	0333	DEP		\$24.54	2023-299000870-0000		BRANT BENNETT MD PLLC
00716388	C	11/28/2023	MEDICAL	0010	EMP		\$108.59	2023-311001763-0000		MERCY CLINIC OKLAHOMA COMMUN
00716389	C	11/28/2023	MEDICAL	0177	DEP		\$178.87	2023-293000497-0000		LABCORP DALLAS
00716390	C	11/28/2023	MEDICAL	0153	EMP		\$54.00	2023-310001586-0000		QUICK URGENT CARE
00716391	C	11/28/2023	MEDICAL	0010	EMP		\$69.04	2023-310001587-0000		QUICK URGENT CARE
00716392	C	11/28/2023	MEDICAL	0009	DEP		\$174.35	2023-279000959-0000		SAINTS MEDICAL GROUP LLC
00716393	C	11/28/2023	MEDICAL	0068	DEP		\$102.40	2023-310000471-0000		FUSION MD
00716394	C	11/28/2023	MEDICAL	0068	DEP		\$108.94	2023-310000472-0000		FUSION MD
00716395	C	11/28/2023	MEDICAL	0068	DEP		\$108.94	2023-310000473-0000		FUSION MD
00716396	C	11/28/2023	MEDICAL	0177	DEP		\$63.59	2023-262001656-0000		DIGESTIVE DISEASE PATHOLOGY LL
00716397	C	11/28/2023	MEDICAL	0047	DEP		\$412.33	2023-262001657-0000		DIGESTIVE DISEASE SPECIALISTS
00716398	C	11/28/2023	M/N	0020	EMP		\$71.81	2023-311000793-0000		JESSICA SMITH
00716399	C	11/28/2023	MEDICAL	WELL	DEP		\$489.00	2023-275000654-0000		NORMAN ENDOSCOPY CENTER LLC
00716400	C	11/28/2023	MEDICAL	0177	EMP		\$16.98	2023-307000880-0000		LABORATORY CORPORATION OF AM
00716401	C	11/28/2023	MEDICAL	DXL3	EMP		\$1,144.71	2023-310001857-0000		ORTHO CENTRAL
00716402	C	11/28/2023	MEDICAL	0010	EMP		\$87.91	2023-221000444-0000		OKLAHOMA OTOLARYNGOLOGY ASS
00716403	C	11/28/2023	MEDICAL	WELL	DEP		\$457.98	2023-286000330-0000		EXACT SCIENCES LABORATORIES
00716404	C	11/28/2023	MISC	0100	DEP		\$453.00	2023-313002998-0000		MedWatch LLC

DAILY CHECK REGISTER

City of Moore (70009)

First Fidelity Bank
 City of Moore (79023)

Check Number	Chk/ EFT	Check Date	Type Expense	Cvg Type	Emp/ Dep	Over Spec	Check Amount	Claim Number	Employee	Payee
00716405	C	11/28/2023	MEDICAL	0153	DEP		\$186.04	2023-299000501-0000		PREMIERE PEDIATRICS PLLC
00716406	C	11/28/2023	MEDICAL	0045	DEP		\$122.07	2023-299000502-0000		PREMIERE PEDIATRICS PLLC
00716407	C	11/28/2023	MEDICAL	0035	DEP		\$24.85	2023-305001561-0000		HEARTS FOR HEARING FOUNDATIOI
00716408	C	11/28/2023	MEDICAL	0010	DEP		\$108.26	2023-310000490-0000		DARREN ELENBURG DPM PC
00716409	C	11/28/2023	M/N	0020	EMP		\$71.81	2023-310000833-0000		JESSICA SMITH
00716410	C	11/28/2023	MEDICAL	0010	DEP		\$31.19	2023-305003859-0000		SOUTH CENTRAL MEDICAL
00716411	C	11/28/2023	MEDICAL	0153	EMP		\$99.00	2023-312000480-0000		IMMEDIATE CARE OF OKLAHOMA LL
00716412	C	11/28/2023	MEDICAL	0004	EMP		\$1,278.14	2023-258000092-0000		OKLAHOMA HEART HOSPITAL SOUTI
00716413	C	11/28/2023	MEDICAL	0004	EMP		\$282.44	2023-268000098-0000		OKLAHOMA HEART HOSPITAL SOUTI
00716414	C	11/28/2023	MEDICAL	0177	EMP		\$5.80	2023-289002442-0000		DIAGNOSTIC LABORATORY OF OKLA
00716415	C	11/28/2023	MEDICAL	0177	DEP		\$66.62	2023-289002548-0000		DIAGNOSTIC PATHOLOGY SERVICES
00716416	C	11/28/2023	MEDICAL	0017	EMP		\$1,952.98	2023-251000178-0000		COMMUNITY HOSPITAL
00716417	C	11/28/2023	MEDICAL	0177	DEP		\$17.67	2023-254000780-0000		NORMAN REGIONAL HOSPITAL
00716418	C	11/28/2023	MEDICAL	0177	EMP		\$68.50	2023-289000941-0000		LABORATORY CORPORATION OF AI
00716419	C	11/28/2023	MEDICAL	WELL	EMP		\$42.26	2023-255000843-0000		DIAGNOSTIC LABORATORY OF OKLA
00716420	C	11/28/2023	MEDICAL	0153	DEP		\$54.00	2023-305002484-0000		QUICK URGENT CARE
00716421	C	11/28/2023	MEDICAL	0010	EMP		\$166.97	2023-310001165-0000		ENDOCRINE PARATHYROID CENTER
00716422	C	11/28/2023	MISC	0100	EMP		\$377.50	2023-317002301-0000		MedWatch LLC
00716423	C	11/28/2023	MEDICAL	WELL	DEP		\$34.59	2023-311001043-0000		MATTISON PATHOLOGY LLP DBA AVI
00716424	C	11/28/2023	MEDICAL	0039	DEP		\$175.55	2023-311001813-0000		STILLWATER MEDICAL CENTER
00716425	C	11/28/2023	MEDICAL	0010	DEP		\$24.37	2023-318000867-0000		INTEGRIS AMBULATORY CARE CORP
00716426	C	11/28/2023	MEDICAL	0004	EMP		\$33.64	2023-318001679-0000		INTEGRIS BAPTIST MEDICAL CENTE
00716427	C	11/28/2023	MEDICAL	0177	DEP		\$47.23	2023-289001035-0000		DIAGNOSTIC LABORATORY OF OKLA
00716428	C	11/28/2023	MEDICAL	0010	DEP		\$63.96	2023-311001324-0000		NHUNG H. PHAM PA-C
00716429	C	11/28/2023	MEDICAL	0010	EMP		\$13.67	2023-311001325-0000		NHUNG H. PHAM PA-C
00716430	C	11/28/2023	MEDICAL	WELL	EMP		\$42.26	2023-293000872-0000		DIAGNOSTIC LABORATORY OF OKLA

DAILY CHECK REGISTER

City of Moore (70009)

First Fidelity Bank
 City of Moore (79023)

Check Number	Chk/EFT	Check Date	Type Expense	Cvg Type	Emp/Dep	Over Spec	Check Amount	Claim Number	Employee	Payee
00716431	C	11/28/2023	MEDICAL	0177	EMP		\$9.49	2023-293000348-0000		LABORATORY CORPORATION OF AM
00716432	C	11/28/2023	MEDICAL	0153	DEP		\$78.30	2023-305002202-0000		CLASSEN URGENT CARE CLINIC LLC
00716433	C	11/28/2023	MEDICAL	WELL	EMP		\$23.10	2023-299001206-0000		QUEST DIAGNOSTICS ATLANTA
00716434	C	11/28/2023	MEDICAL	0177	DEP		\$145.60	2023-299001800-0000		LABORATORY CORPORATION OF AM
00716435	C	11/28/2023	MEDICAL	0177	DEP		\$65.15	2023-299000619-0000		DIAGNOSTIC LABORATORY OF OKLA
00716436	C	11/28/2023	MEDICAL	0039	DEP		\$129.92	2023-310001270-0000		JULIE L WILEY, DO, PLLC
00716437	C	11/28/2023	MEDICAL	0076	DEP		\$36.00	2023-310000966-0000		HOLLAND PEDIATRIC THERAPY
00716438	C	11/28/2023	MEDICAL	0076	DEP		\$36.00	2023-311001544-0000		HOLLAND PEDIATRIC THERAPY
00716439	C	11/28/2023	MEDICAL	0004	EMP		\$47.68	2023-255000217-0000		OKLAHOMA CITY VAMC
00716440	C	11/28/2023	MEDICAL	0177	EMP		\$28.68	2023-264000267-0000		DIAGNOSTIC LABORATORY OF OKLA
00716441	C	11/28/2023	MEDICAL	WELL	DEP		\$90.44	2023-255000885-0000		QUEST DIAGNOSTICS LENEXA
00716442	C	11/28/2023	MEDICAL	WELL	DEP		\$48.18	2023-268001601-0000		DIAGNOSTIC LABORATORY OF OKLA
00716443	C	11/28/2023	MEDICAL	WELL	DEP		\$19.46	2023-284000722-0000		PATHOLOGY CONSULTATION SERVI
00716444	C	11/28/2023	MEDICAL	0004	EMP		\$23.63	2023-305000298-0000		OKLAHOMA HEART HOSPITAL
00716445	C	11/28/2023	MEDICAL	0004	EMP		\$346.50	2023-263000092-0000		NORMAN REGIONAL HOSPITAL
00716446	C	11/28/2023	MEDICAL	0004	DEP		\$687.15	2023-282000191-0000		ADA VA CLINIC
00716447	C	11/28/2023	MISC	0100	EMP		\$402.67	2023-317002451-0000		MedWatch LLC
00716448	C	11/28/2023	MEDICAL	0177	EMP		\$15.85	2023-296001521-0000		QUEST DIAGNOSTICS ATLANTA
00716449	C	11/28/2023	MEDICAL	0177	DEP		\$18.40	2023-279000815-0000		DIAGNOSTIC LABORATORY OF OKLA
00716450	C	11/28/2023	MEDICAL	0010	DEP		\$170.67	2023-312000522-0000		UROGYNECOLOGY OF OKLAHOMA PI
00716451	C	11/28/2023	MEDICAL	0010	EMP		\$120.21	2023-313001450-0000		YAOHAN LAM DERMATOLOGY PLLC
00716452	C	11/28/2023	MEDICAL	WELL	DEP		\$8.58	2023-254002069-0000		LABORATORY CORPORATION OF AM
00716453	C	11/28/2023	MEDICAL	WELL	DEP		\$16.38	2023-285000191-0000		PATHOLOGY CONSULTATION SERVI
00716454	C	11/28/2023	MEDICAL	WELL	DEP		\$42.26	2023-296001517-0000		DIAGNOSTIC LABORATORY OF OKLA
00716455	C	11/28/2023	MEDICAL	0153	EMP		\$23.40	2023-314000904-0000		CLASSEN URGENT CARE CLINIC LLC
00716456	C	11/28/2023	MEDICAL	0177	EMP		\$1,135.44	2023-258000179-0000		NATERA INC

DAILY CHECK REGISTER

City of Moore (70009)

First Fidelity Bank
City of Moore (79023)

Check Number	Chk/EFT	Check Date	Type Expense	Cvg Type	Emp/Dep	Over Spec	Check Amount	Claim Number	Employee	Payee
00716457	C	11/28/2023	MEDICAL	0177	EMP		\$29.95	2023-305000688-0000		DIAGNOSTIC PATHOLOGY SERVICES
00716458	C	11/28/2023	MEDICAL	0010	DEP		\$11.31	2023-314002158-0000		CENTRAL OK OB/GYN ASSOC
00716459	C	11/28/2023	MEDICAL	WELL	DEP		\$21.78	2023-285001473-0000		DIAGNOSTIC LABORATORY OF OKLA
00716460	C	11/28/2023	MEDICAL	0010	DEP		\$129.86	2023-314000477-0000		HOMETOWN HEALTHCARE
00716461	C	11/28/2023	MEDICAL	0066	EMP		\$72.19	2023-289001164-0000		NRHS RADIOLOGY ASSOCIATES
00716462	C	11/28/2023	MEDICAL	0035	EMP		\$179.67	2023-296000209-0000		THE SLEEP CLINIC
00716463	C	11/28/2023	MEDICAL	0035	EMP		\$399.47	2023-258003398-0000		OHH PHYSICIANS, LLC
00716464	C	11/28/2023	MEDICAL	0066	EMP		\$184.66	2023-286001699-0000		TOUCHSTONE IMAGING OKLAHOMA
00716465	C	11/28/2023	MEDICAL	0066	EMP		\$8.96	2023-297001879-0000		RADIOLOGY CONSULTANTS INC
00716466	C	11/28/2023	MEDICAL	DXL3	DEP		\$1,628.03	2023-311000873-0000		OKLAHOMA ARTHRITIS CENTER
00716467	C	11/28/2023	MEDICAL	0010	EMP		\$91.58	2023-310000938-0000		JWS MEDICAL, PLLC
00716468	C	11/28/2023	MEDICAL	0004	EMP		\$897.30	2023-306000056-0000		SUMMIT MEDICAL CENTER LLC
00716469	C	11/28/2023	MEDICAL	0017	EMP		\$49.50	2023-311001517-0000		THERAPY IN MOTION OF OKLAHOMA
00716470	C	11/28/2023	MEDICAL	0012	DEP		\$6.73	2023-305004123-0000		NRHS RADIOLOGY ASSOCIATES
00716471	C	11/28/2023	MEDICAL	0005	DEP		\$100.07	2023-254000230-0000		MERCY CLINIC OKLAHOMA COMMUN
00716472	C	11/28/2023	MEDICAL	0153	DEP		\$78.30	2023-300000849-0000		CLASSEN URGENT CARE CLINIC LLC
00716473	C	11/28/2023	MEDICAL	0010	DEP		\$128.28	2023-314000478-0000		HOMETOWN HEALTHCARE
00716474	C	11/28/2023	MEDICAL	0010	DEP		\$112.89	2023-240001180-0000		THE PHYSICIANS GROUP LLC
00716475	C	11/28/2023	MEDICAL	0080	DEP		\$6.75	2023-310001214-0000		OKLAHOMA ALLERGY AND ASTHMA C
00716476	C	11/28/2023	MEDICAL	0010	DEP		\$240.31	2023-289001415-0000		HEALTHCARE EXPRESS LLP
00716477	C	11/28/2023	MEDICAL	0010	EMP		\$69.60	2023-311000680-0000		YOUR HEALTH WELLNESS
00716478	C	11/28/2023	MEDICAL	0018	DEP		\$68.51	2023-263001165-0000		BODIN CHIROPRACTIC PLLC
00716479	C	11/28/2023	MEDICAL	0177	EMP		\$43.81	2023-283000637-0000		QUEST DIAGNOSTICS ATLANTA
00716480	C	11/28/2023	MEDICAL	0177	EMP		\$19.94	2023-305003943-0000		QUEST DIAGNOSTICS ATLANTA
00716481	C	11/28/2023	M/N	0020	DEP		\$348.98	2023-286001805-0000		ADONIS AL-BOTROS
00716482	C	11/28/2023	MEDICAL	0010	EMP		\$82.62	2023-290003764-0000		BALANCE HORMONE OKLAHOMA PLI

DAILY CHECK REGISTER

City of Moore (70009)

First Fidelity Bank
 City of Moore (79023)

Check Number	Chk/EFT	Check Date	Type Expense	Cvg Type	Emp/Dep	Over Spec	Check Amount	Claim Number	Employee	Payee
00716483	C	11/28/2023	MEDICAL	0009	DEP		\$474.67	2023-305002859-0000		ADONIS AL-BOTROS
00716484	C	11/28/2023	MEDICAL	0009	DEP		\$369.47	2023-305002860-0000		ADONIS AL-BOTROS
00716485	C	11/28/2023	MEDICAL	0004	DEP		\$38.28	2023-310000080-0000		ST ANTHONY HOSPITAL SSM HEALTH
00716486	C	11/28/2023	MEDICAL	0177	EMP		\$60.29	2023-270000231-0000		LABORATORY CORPORATION OF AM
00716487	C	11/28/2023	MEDICAL	WELL	DEP		\$312.00	2023-290000179-0000		INTEGRIS SOUTHWEST MEDICAL
00716488	C	11/28/2023	MEDICAL	0035	DEP		\$9.10	2023-297001852-0000		SOUTHWEST RADIOLOGY ASSOCIAT
00716489	C	11/28/2023	MEDICAL	0177	EMP		\$19.61	2023-305002801-0000		DIAGNOSTIC LABORATORY OF OKLA
00716490	C	11/28/2023	MEDICAL	WELL	EMP		\$133.62	2023-314002020-0000		INTEGRIS MEDICAL GROUP
00716491	C	11/28/2023	MEDICAL	0010	EMP		\$97.76	2023-310001729-0000		INTEGRIS MEDICAL GROUP
00716492	C	11/28/2023	MEDICAL	0177	DEP		\$53.28	2023-264000260-0000		DIAGNOSTIC LABORATORY OF OKLA
00716493	C	11/28/2023	MEDICAL	0010	DEP		\$68.84	2023-310000458-0000		MIDWEST NEPHROLOGY GROUP PLL
00716494	C	11/28/2023	MEDICAL	0177	DEP		\$1.88	2023-310001984-0000		DIAGNOSTIC LABORATORY OF OKLA
00716495	C	11/28/2023	MEDICAL	DXL3	DEP		\$1,701.29	2023-313001510-0000		DEAN MC GEE EYE INSTITUTE
00716496	C	11/28/2023	MEDICAL	0153	EMP		\$23.40	2023-314000905-0000		CLASSEN URGENT CARE CLINIC LLC
00716497	C	11/28/2023	MEDICAL	0047	EMP		\$333.40	2023-250000301-0000		SOUTHWEST GASTROENTEROLOGY
00716498	C	11/28/2023	MEDICAL	0021	EMP		\$865.24	2023-275003521-0000		METROPLEX PATHOLOGY ASSOCIAT
00716499	C	11/28/2023	MEDICAL	0010	DEP		\$82.41	2023-310001824-0000		NORMAN PEDIATRIC ASSOCIATES
00716500	C	11/28/2023	MEDICAL	0076	DEP		\$36.00	2023-310001926-0000		HOLLAND PEDIATRIC THERAPY
00716501	C	11/28/2023	MEDICAL	0076	DEP		\$36.00	2023-312000701-0000		HOLLAND PEDIATRIC THERAPY
00716502	C	11/28/2023	MEDICAL	LAB3	DEP		\$77.18	2023-286000734-0000		PATHOLOGY LAB ASSOCIATES
00716503	C	11/28/2023	MEDICAL	0080	DEP		\$7.79	2023-310001212-0000		OKLAHOMA ALLERGY AND ASTHMA C
00716504	C	11/28/2023	MEDICAL	0010	EMP		\$235.69	2023-310001369-0000		SAINTS MEDICAL GROUP LLC
00716505	C	11/28/2023	MEDICAL	0333	EMP		\$183.71	2023-313001610-0000		NORMAN REGIONAL HOSPITAL AUTI
00716506	C	11/28/2023	MEDICAL	0010	EMP		\$42.73	2023-310000560-0000		BALANCE HORMONE OKLAHOMA PLI
00716507	C	11/28/2023	MEDICAL	0010	EMP		\$106.56	2023-311000734-0000		SAINTS MEDICAL GROUP LLC
00716508	C	11/28/2023	MEDICAL	XRY2	EMP		\$4.80	2023-311001969-0000		SAINTS MEDICAL GROUP LLC

DAILY CHECK REGISTER

City of Moore (70009)

First Fidelity Bank
 City of Moore (79023)

Check Number	Chk/EFT	Check Date	Type Expense	Cvg Type	Emp/Dep	Over Spec	Check Amount	Claim Number	Employee	Payee
00716509	C	11/28/2023	MEDICAL	0177	EMP		\$86.68	2023-254002517-0000		DIAGNOSTIC LABORATORY OF OKLAHOMA
00716510	C	11/28/2023	MEDICAL	0010	DEP		\$55.90	2023-310001340-0000		CLASSEN FAMILY PRACTICE LLC
00716511	C	11/28/2023	MEDICAL	WELL	EMP		\$58.77	2023-254002518-0000		QUEST DIAGNOSTICS ATLANTA
00716512	C	11/28/2023	MEDICAL	WELL	EMP		\$676.44	2023-243005719-0000		DIAGNOSTIC LABORATORY OF OKLAHOMA
00716513	C	11/28/2023	MEDICAL	0177	EMP		\$11.35	2023-305003947-0000		DIAGNOSTIC LABORATORY OF OKLAHOMA
00716514	C	11/28/2023	MEDICAL	0047	EMP		\$414.99	2023-310001807-0000		DIGESTIVE DISEASE SPECIALISTS
00716515	C	11/28/2023	MEDICAL	0177	DEP		\$69.65	2023-310001976-0000		QUEST DIAGNOSTICS ATLANTA
00716516	C	11/28/2023	MEDICAL	0010	DEP		\$149.95	2023-311000952-0000		MERCY CLINIC OKLAHOMA COMMUNITY
00716517	C	11/28/2023	MEDICAL	0010	DEP		\$105.89	2023-311001766-0000		MERCY CLINIC OKLAHOMA COMMUNITY
00716518	C	11/28/2023	MEDICAL	0010	EMP		\$207.91	2023-293002411-0000		MCBRIDE ORTHOPEDIC- HOSPITAL
00716519	C	11/28/2023	M/N	0020	DEP		\$71.81	2023-311000789-0000		AMANDA BRANDON
00716520	C	11/28/2023	MEDICAL	0010	DEP		\$70.96	2023-310000696-0000		THE PHYSICIANS GROUP LLC
00716521	C	11/28/2023	MEDICAL	0073	DEP		\$70.12	2023-311001955-0000		PHYSICIAN MANAGEMENT SERVICES
00716522	C	11/28/2023	MEDICAL	0066	EMP		\$54.21	2023-290000434-0000		EAGLE PARTNERS PLLC
00716523	C	11/28/2023	MEDICAL	0017	EMP		\$83.22	2023-310001204-0000		YUKON WOUND CARE REHAB PLLC
00716524	C	11/28/2023	MEDICAL	0017	EMP		\$36.00	2023-312000463-0000		YUKON WOUND CARE REHAB PLLC
00716525	C	11/28/2023	MEDICAL	0011	DEP		\$576.60	2023-299000755-0000		NORMAN ANESTHESIA PROVIDERS INC
00716526	C	11/28/2023	MEDICAL	WELL	DEP		\$8.88	2023-282001459-0000		CLINICAL PATHOLOGY LABS INC
00716527	C	11/28/2023	MEDICAL	WELL	EMP		\$76.93	2023-310002007-0000		THE PHYSICIANS GROUP LLC
00716528	C	11/28/2023	MEDICAL	0177	DEP		\$171.71	2023-305001119-0000		QUEST DIAGNOSTICS LENEXA
00716529	C	11/28/2023	MEDICAL	0039	DEP		\$141.03	2023-311001771-0000		MERCY CLINIC OKLAHOMA COMMUNITY
00716530	C	11/28/2023	MEDICAL	WELL	EMP		\$34.65	2023-305000965-0000		QUEST DIAGNOSTICS ATLANTA
00716531	C	11/28/2023	MEDICAL	0177	EMP		\$19.61	2023-305000925-0000		DIAGNOSTIC LABORATORY OF OKLAHOMA
00716532	C	11/28/2023	MEDICAL	0153	DEP		\$255.42	2023-240001140-0000		HEALTHTRACKRX INDIANA, INC.
00716533	C	11/28/2023	MEDICAL	0066	DEP		\$120.79	2023-289001881-0000		OU HEALTH PARTNERS INC
00716534	C	11/28/2023	MEDICAL	0177	EMP		\$108.00	2023-240001128-0000		ETHOS LABS

DAILY CHECK REGISTER

City of Moore (70009)

First Fidelity Bank
City of Moore (79023)

Check Number	Chk/EFT	Check Date	Type Expense	Cvg Type	Emp/Dep	Over Spec	Check Amount	Claim Number	Employee	Payee
00716535	C	11/28/2023	MEDICAL	0177	DEP		\$5.22	2023-289001793-0000		DIAGNOSTIC LABORATORY OF OKLA
00716536	C	11/28/2023	MEDICAL	0177	DEP		\$22.20	2023-305003984-0000		DIAGNOSTIC LABORATORY OF OKLA
00716537	C	11/28/2023	MEDICAL	0177	EMP		\$33.19	2023-249000692-0000		DIAGNOSTIC LABORATORY OF OKLA
00716538	C	11/28/2023	MEDICAL	0177	DEP		\$13.03	2023-249001123-0000		LABORATORY CORPORATION OF AM
00716539	C	11/28/2023	MEDICAL	0012	DEP		\$93.09	2023-293000267-0000		EAGLE PARTNERS PLLC
00716540	C	11/28/2023	MEDICAL	0177	EMP		\$50.02	2023-279000818-0000		DIAGNOSTIC LABORATORY OF OKLA
00716541	C	11/28/2023	MEDICAL	0035	DEP		\$46.78	2023-310000874-0000		DIAGNOSTIC IMAGING ASSOCIATES
00716542	C	11/28/2023	MEDICAL	0019	EMP		\$103.50	2023-311001739-0000		SPARKS CLINIC
00716543	C	11/28/2023	MEDICAL	0019	DEP		\$158.35	2023-311001740-0000		SPARKS CLINIC
00716544	C	11/28/2023	MEDICAL	0177	EMP		\$92.15	2023-243005677-0000		DIAGNOSTIC LABORATORY OF OKLA
00716545	C	11/28/2023	MEDICAL	0177	EMP		\$43.03	2023-243005706-0000		DIAGNOSTIC LABORATORY OF OKLA
00716546	C	11/28/2023	MEDICAL	0177	EMP		\$108.73	2023-243005722-0000		DIAGNOSTIC LABORATORY OF OKLA
00716547	C	11/28/2023	MEDICAL	0010	EMP		\$83.84	2023-311001906-0000		SAINTS MEDICAL GROUP LLC

299 CHECKS PAID AMOUNTING TO \$121,901.09 ✓
299 PAYMENTS AMOUNTING TO \$121,901.09

ELECTRONIC PAYMENTS AMOUNTING TO \$0.00

0 TOTAL ADJUSTMENTS FOR \$0.00

BREAKDOWN	Medical	Dental	Vision	Drug	Other	Excess
CHECKS	290	0	0	0	9	0
TOTALS	\$119,958.43	\$0.00	\$0.00	\$0.00	\$1,942.66	\$0.00

DAILY CHECK REGISTER

City of Moore (70009)

First Fidelity Bank
 City of Moore (79024)

Check Number	Chk/EFT	Check Date	Type Expense	Cvg Type	Emp/Dep	Over Spec	Check Amount	Claim Number	Employee	Payee
00716548	C	11/28/2023	MEDICAL	0010	DEP		\$124.00	2023-263003046-0000		EYE ASSOCIATES OF OKLAHOMA
00716549	C	11/28/2023	MEDICAL	0010	DEP		\$96.00	2023-269002075-0000		EYE ASSOCIATES OF OKLAHOMA
2 CHECKS PAID AMOUNTING TO \$220.00 ✓ 2 PAYMENTS AMOUNTING TO \$220.00							ELECTRONIC PAYMENTS AMOUNTING TO \$0.00			0 TOTAL ADJUSTMENTS FOR \$0.00

BREAKDOWN	Medical	Dental	Vision	Drug	Other	Excess
CHECKS	2	0	0	0	0	0
TOTALS	\$220.00	\$0.00	\$0.00	\$0.00	\$0.00	\$0.00

DAILY CHECK REGISTER

City of Moore (70009)

First Fidelity Bank
 City of Moore (79025)

Check Number	Chk/EFT	Check Date	Type Expense	Cvg Type	Emp/Dep	Over Spec	Check Amount	Claim Number	Employee	Payee
00716550	C	11/28/2023	MEDICAL	0004	EMP		\$104.87	2023-268000053-0000		OKLAHOMA CITY VAMC
00716551	C	11/28/2023	MEDICAL	0010	EMP		\$41.06	2023-268000354-0000		OKLAHOMA CITY VAMC
2 CHECKS PAID AMOUNTING TO \$145.93 ✓							ELECTRONIC PAYMENTS AMOUNTING TO \$0.00			0 TOTAL ADJUSTMENTS FOR \$0.00
2 PAYMENTS AMOUNTING TO \$145.93										

BREAKDOWN	Medical	Dental	Vision	Drug	Other	Excess
CHECKS	2	0	0	0	0	0
TOTALS	\$145.93	\$0.00	\$0.00	\$0.00	\$0.00	\$0.00

Check Register From History

City of Moore (70009)

City of Moore (79023)

First Fidelity Bank

Reporting From 12/5/2023 Thru 12/5/2023

Check Number	Chk/ EFT	Check Date	Type Expenses	CVG TYPE	EMP/ DEP	Over Spec	Check Amount	Claim Number	Payee
00716552	C	12/5/2023	Medical	0004	EMP		\$2,782.80	2023-314000772-0000	COMMUNITY HOSPITAL
00716553	C	12/5/2023	Medical	0018	EMP		\$166.50	2023-325001333-0000	SPARKS CLINIC
00716554	C	12/5/2023	Medical	DXL3	EMP		\$109.89	2023-325002048-0000	INTEGRIS MEDICAL GROUP
00716555	C	12/5/2023	Medical	0010	DEP		\$81.59	2023-326000155-0000	PRIMARY CARE-PURCELL
00716556	C	12/5/2023	Medical	0068	DEP		\$128.13	2023-325001549-0000	NORTHSIDE PEDIATRIC
00716557	C	12/5/2023	M/N	0020	EMP		\$71.81	2023-331005105-0000	BRANDI GIBSON LADC
00716558	C	12/5/2023	Medical	0010	DEP		\$35.76	2023-324000361-0000	OMNI EYE CENTER EDMOND
00716559	C	12/5/2023	Medical	0021	EMP		\$46.04	2023-324000719-0000	BRANTLEY MEDICAL PLLC
00716560	C	12/5/2023	Medical	0010	DEP		\$32.33	2023-324000418-0000	ZANN MCMAHAN MD PC
00716561	C	12/5/2023	Medical	0010	DEP		\$32.33	2023-324000419-0000	ZANN MCMAHAN MD PC
00716562	C	12/5/2023	Medical	0010	DEP		\$83.43	2023-325001362-0000	AKY MD LLC DBA JUST KIDS
00716563	C	12/5/2023	Misc	DIRC	DEP		\$325.00	2023-326000012-0000	ATLAS BILLING COMPANY
00716564	C	12/5/2023	Medical	0009	DEP		\$201.96	2023-320001920-0000	OU HEALTH PARTNERS INC
00716565	C	12/5/2023	Medical	0010	DEP		\$17.10	2023-321000276-0000	PRIMARY CARE SOUTH OKC
00716566	C	12/5/2023	Medical	0010	DEP		\$47.01	2023-325001560-0000	DAVID K DUNCAN MD
00716567	C	12/5/2023	M/N	0020	EMP		\$101.89	2023-324000603-0000	BALANCE WOMEN HEALTH
00716568	C	12/5/2023	Medical	0333	EMP		\$341.96	2023-240001257-0000	ZYNEX MEDICAL
00716569	C	12/5/2023	Medical	0333	EMP		\$240.95	2023-250001034-0000	ZYNEX MEDICAL
00716570	C	12/5/2023	Medical	ERHS	EMP		\$2,670.67	2023-262000182-0000	NORMAN REGIONAL
00716571	C	12/5/2023	Medical	0017	EMP		\$102.43	2023-325000305-0000	ORTHO CENTRAL
00716572	C	12/5/2023	Medical	DXL3	DEP		\$58.60	2023-325001715-0000	CLASSEN FAMILY PRACTICE
00716573	C	12/5/2023	Medical	0177	DEP		\$8.22	2023-325001872-0000	LABORATORY CORPORATION
00716574	C	12/5/2023	Medical	0010	DEP		\$52.99	2023-325000561-0000	SAINTS MEDICAL GROUP LLC
00716575	C	12/5/2023	Medical	0010	DEP		\$71.74	2023-325001757-0000	DINA M BOWEN MD PLLC
00716576	C	12/5/2023	Medical	0010	EMP		\$105.89	2023-321000672-0000	MERCY CLINIC OKLAHOMA
00716577	C	12/5/2023	Medical	WELL	DEP		\$28.82	2023-321000207-0000	NORMAN REGIONAL
00716578	C	12/5/2023	Medical	0018	EMP		\$40.50	2023-331000031-0000	AUSTIN FREEMAN
00716579	C	12/5/2023	Medical	0333	DEP		\$242.14	2023-321000807-0000	AVEANNA HEALTHCARE
00716580	C	12/5/2023	Medical	DXL3	DEP		\$65.00	2023-324000978-0000	OPTC COMPLETE REHAB, LLC
00716581	C	12/5/2023	Medical	0076	DEP		\$65.00	2023-324000979-0000	OPTC COMPLETE REHAB, LLC
00716582	C	12/5/2023	Medical	0076	DEP		\$40.00	2023-324000980-0000	OPTC COMPLETE REHAB, LLC

Check Register From History

City of Moore (70009)

City of Moore (79023)

First Fidelity Bank

Reporting From 12/5/2023 Thru 12/5/2023

Check Number	Chk/ EFT	Check Date	Type Expenses	CVG TYPE	EMP/ DEP	Over Spec	Check Amount	Claim Number	Payee
00716583	C	12/5/2023	Medical	0017	DEP		\$65.00	2023-324000981-0000	OPTC COMPLETE REHAB, LLC
00716584	C	12/5/2023	Medical	0028	DEP		\$54.22	2023-324001495-0000	AVEANNA HEALTHCARE
00716585	C	12/5/2023	Medical	0028	DEP		\$411.16	2023-324001496-0000	AVEANNA HEALTHCARE
00716586	C	12/5/2023	Medical	SUP3	DEP		\$88.80	2023-324001497-0000	AVEANNA HEALTHCARE
00716587	C	12/5/2023	Medical	0010	DEP		\$35.76	2023-324001928-0000	DONNA COSBY
00716588	C	12/5/2023	Medical	0153	DEP		\$78.30	2023-325001717-0000	CLASSEN URGENT CARE
00716589	C	12/5/2023	Medical	0010	DEP		\$68.70	2023-321001250-0000	CLASSEN FAMILY PRACTICE
00716590	C	12/5/2023	Medical	0068	DEP		\$335.96	2023-321000592-0000	SAINTS MEDICAL GROUP LLC
00716591	C	12/5/2023	Medical	XRY2	DEP		\$127.23	2023-325000861-0000	OU HEALTH PARTNERS INC
00716592	C	12/5/2023	Medical	ERHS	DEP		\$2,373.90	2023-250000123-0000	NORMAN REGIONAL
00716593	C	12/5/2023	Medical	0011	DEP		\$472.11	2023-321001413-0000	OU HEALTH PARTNERS INC
00716594	C	12/5/2023	Medical	0027	DEP		\$31.31	2023-324000567-0000	NRHS RADIOLOGY
00716595	C	12/5/2023	Medical	0027	DEP		\$125.80	2023-325001075-0000	NRHS RADIOLOGY
00716596	C	12/5/2023	Medical	0010	DEP		\$39.19	2023-325001654-0000	PREMIERE PEDIATRICS PLLC
00716597	C	12/5/2023	Medical	0153	EMP		\$99.00	2023-321000445-0000	IMMEDIATE CARE OF
00716598	C	12/5/2023	Medical	0012	DEP		\$75.74	2023-324001126-0000	BLAIR KIRKPATRICK, MD
00716599	C	12/5/2023	Medical	0012	DEP		\$34.89	2023-325000331-0000	NRHS RADIOLOGY
00716600	C	12/5/2023	Medical	WELL	EMP		\$34.59	2023-321000972-0000	MATTISON PATHOLOGY LLP
00716601	C	12/5/2023	Medical	0047	DEP		\$313.32	2023-321001106-0000	MERCY CLINIC OKLAHOMA
00716602	C	12/5/2023	Medical	0027	DEP		\$126.13	2023-321000349-0000	NORMAN REGIONAL ER
00716603	C	12/5/2023	Medical	0076	DEP		\$36.00	2023-321000395-0000	HOLLAND PEDIATRIC
00716604	C	12/5/2023	Medical	0035	DEP		\$58.50	2023-325000895-0000	HOLLAND PEDIATRIC
00716605	C	12/5/2023	Medical	WELL	DEP		\$59.12	2023-325000373-0000	BREAST CARE SPECIALISTS
00716606	C	12/5/2023	Medical	0010	DEP		\$105.95	2023-321001254-0000	OK PAIN PHYS PC PURCELL
00716607	C	12/5/2023	Medical	0153	EMP		\$73.35	2023-324000505-0000	FIRST MED URGENT CARE
00716608	C	12/5/2023	Medical	0333	DEP		\$35.74	2023-324001568-0000	INTEGRIS MEDICAL SUPPLY
00716609	C	12/5/2023	Medical	0010	DEP		\$118.07	2023-325000853-0000	OU HEALTH PARTNERS INC
00716610	C	12/5/2023	Medical	0012	DEP		\$35.05	2023-321000537-0000	RADIOLOGY ASSOCIATES LLC
00716611	C	12/5/2023	Medical	0068	DEP		\$121.43	2023-325001396-0000	SAINTS MEDICAL GROUP LLC
00716612	C	12/5/2023	Medical	0068	DEP		\$109.11	2023-325001397-0000	SAINTS MEDICAL GROUP LLC
00716613	C	12/5/2023	Medical	0005	DEP		\$162.99	2023-325001917-0000	OKLAHOMA CITY

Check Register From History

City of Moore (70009)

City of Moore (79023)

First Fidelity Bank

Reporting From 12/5/2023 Thru 12/5/2023

Check Number	Chk/EFT	Check Date	Type Expenses	CVG TYPE	EMP/DEP	Over Spec	Check Amount	Claim Number	Payee
00716614	C	12/5/2023	Medical	0005	DEP		\$2,260.62	2023-325001918-0000	OKLAHOMA CITY
00716615	C	12/5/2023	Medical	0010	DEP		\$140.91	2023-325001403-0000	SAINTS MEDICAL GROUP LLC
00716616	C	12/5/2023	Medical	0010	EMP		\$120.21	2023-325000975-0000	YAOHAN LAM DERMATOLOGY
00716617	C	12/5/2023	Medical	0005	DEP		\$2,105.65	2023-254002471-0000	LISA WATERMAN DO PC
00716618	C	12/5/2023	Medical	0017	EMP		\$1,766.48	2023-319005437-0000	NR NORMAN LLC
00716619	C	12/5/2023	Medical	0017	EMP		\$1,793.81	2023-319005511-0000	NR NORMAN LLC
00716620	C	12/5/2023	Medical	0017	DEP		\$18.00	2023-324000654-0000	ENABLE PHYSICAL THERAPY
00716621	C	12/5/2023	Medical	0017	EMP		\$1,766.48	2023-324000800-0000	NR NORMAN LLC
00716622	C	12/5/2023	Medical	0017	DEP		\$36.00	2023-326002751-0000	ENABLE PHYSICAL THERAPY
00716623	C	12/5/2023	Medical	0017	DEP		\$36.00	2023-326002752-0000	ENABLE PHYSICAL THERAPY
00716624	C	12/5/2023	Medical	0017	DEP		\$36.00	2023-331005524-0000	ENABLE PHYSICAL THERAPY
00716625	C	12/5/2023	Medical	0017	DEP		\$36.00	2023-331005526-0000	ENABLE PHYSICAL THERAPY
00716626	C	12/5/2023	Medical	0153	DEP		\$78.30	2023-324001707-0000	CLASSEN URGENT CARE
00716627	C	12/5/2023	Medical	0035	EMP		\$73.53	2023-324001230-0000	OHH PHYSICIANS, LLC
00716628	C	12/5/2023	Medical	0073	DEP		\$62.17	2023-321001341-0000	PHYSICIAN MANAGEMENT
00716629	C	12/5/2023	Medical	0177	EMP		\$28.91	2023-321000746-0000	CLINICAL PATHOLOGY LABS
00716630	C	12/5/2023	Medical	0010	EMP		\$136.44	2023-325001016-0000	NORMAN UROLOGY
00716631	C	12/5/2023	Medical	0010	EMP		\$105.89	2023-324001051-0000	MERCY CLINIC OKLAHOMA
00716632	C	12/5/2023	Medical	0010	DEP		\$21.08	2023-324001813-0000	BRANT BENNETT MD PLLC
00716633	C	12/5/2023	Medical	0068	DEP		\$85.15	2023-324000718-0000	FUSION MD
00716634	C	12/5/2023	Medical	0010	EMP		\$145.31	2023-324001788-0000	SPINE SURGERY ASSOCIATES
00716635	C	12/5/2023	Medical	ERHS	EMP		\$2,658.61	2023-290000067-0000	INTEGRIS COMMUNITY HOSP
00716636	C	12/5/2023	Medical	ERHS	EMP		\$2,748.60	2023-310000227-0000	INTEGRIS COMMUNITY HOSP
00716637	C	12/5/2023	Medical	0010	DEP		\$273.56	2023-325001857-0000	OU HEALTH PARTNERS INC
00716638	C	12/5/2023	Medical	0010	DEP		\$97.76	2023-324001448-0000	INTEGRIS MEDICAL GROUP
00716639	C	12/5/2023	Medical	0010	EMP		\$108.05	2023-321000450-0000	NORMAN HEART AND
00716640	C	12/5/2023	Medical	0018	DEP		\$63.00	2023-321001173-0000	JACKSON CHIROPRACTIC
00716641	C	12/5/2023	Medical	ERHS	DEP		\$2,375.11	2023-324000099-0000	INTEGRIS COMMUNITY HOSP
00716642	C	12/5/2023	Medical	0018	EMP		\$4.50	2023-321000378-0000	DELONG FAMILY
00716643	C	12/5/2023	Medical	0010	EMP		\$42.61	2023-324001591-0000	THOMAS D URICE MD LLC
00716644	C	12/5/2023	Medical	0018	EMP		\$9.00	2023-325000475-0000	PROACTIVE CHIROPRACTIC

Check Register From History

City of Moore (70009)

City of Moore (79023)

First Fidelity Bank

Reporting From 12/5/2023 Thru 12/5/2023

Check Number	Chk/EFT	Check Date	Type Expenses	CVG TYPE	EMP/DEP	Over Spec	Check Amount	Claim Number	Payee
00716645	C	12/5/2023	Medical	XRY2	DEP		\$8.97	2023-324001053-0000	MERCY CLINIC OKLAHOMA
00716646	C	12/5/2023	M/N	0020	EMP		\$215.43	2023-325001591-0000	HAVEN COUNSELING CENTER
00716647	C	12/5/2023	Medical	0002	DEP		\$2,120.40	2023-306000118-0000	NORMAN REGIONAL
00716648	C	12/5/2023	Medical	0002	DEP		\$2,120.42	2023-306000119-0000	NORMAN REGIONAL
00716649	C	12/5/2023	Medical	0010	DEP		\$48.91	2023-321000593-0000	SAINTS MEDICAL GROUP LLC
00716650	C	12/5/2023	Medical	0010	DEP		\$46.96	2023-325002017-0000	YAOHAN LAM DERMATOLOGY
00716651	C	12/5/2023	Medical	0004	DEP		\$1,694.52	2023-298000020-0000	INTEGRIS SOUTHWEST
00716652	C	12/5/2023	Medical	0039	EMP		\$123.48	2023-324000387-0000	THE PHYSICIANS GROUP LLC
00716653	C	12/5/2023	Medical	DXL3	DEP		\$110.43	2023-321001247-0000	CLASSEN FAMILY PRACTICE
00716654	C	12/5/2023	Medical	0004	EMP		\$17.03	2023-321000204-0000	OKLAHOMA HEART HOSPITAL
00716655	C	12/5/2023	Medical	0010	DEP		\$38.34	2023-321001108-0000	MERCY CLINIC OKLAHOMA
00716656	C	12/5/2023	Medical	0333	EMP		\$198.26	2023-226001271-0000	MMS OKLAHOMA CITY DBA
00716657	C	12/5/2023	Medical	0010	DEP		\$24.16	2023-326000029-0000	INTEGRIS CARDIOVASCULAR
00716658	C	12/5/2023	Medical	DXL3	DEP		\$83.94	2023-325001716-0000	CLASSEN FAMILY PRACTICE
00716659	C	12/5/2023	Medical	0010	DEP		\$31.04	2023-324001081-0000	NORTHEASTERN OKLAHOMA
00716660	C	12/5/2023	Medical	WELL	DEP		\$99.32	2023-324000385-0000	THE PHYSICIANS GROUP LLC
00716661	C	12/5/2023	Medical	0010	EMP		\$156.17	2023-324001696-0000	TOTAL HEALTHCARE
00716662	C	12/5/2023	Medical	0010	EMP		\$109.22	2023-324000388-0000	THE PHYSICIANS GROUP LLC
00716663	C	12/5/2023	Medical	0153	EMP		\$78.30	2023-321001252-0000	CLASSEN URGENT CARE
00716664	C	12/5/2023	Medical	0153	EMP		\$58.50	2023-324000634-0000	QUICK URGENT CARE
00716665	C	12/5/2023	Medical	0333	EMP		\$51.27	2023-325000486-0000	NORMAN REGIONAL
00716666	C	12/5/2023	Medical	0153	DEP		\$78.30	2023-324001706-0000	CLASSEN URGENT CARE
00716667	C	12/5/2023	Medical	0333	DEP		\$18.70	2023-326002659-0000	VITACARE LLC
00716668	C	12/5/2023	Medical	0333	DEP		\$136.85	2023-326002660-0000	VITACARE LLC
00716669	C	12/5/2023	Medical	ERHS	DEP		\$2,300.00	2023-249000275-0000	NORMAN REGIONAL
00716670	C	12/5/2023	M/N	0020	DEP		\$71.81	2023-325000966-0000	FERGUSON THERAPY
00716671	C	12/5/2023	Medical	0017	EMP		\$36.00	2023-321000910-0000	ORTHOPEDIC SPINE AND
00716672	C	12/5/2023	Medical	0153	DEP		\$78.30	2023-324001184-0000	CLASSEN URGENT CARE
00716673	C	12/5/2023	Medical	0010	DEP		\$65.14	2023-325000252-0000	INTEGRIS MEDICAL GROUP
00716674	C	12/5/2023	Medical	0333	EMP		\$138.82	2023-325000334-0000	DJO LLC
00716675	C	12/5/2023	Medical	WELL	DEP		\$40.44	2023-324001181-0000	ASPEN WOMENS CENTER

Check Register From History

City of Moore (70009)

City of Moore (79023)

First Fidelity Bank

Reporting From 12/5/2023 Thru 12/5/2023

Check Number	Chk/ EFT	Check Date	Type Expenses	CVG TYPE	EMP/ DEP	Over Spec	Check Amount	Claim Number	Payee
00716676	C	12/5/2023	M/N	0020	DEP		\$71.81	2023-325001894-0000	LINDSEY DEAL
00716677	C	12/5/2023	Medical	0010	DEP		\$64.64	2023-321001022-0000	FUSION MD
00716678	C	12/5/2023	Medical	0153	DEP		\$87.00	2023-325001712-0000	CLASSEN URGENT CARE
00716679	C	12/5/2023	Medical	0153	DEP		\$78.30	2023-324001186-0000	CLASSEN URGENT CARE
00716680	C	12/5/2023	Medical	0010	DEP		\$57.01	2023-325002007-0000	NORMAN VISION CLINIC
00716681	C	12/5/2023	Medical	0004	EMP		\$56.61	2023-324001773-0000	OHH PHYSICIANS, LLC
00716682	C	12/5/2023	Medical	0004	EMP		\$17.36	2023-324001780-0000	OHH PHYSICIANS, LLC
00716683	C	12/5/2023	Medical	0004	EMP		\$5.82	2023-324001781-0000	OHH PHYSICIANS, LLC
00716684	C	12/5/2023	Medical	0010	EMP		\$30.85	2023-325001783-0000	OHH PHYSICIANS, LLC
00716685	C	12/5/2023	Medical	0004	EMP		\$60.93	2023-325001784-0000	OHH PHYSICIANS, LLC
00716686	C	12/5/2023	Misc	DIRC	DEP		\$820.00	2023-326000016-0000	ATLAS BILLING COMPANY
00716687	C	12/5/2023	M/N	0020	DEP		\$71.81	2023-324000821-0000	COUNSELING WITH A TWIST
00716688	C	12/5/2023	Medical	0010	DEP		\$55.33	2023-325001647-0000	FUSION MD PLLC
00716689	C	12/5/2023	M/N	0020	EMP		\$89.63	2023-326000105-0000	KEVIN TUTTY
00716690	C	12/5/2023	Medical	0010	EMP		\$72.79	2023-324001581-0000	MERCY CLINIC OKLAHOMA
00716691	C	12/5/2023	Medical	0010	EMP		\$72.79	2023-324001582-0000	MERCY CLINIC OKLAHOMA
00716692	C	12/5/2023	Medical	0010	EMP		\$81.86	2023-324001583-0000	MERCY CLINIC OKLAHOMA
00716693	C	12/5/2023	Medical	0010	EMP		\$81.86	2023-324001584-0000	MERCY CLINIC OKLAHOMA
00716694	C	12/5/2023	M/N	0020	EMP		\$71.81	2023-324000673-0000	COUNSELING WITH A TWIST
00716695	C	12/5/2023	Medical	0010	DEP		\$57.01	2023-321000370-0000	OKLAHOMA ALLERGY AND
00716696	C	12/5/2023	Medical	0080	DEP		\$6.75	2023-321000373-0000	OKLAHOMA ALLERGY AND
00716697	C	12/5/2023	Medical	0018	DEP		\$81.65	2023-319000328-0000	BODIN CHIROPRACTIC PLLC
00716698	C	12/5/2023	Medical	0010	DEP		\$121.44	2023-325000563-0000	SAINTS MEDICAL GROUP LLC
00716699	C	12/5/2023	Medical	WELL	EMP		\$118.15	2023-321000589-0000	SAINTS MEDICAL GROUP LLC
00716700	C	12/5/2023	Medical	0153	EMP		\$78.30	2023-324001710-0000	CLASSEN URGENT CARE
00716701	C	12/5/2023	Medical	0004	EMP		\$2,043.09	2023-254001267-0000	OKLAHOMA CENTER FOR
00716702	C	12/5/2023	Medical	0076	DEP		\$36.00	2023-321000393-0000	HOLLAND PEDIATRIC
00716703	C	12/5/2023	Medical	0076	DEP		\$36.00	2023-325000896-0000	HOLLAND PEDIATRIC
00716704	C	12/5/2023	Medical	0177	DEP		\$5.15	2023-324001337-0000	LABORATORY CORPORATION
00716705	C	12/5/2023	Medical	0010	DEP		\$252.01	2023-325001313-0000	HEALTHCARE EXPRESS LLP
00716706	C	12/5/2023	Medical	0080	DEP		\$69.57	2023-321000371-0000	OKLAHOMA ALLERGY AND

Check Register From History

City of Moore (70009)

City of Moore (79023)

First Fidelity Bank

Reporting From 12/5/2023 Thru 12/5/2023

Check Number	Chk/ EFT	Check Date	Type Expenses	CVG TYPE	EMP/ DEP	Over Spec	Check Amount	Claim Number	Payee
00716707	C	12/5/2023	Medical	0080	DEP		\$127.87	2023-325001068-0000	OKLAHOMA ALLERGY AND
00716708	C	12/5/2023	M/N	0020	EMP		\$71.81	2023-321000979-0000	COUNSELING WITH A TWIST
00716709	C	12/5/2023	Medical	0010	EMP		\$215.10	2023-325001446-0000	OKLAHOMA
00716710	C	12/5/2023	Medical	0010	EMP		\$40.50	2023-321001167-0000	MOYER CHIROPRACTIC, INC.
00716711	C	12/5/2023	Medical	0010	EMP		\$71.92	2023-324000427-0000	KIDNEY SPECIALISTS OF
00716712	C	12/5/2023	Medical	0011	EMP		\$238.68	2023-324001668-0000	ANESTHESIA SPECIALISTS OF
00716713	C	12/5/2023	Medical	0177	EMP		\$43.10	2023-325000911-0000	DIAGNOSTIC LABORATORY
00716714	C	12/5/2023	Medical	0010	EMP		\$81.00	2023-325001582-0000	MOYER CHIROPRACTIC, INC.
00716715	C	12/5/2023	Medical	0039	DEP		\$134.71	2023-324001860-0000	OKLAHOMA CITY
00716716	C	12/5/2023	Medical	0004	DEP		\$126.00	2023-325000108-0000	LAKESIDE WOMEN'S CENTER
00716717	C	12/5/2023	Medical	0011	DEP		\$146.25	2023-325002029-0000	HPI PHYSICIANS LLC
00716718	C	12/5/2023	Medical	0011	DEP		\$146.25	2023-325002030-0000	HPI PHYSICIANS LLC
00716719	C	12/5/2023	Medical	LAB2	DEP		\$4.03	2023-325001920-0000	ROBERT REYNOLDS MD PC
00716720	C	12/5/2023	Medical	LAB3	EMP		\$451.53	2023-321000312-0000	FOREFRONT DERMATOLOGY
00716721	C	12/5/2023	Medical	0066	EMP		\$279.61	2023-278000144-0000	COMMUNITY HOSPITAL
00716722	C	12/5/2023	Medical	0017	EMP		\$36.00	2023-321000654-0000	YUKON WOUND CARE REHAB
00716723	C	12/5/2023	Medical	0010	EMP		\$46.04	2023-324001056-0000	NEUROSURGICAL AND SPINE
00716724	C	12/5/2023	Medical	0010	EMP		\$46.04	2023-325001554-0000	NEUROSURGICAL AND SPINE
00716725	C	12/5/2023	Medical	0076	DEP		\$36.00	2023-321000966-0000	ALEXANDRA ROY
00716726	C	12/5/2023	Medical	0153	DEP		\$51.04	2023-321000817-0000	MEDICAL RESOURCE
00716727	C	12/5/2023	Medical	WELL	EMP		\$115.65	2023-321000277-0000	PRIMARY CARE SOUTH OKC
00716728	C	12/5/2023	Medical	0010	EMP		\$81.59	2023-324000446-0000	PRIMARY CARE SOUTH OKC
00716729	C	12/5/2023	Medical	DXL3	DEP		\$701.48	2023-324001578-0000	MERCY CLINIC OKLAHOMA
00716730	C	12/5/2023	Medical	0010	DEP		\$46.74	2023-325002052-0000	THE PHYSICIANS GROUP LLC
00716731	C	12/5/2023	Medical	0153	DEP		\$48.67	2023-324000671-0000	QUICK URGENT CARE
00716732	C	12/5/2023	Medical	0010	DEP		\$34.04	2023-325001858-0000	OU HEALTH PARTNERS INC
00716733	C	12/5/2023	Medical	0153	DEP		\$78.30	2023-324001190-0000	CLASSEN URGENT CARE
00716734	C	12/5/2023	Medical	WELL	DEP		\$59.12	2023-325000367-0000	BREAST CARE SPECIALISTS
00716735	C	12/5/2023	Medical	0010	EMP		\$49.56	2023-321001144-0000	BLAIR KIRKPATRICK, MD
00716736	C	12/5/2023	Medical	0010	DEP		\$126.85	2023-325001417-0000	JOEL C RAZOOK MD
00716737	C	12/5/2023	Medical	0177	EMP		\$18.48	2023-325005170-0000	DIAGNOSTIC LABORATORY

Check Register From History

City of Moore (70009)

City of Moore (79023)

First Fidelity Bank

Reporting From 12/5/2023 Thru 12/5/2023

Check Number	Chk/EFT	Check Date	Type Expenses	CVG TYPE	EMP/DEP	Over Spec	Check Amount	Claim Number	Payee
00716738	C	12/5/2023	Medical	0021	EMP		\$180.81	2023-326002422-0000	TARIQ MAHMOOD
00716739	C	12/5/2023	Medical	WELL	DEP		\$118.15	2023-321000588-0000	SAINTS MEDICAL GROUP LLC
00716740	C	12/5/2023	Medical	0153	DEP		\$106.14	2023-325001815-0000	MEDICAL RESOURCE
00716741	C	12/5/2023	Medical	SUR3	EMP		\$123.28	2023-324000445-0000	INSPIRE WELLNESS CLINIC &
190 Checks Paid: \$53,073.74 ✓							Electronic Payments: \$0.00		0 Total Adjustments: \$0.00
190 Payments: \$53,073.74									
Reserve Income:				\$0.00					



Check Register

City of Moore

Method Desc	Check Date	Claim # Claimant Name	Payee Payment Type	Service From Service To	Run ID	Amount	Check #
Check	11/30/2023	2050001005	Boyce, Vernon Temporary Total Disability	11/26/2023 12/02/2023	138925	\$953.18	307472
	11/30/2023	022050000202	HEALTHESYSTEMS Drug Coverage	11/21/2023 11/21/2023	138927	\$29.08	307473
	11/30/2023	Combined Combined	COMPCHOICE LLC Medical	11/07/2023 11/17/2023	138927	\$1,481.23	307474
	11/30/2023	2050001175	Two Oaks Investments, LLC Fees including PI, IOS, background checks, EDI fees	11/23/2023 11/23/2023	138927	\$2.00	307475
	11/30/2023	2050000404	Total Hearing, Inc Medical	11/27/2023 11/27/2023	138927	\$68.74	307476
Total By - Method Desc: 5					Total for Method		
Total Number of Checks: 7					Desc:	\$2,534.23	\$2,534.23
					Total Amount:	\$2,534.23	\$2,534.23



Check Register

City of Moore

Method Desc	Check Date	Claim # Claimant Name	Payee Payment Type	Service From Service To	Run ID	Amount	Check #
Check	12/07/2023	2050001005	Boyce, Vernon Temporary Total Disability	12/03/2023 12/09/2023	139094	\$953.18	307478
	12/07/2023	Combined Combined	MCBRIDE ORTHOPEDIC HOSPITAL, LLC Physician	11/20/2023 11/20/2023	139096	\$213.32	307479
	12/07/2023	Combined Combined	HEALTHESYSTEMS Drug Coverage	11/28/2023 11/28/2023	139096	\$36.56	307480
	12/07/2023	2050001175	CLASSEN URGENT CARE CLINIC, LLC Physician	11/16/2023 11/16/2023	139096	\$127.50	307481
	12/07/2023	022050000008	NGA Anesthesia, PLLC Medical	08/10/2023 08/10/2023	139096	\$194.40	307482
	12/07/2023	Combined Combined	RISING MEDICAL SOLUTIONS, LLC Bill Review Fees	11/20/2023 11/20/2023	139096	\$44.32	307483
Total By - Method Desc: 6					Total for Method		
Total Number of Checks: 8					Desc:	\$1,569.28	\$1,569.28 ✓
					Total Amount:	\$1,569.28	\$1,569.28



Check Register

City of Moore

Method Desc	Check Date	Claim # Claimant Name	Payee Payment Type	Service From Service To	Run ID	Amount	Check #
Check	12/04/2023	Compton, Christina 2050001179	Compton, Christina Property Damage	11/30/2023 11/30/2023	139013	\$359.70	307477
Total By - Method Desc: 1				Total for Method			
Total Number of Checks: 1				Desc:		\$359.70	\$359.70
				Total Amount:		\$359.70	\$359.70

Agenda Item Number 12 being:

CONSENT DOCKET:

- A) RECEIVE AND APPROVE THE MINUTES OF THE REGULAR MOORE RISK MANAGEMENT MEETING HELD NOVEMBER 6, 2023
- B) APPROVE AND RATIFY CLAIMS AND EXPENDITURES FOR FY 2023-2024 IN THE AMOUNT OF \$74,384.94.

Trustee Williams moved to approve the consent docket in its entirety, second by Trustee Blair. Motion carried unanimously.

Ayes: Griffith, Blair, Williams, Webb, Hunt
Nays: None
Absent: Lewis

THE MOORE RISK MANAGEMENT MEETING WAS RECESSED AND THE MOORE ECONOMIC DEVELOPMENT AUTHORITY MEETING WAS CONVENED AT 6:47 P.M.

Agenda Item Number 13 being:

ROLL CALL

PRESENT: Griffith, Blair, Williams, Webb, Hunt
ABSENT: Lewis

Agenda Item Number 14 being:

CONSENT DOCKET:

- A) RECEIVE AND APPROVE THE MINUTES OF THE REGULAR MOORE ECONOMIC DEVELOPMENT AUTHORITY MEETING HELD OCTOBER 16, 2023.

Trustee Williams moved to approve the consent docket in its entirety, second by Trustee Griffith. Motion carried unanimously.

Ayes: Griffith, Blair, Williams, Webb, Hunt
Nays: None
Absent: Lewis

Agenda Item Number 15 being:

CONSIDER, AND IF DEEMED APPROPRIATE, ELECT KATHY GRIFFITH AS VICE-CHAIR OF THE MOORE ECONOMIC DEVELOPMENT AUTHORITY.

Trustee Williams moved to elect Kathy Griffith as Vice-Chair of the Moore Economic Development Authority, second by Trustee Webb. Motion carried unanimously.

Ayes: Griffith, Blair, Williams, Webb, Hunt
Nays: None
Absent: Lewis

THE MOORE ECONOMIC DEVELOPMENT AUTHORITY MEETING WAS RECESSED AND THE CITY COUNCIL MEETING RECONVENED WITH VICE-MAYOR MELISSA HUNT PRESIDING AT 6:48 P.M.

Agenda Item Number 16 being:

NEW BUSINESS:

A) CITIZENS' FORUM FOR ITEMS NOT ON THE AGENDA.

There were no citizens to speak.

B) ITEMS FROM THE CITY COUNCIL/MPWA TRUSTEES.

There were no items from the City Council/Trustees.

C) ITEMS FROM THE CITY/TRUST MANAGER.

Brooks Mitchell, City Manager, advised that the Christmas light show at The Station will be held from November 20, 2023 until January 1, 2024 from 6:00 p.m. to 10:00 p.m. Mr. Mitchell also thanked the voters for passage of the GO Bond election held November 14, 2023.

Agenda Item Number 17 being:

ADJOURNMENT

Councilman Blair moved to adjourn the City Council meeting, second by Councilman Williams. Motion carried unanimously.

Ayes: Griffith, Blair, Williams, Webb, Hunt
Nays: None
Absent: Lewis

The City Council, Moore Public Works Authority, Moore Risk Management, and Moore Economic Development Authority meetings were adjourned at 6:49 p.m.

TRANSCRIBED BY:

RHONDA BAXTER, Executive Assistant

FOR:

KATHY GRIFFITH, MPWA Secretary